

DL7440/DL7480
Digital Oscilloscope

U S E R ' S M A N U A L

Product Registration

Thank you for purchasing YOKOGAWA products.

YOKOGAWA provides registered users with a variety of information and services. Please allow us to serve you best by completing the product registration form accessible from our homepage.

<http://www.yokogawa.com/tm/>

Thank you for purchasing the DL7400 (DL7440/DL7480) Digital Oscilloscope. This user's manual contains useful information about the instrument's functions and operating procedures and lists the handling precautions of the DL7400. To ensure correct use, please read this manual thoroughly before beginning operation. Keep this manual in a safe place for quick reference in the event a question arises.

The following manuals are provided for the DL7400.

Manual Title	Manual No.	Description
DL7440/DL7480 User's Manual	IM 701450-01E	This manual. Explains all functions and procedures of the DL7440/DL7480 excluding the communication functions.
DL7440/DL7480 Operation Guide	IM 701450-02E	Provides a brief explanation of the functions and basic operating procedures of the DL7440/DL7480.
DL7440/DL7480 Communication Interface User's Manual (CD-ROM)	IM 701450-17E	Describes the communication functions of the communication interface.

Notes

- The contents of this manual are subject to change without prior notice as a result of continuing improvements to the instrument's performance and functions. The figures given in this manual may differ from those that actually appear on your screen.
- Every effort has been made in the preparation of this manual to ensure the accuracy of its contents. However, should you have any questions or find any errors, please contact your nearest YOKOGAWA dealer.
- Copying or reproducing all or any part of the contents of this manual without the permission of Yokogawa Electric Corporation is strictly prohibited.
- The TCP/IP software of this product and the document concerning the TCP/IP software have been developed/created by YOKOGAWA based on the BSD Networking Software, Release 1 that has been licensed from California University.

Trademarks

- Microsoft, Internet Explorer, MS-DOS, Windows, Windows NT, and Windows XP are either registered trademarks or trademarks of Microsoft Corporation in the United States and/or other countries.
- Adobe, Acrobat, and PostScript are trademarks of Adobe Systems Incorporated.
- Zip is either a registered trademark or trademark of Iomega Corporation in the United States and/or other countries.
- UNIX is either a registered trademark or trademark of The Open Group in the United States and/or other countries.
- For purposes of this manual, the TM and ® symbols do not accompany their respective trademark names or registered trademark names.
- Other company and product names are trademarks or registered trademarks of their respective companies.

Revisions

- 1st Edition: February 2003
- 2nd Edition: November 2003
- 3rd Edition: February 2004
- 4th Edition: April 2005

Checking the Contents of the Package

Unpack the box and check the contents before operating the instrument. If some of the contents are not correct, or if any items are missing or damaged, contact the dealer from whom you purchased them.

DL7440/DL7480

Check that the model name and suffix code given on the name plate on the rear panel match those on the order.

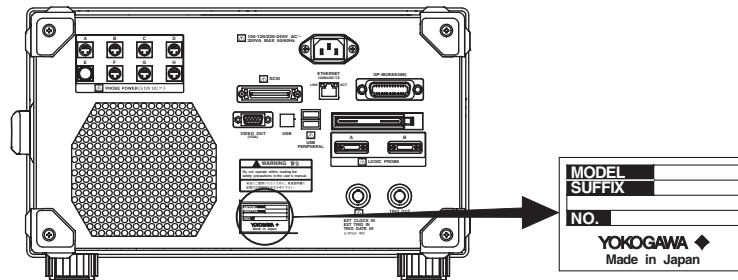

Model and Suffix Codes

Model	Suffix	Specifications
701450 (DL7440)		4-channel, 4 MW memory model
701460 (DL7440)		4-channel, 16 MW memory model
701470 (DL7480)		8-channel, 4 MW memory model
701480 (DL7480)		8-channel, 16 MW memory model
Power cord	-D	UL/CSA Standard power cord (Part No.: A1006WD)
	-F	[Maximum rated voltage: 125 V; Maximum rated current: 7 A] VDE Standard Power Cord (Part No.: A1009WD) [Maximum rated voltage: 250 V; Maximum rated current: 10 A]
	-Q	BS Standard Power Cord (Part No.: A1054WD) [Maximum rated voltage: 250 V; Maximum rated current: 10 A]
	-R	AS Standard Power Cord (Part No.: A1024WD) [Maximum rated voltage: 250 V; Maximum rated current: 10 A]
	-H	GB Standard Power Cord (complies with the CCC)(Part No.: A1064WD) [Maximum rated voltage: 250 V, Maximum rated current: 10 A]
Built-in storage media drive	-J1	Floppy disk drive
	-J2	Zip drive
(Select either drive for the built-in storage media drive at the time of purchase)		
Options	/B5	Built-in printer ¹
	/E4	4 additional 700988 passive probes ^{2,6,7} (option only for the DL7480)
	/EX4	4 additional 701941 miniature passive probes in place of 700988 passive probes ⁶
	/EA4	4 additional 701941 miniature passive probes ⁷ (option only for the DL7480)
	/P4	4 additional probe power supply terminals ³ (option only for the DL7480)
	/N3	Logic input for the 4 MW memory model
	/N4	Logic input for the 16 MW memory model
	/C7	SCSI
	/C10	Ethernet interface
	/G2	User-defined computation
/G4	Power supply analysis function ⁴ (includes user-defined computation)	
/F5	I ² C + SPI bus analysis ⁵	
/F7	CAN + SPI bus analysis ⁵	
/F8	I ² C + CAN + SPI bus analysis ⁵	

1 1 roll paper (B9850NX) is included.

2 The DL7480 comes standard with four 700988 passive probes.

3 The DL7480 comes standard with 4 probe power supply terminals.

4 The /G4 option contains the user-defined computation function. Therefore, it cannot be specified simultaneously with the /G2 option.

5 /F5, /F7, and /F8 options cannot be specified simultaneously.

6 /E4 and /EX4 options cannot be specified simultaneously.

7 /E4 and /EA4 options cannot be specified simultaneously.

NO. (Instrument Number)

When contacting the dealer from which you purchased the instrument, please give them the instrument number.

Standard Accessories

The standard accessories below are supplied with the instrument.

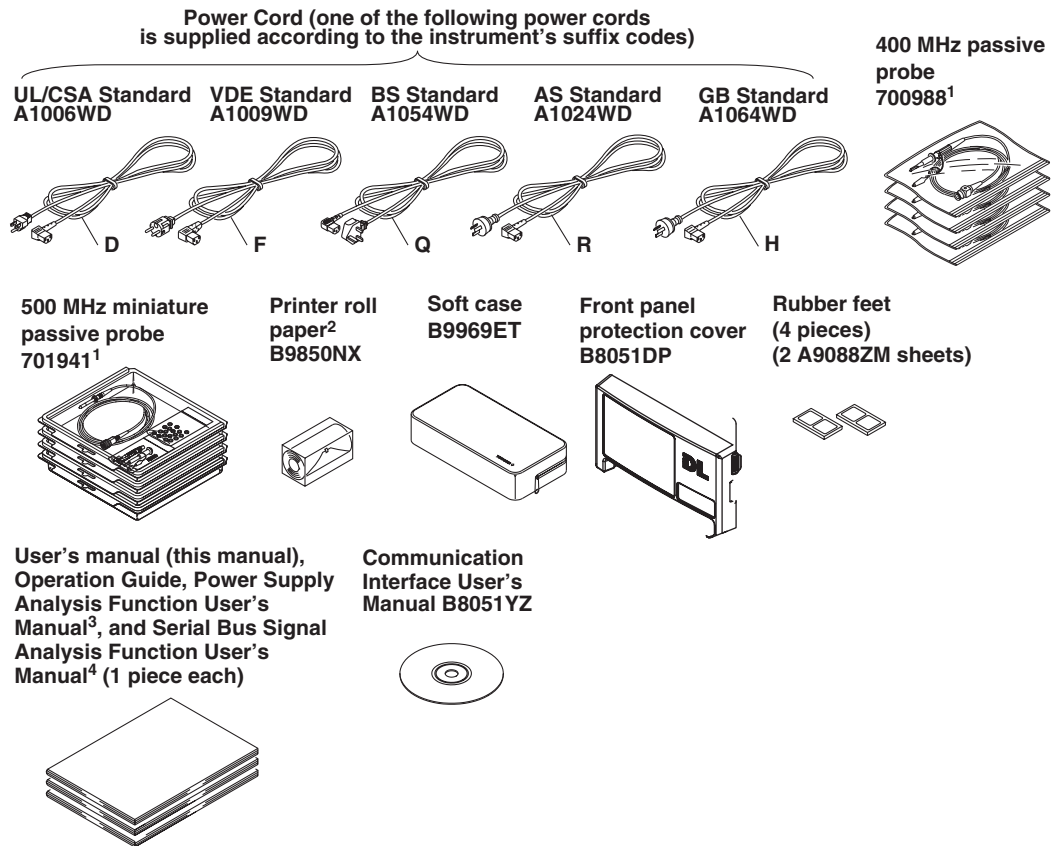

1 On models with the /EX4 option, 701941 passive probes are provided in place of 700988 passive probes.
 2 Provided on models with the /B5 option (built-in printer).
 3 Provided on models with the /G4 option (power supply analysis function).
 4 Provided on models with the /F5, /F7, or /F8 option (bus analysis function).

Optional Accessories (Sold Separately)

The optional accessories below are available for purchase separately.

FET probe
700939

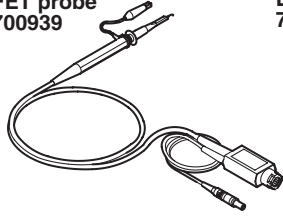

Logic probe
701980/701981

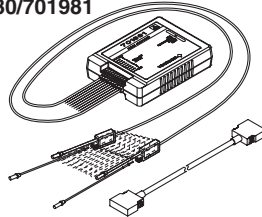

100:1 probe
700978

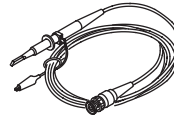

Miniature passive probe
701941

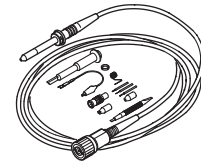

Differential probe
700924/701921*

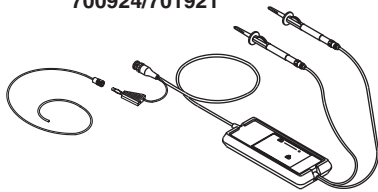

Differential probe
700925

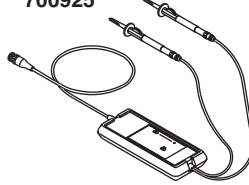

Probe power supply cable
(for the 700924 and 700925)
B9852MJ

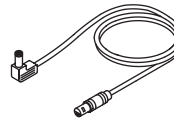

Differential probe
701920

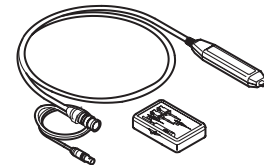

* The 701921 comes with a probe power cable (model B9852MJ).

Differential probe
701922

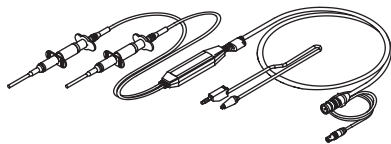

Current probe
700937/701932/701933

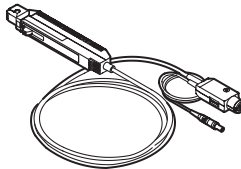

Current probe
701930/701931

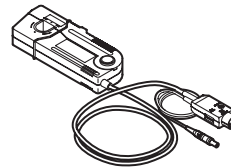

Mini clip converter
B9852CR

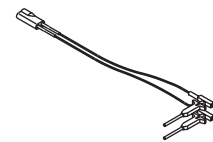

Earth lead
B9852CT

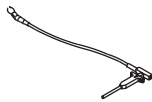

IC clip
B9852ES



Spare Parts (Sold Separately)

The spare parts below are available for purchase separately.

Part Name	Model/Part Number	Minimum Q'ty	Remarks
Printer roll paper	B9850NX	5	Thermalsensible paper, total length of 30 m
400 MHz passive probe	700988	1	Input resistance of 10 MΩ and overall length of 1.5 m

Safety Precautions

This instrument is an IEC safety class I instrument (provided with terminal for protective earth grounding). The general safety precautions described herein must be observed during all phases of operation. If the instrument is used in a manner not specified in this manual, the protection provided by the instrument may be impaired. Yokogawa Electric Corporation assumes no liability for the customer's failure to comply with these requirements.

The following symbols are used on this instrument.



Danger. Refer to the user's manual.

This symbol appears on dangerous locations on the instrument which require special instructions for proper handling or use. The same symbol appears in the corresponding place in the manual to identify those instructions.



Functional ground terminal (do not use this terminal as a protective ground terminal.)



Alternating current



Direct current



ON (power)



OFF (power)



ON (power)



OFF (power)

Make sure to comply with the precautions below. Not complying might result in injury or death.



WARNING

- **Use the Correct Power Supply**
Before connecting the power cord, ensure that the source voltage matches the rated supply voltage of the instrument and that it is within the maximum rated voltage of the provided power cord.
 - **Use the Correct Power Cord and Plug**
To prevent the possibility of electric shock or fire, be sure to use the power cord supplied by YOKOGAWA. The main power plug must be plugged into an outlet with a protective earth terminal. Do not disable this protection by using an extension cord without protective earth grounding.
 - **Connect the Protective Grounding Terminal**
Make sure to connect the protective earth to prevent electric shock before turning ON the power. The power cord that comes with the instrument is a three-prong type power cord. Connect the power cord to a properly grounded three-prong outlet.
 - **Do Not Impair the Protective Grounding**
Never cut off the internal or external protective earth wire or disconnect the wiring of the protective earth terminal. Doing so poses a potential shock hazard.
 - **Do Not Operate with Defective Protective Grounding or Fuse**
Do not operate the instrument if the protective earth or fuse might be defective. Make sure to check them before operation.
 - **Do Not Operate in an Explosive Atmosphere**
Do not operate the instrument in the presence of flammable liquids or vapors. Operation in such environments constitutes a safety hazard.
 - **Do Not Remove Covers**
The covers should be removed by YOKOGAWA's qualified personnel only. Opening the cover is dangerous, because some areas inside the instrument have high voltages.
 - **Ground the Instrument before Making External Connections**
Securely connect the protective grounding before connecting to the item under measurement or an external control unit. If you are going to touch the circuit, make sure to turn OFF the circuit and check that no voltage is present.
To prevent the possibility of electric shock or an accident, connect the ground of the probe and input connector to the ground of the item being measured.
-

Conventions Used in This Manual

Safety Markings

The following markings are used in this manual.



Improper handling or use can lead to injury to the user or damage to the instrument. This symbol appears on the instrument to indicate that the user must refer to the user's manual for special instructions. The same symbol appears in the corresponding place in the user's manual to identify those instructions. In the manual, the symbol is used in conjunction with the word "WARNING" or "CAUTION."

WARNING

Calls attention to actions or conditions that could cause serious injury or death to the user, and precautions that can be taken to prevent such occurrences.

CAUTION

Calls attentions to actions or conditions that could cause light injury to the user or damage to the instrument or user's data, and precautions that can be taken to prevent such occurrences.

Note

Calls attention to information that is important for proper operation of the instrument.

Notations Used on Pages Describing Operating Procedures

On pages that describe the operating procedures in Chapter 3 through 16, the following notations are used to distinguish the procedures from their explanations.

Procedure

This subsection contains the operating procedure used to carry out the function described in the current chapter. All procedures are written with inexperienced users in mind; experienced users may not need to carry out all the steps.

Explanation

This subsection describes the setup parameters and the limitations on the procedures. It may not give a detailed explanation of the function. For a detailed explanation of the function, see chapter 2.

Notations Used in the Procedures

Panel Keys and Soft keys

Bold characters used in the procedural explanations indicate characters that are marked on the panel keys or the characters of the soft keys displayed on the screen menu.

SHIFT+Panel Key

SHIFT+key means you will press the SHIFT key to turn ON the green indicator that is located above the SHIFT key and then press the panel key. The setup menu marked in purple above the panel key that you pressed appears on the screen.

Jog Shuttle & SELECT

Jog shuttle & SELECT indicates selecting or setting parameters and entering values using the jog shuttle, the SELECT key, and other keys. For details on the procedure, see section 4.1 or 4.2.

Unit

k: Denotes "1000." Example: 100 kS/s

K: Denotes "1024." Example: 459 KB (file data size)

Flow of Operation

The figure below is provided to familiarize the first-time user with the general flow of the DL7400 operation. For a description of each item, see the relevant section or chapter.

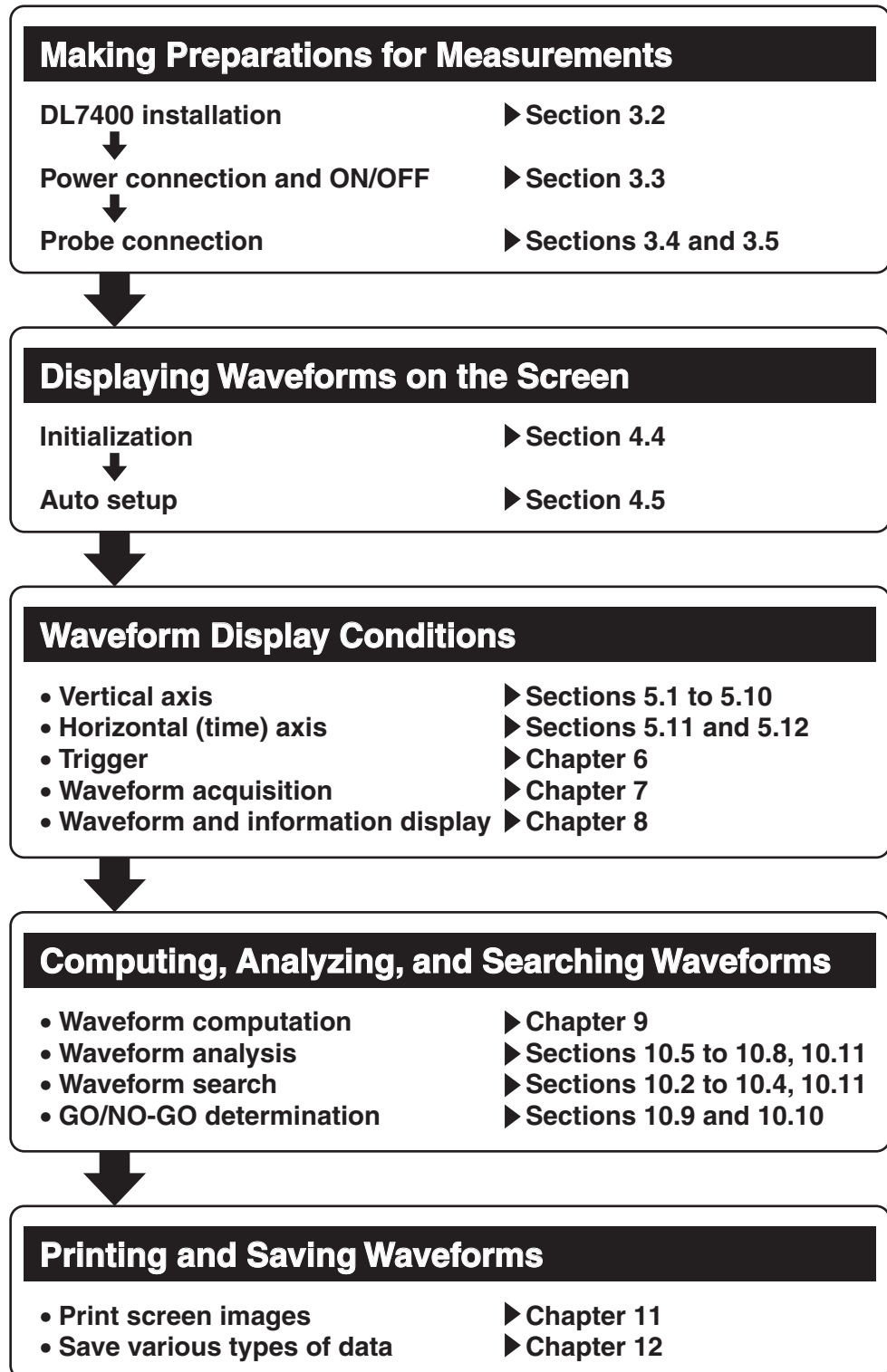

Contents

Checking the Contents of the Package	ii
Safety Precautions	v
Conventions Used in This Manual	vii
Flow of Operation	viii
Chapter 1 Names and Functions of Parts	
1.1 Front Panel, Rear Panel, and Top Panel	1-1
1.2 Panel Keys and Knobs	1-3
1.3 Display	1-6
Chapter 2 Explanation of Functions	
2.1 System Configuration and Block Diagram	2-1
System Configuration,Block Diagram	
2.2 Vertical and Horizontal Axes	2-2
Vertical Sensitivity,Vertical Position of the Waveform ,Input Coupling, Probe Attenuation/Current-to-Voltage Conversion Ratio,Offset Voltage, Bandwidth Limit,Linear Scaling,Logic Signal Input (Optional),Horizontal Axis (Time Axis)	
2.3 Trigger	2-8
Trigger Source, Trigger Slope, and Trigger Level,Trigger Type,Trigger Mode,Trigger Position, Trigger Delay,Trigger Coupling,HF Rejection,Trigger Hysteresis , Trigger Hold Off,Action-on-Trigger,Trigger Gate	
2.4 Waveform Acquisition and Display Conditions	2-15
Record Length,Interleave Mode,Sampling Mode,Acquisition Mode,Sequential Store, History Memory,Display Format,Display Interpolation,Accumulated Display, Zooming the Waveform,X-Y Waveform Display,Snapshot and Clear Trace , Setting Other Waveform Display Items (Graticule, Scale Value, Waveform Label, and Translucent)	
2.5 Waveform Computation	2-21
Addition, Subtraction, and Multiplication,Binary Computation,Inversion, Differentiation and Integration,Phase Shift,Scaling the Computed Waveform, Power Spectrum Computation,User-Defined Computation (Optional)	
2.6 Analyzing and Searching Waveforms	2-25
Displaying History Waveforms,History Search,Search & Zoom,Cursor Measurements, Automated Measurement of Waveform Parameters,GO/NO-GO Determination	
2.7 Communication	2-32
Communication Using Commands (GP-IB, USB, or Ethernet), Saving and Loading Data from a Network Drive (FTP Client), Printing on a Network Printer (LPR Client),Transmitting E-Mails, Accessing the DL7400 from a PC or Workstation (FTP Server),Web Server	
2.8 Other Useful Functions	2-34
Entering Values and Text Using the USB Keyboard,Operating the DL7400 Using a USB Mouse, Initialization,Auto Setup,Preset,Printing Screen Images, Saving and Loading Data from the Storage Medium, Operating the DL7400 Using a Free Software Program	
Chapter 3 Making Preparations for Measurements	
3.1 Handling Precautions	3-1
△ 3.2 Installing the Instrument	3-3
△ 3.3 Connecting the Power Supply and Turning ON/OFF the Power Switch	3-5
△ 3.4 Connecting the Probe	3-7
△ 3.5 Compensating the Probe (Phase Correction)	3-10
△ 3.6 Connecting Logic Probes (Optional)	3-11
3.7 Setting the Date and Time	3-13

Chapter 4 Common Operations

4.1 Operations and Functions of Keys and the Jog Shuttle 4-1

4.2 Entering Values and Strings 4-3

4.3 Operating the DL7400 Using a USB Keyboard or a USB Mouse 4-6

4.4 Initializing Settings 4-14

4.5 Performing Auto Setup 4-16

4.6 Performing Calibration 4-19

4.7 Correcting the Delay Time of the Input Signals 4-21

4.8 Using the Help Function 4-23

Chapter 5 Vertical and Horizontal Axes

5.1 Turning Channels ON/OFF 5-1

5.2 Setting V/div 5-2

5.3 Setting the Vertical Position of the Waveform 5-4

△ 5.4 Setting the Input Coupling 5-6

5.5 Selecting the Probe Attenuation/Current-to-Voltage Conversion Ratio 5-8

5.6 Setting the Offset Voltage 5-9

5.7 Using the Preset Function 5-11

5.8 Setting Bandwidth Limits 5-14

5.9 Using the Linear Scaling Function 5-15

5.10 Turning ON/OFF the Logic Input and Setting the Threshold Level 5-17

△ 5.11 Selecting the Time Base 5-20

5.12 Setting T/div 5-22

Chapter 6 Triggers

6.1 Selecting the Trigger Mode 6-1

6.2 Setting the Trigger Position 6-3

6.3 Setting the Trigger Delay 6-5

6.4 Setting the Hold Off Time 6-6

6.5 Setting the Edge Trigger (SIMPLE) 6-9

6.6 Setting the External Trigger (SIMPLE) 6-12

6.7 Activating Triggers on the Commercial Power Supply (SIMPLE) 6-14

6.8 Setting the A->B(N) Trigger (ENHANCED) 6-15

6.9 Setting the A Delay B Trigger (ENHANCED) 6-18

6.10 Setting the Pattern Trigger (ENHANCED) 6-21

6.11 Setting the Width (Pulse<Time, Pulse>Time, T1<Pulse<T2, and Time Out) Trigger (ENHANCED) 6-25

6.12 Setting the OR Trigger (ENHANCED) 6-30

6.13 Setting the Window Trigger (ENHANCED) 6-33

6.14 Setting the TV Trigger (ENHANCED) 6-36

6.15 Setting the Logic Trigger (ENHANCED, Optional) 6-41

6.16 Setting the Action-on-Trigger 6-44

△ 6.17 Setting the Trigger Gate 6-46

Chapter 7 Waveform Acquisition

7.1 Starting/Stopping Waveform Acquisition 7-1

7.2 Setting the Record Length 7-2

7.3 Using Interleave Mode 7-3

7.4 Turning ON/OFF Repetitive Sampling Mode 7-4

7.5 Setting the Acquisition Mode 7-6

7.6 Performing Sequential Store (SINGLE(N) Mode) 7-10

Chapter 8 Waveform Display and Information Display

8.1 Setting the Display Format 8-1

8.2 Performing Display Interpolation 8-4

8.3 Accumulating Waveforms 8-6

8.4 Zooming the Waveform 8-8

8.5 Displaying X-Y Waveforms 8-12

8.6 Taking Snapshots and Clearing Traces 8-15

8.7 Changing the Graticule 8-16

8.8 Turning ON/OFF the Scale Display 8-17

8.9 Setting Waveform Labels and Turning ON/OFF the Display 8-18

8.10 Turning ON/OFF the Translucent Display 8-20

Chapter 9 Waveform Computation

9.1 Entering Normal Computation Mode, Displaying Computed Waveforms, and Assigning Labels to Computed Waveforms 9-1

9.2 Adding, Subtracting, and Multiplying Waveforms 9-3

9.3 Performing Binary Computation 9-6

9.4 Inverting Waveforms 9-8

9.5 Differentiating and Integrating Waveforms 9-10

9.6 Performing Power Spectrum Computation (FFT) 9-12

9.7 Smoothing Waveforms 9-15

9.8 Shifting the Phase 9-17

9.9 Performing User-Defined Computation (Optional) 9-19

Chapter 10 Analyzing and Searching Waveforms

10.1 Displaying History Waveforms 10-1

10.2 Searching the History Waveforms Using Zones (History Search) 10-5

10.3 Searching History Waveforms Using Waveform Parameters (History Search) 10-10

10.4 Searching Waveforms Using the Search and Zoom Function 10-15

10.5 Making Cursor Measurements 10-33

10.6 Automated Measurement of Waveform Parameters 10-46

10.7 Performing Statistical Processing of the Measured Values of Waveform Parameters 10-54

10.8 Performing Automated Measurements of Waveform Parameters on Dual Areas 10-61

10.9 Performing GO/NO-GO Determination Using Zones 10-66

10.10 Performing GO/NO-GO Determination Using Measured Waveform Parameters 10-72

10.11 Analyzing and Searching SPI Signals 10-76

Chapter 11 Printing Screen Images

11.1 Installing the Roll Paper into the Built-in Printer (Optional) 11-1

11.2 Printing Using the Built-in Printer (Optional) 11-3

11.3 Printing Using a USB Printer 11-6

11.4 Printing Using a Network Printer (Optional) 11-11



Chapter 12 Saving and Loading Data

12.1	Storing and Recalling Setup Data	12-1
12.2	Floppy Disk, Zip Disk, and PC Cards	12-3
12.3	Connecting MO Disk Drives or Hard Disks to the SCSI	12-7
12.4	Changing the SCSI ID Number	12-8
12.5	Connecting USB Storage to the USB PERIPHERAL Interface	12-9
12.6	Formatting the Storage Medium	12-10
12.7	Saving/Loading the Setup Data	12-15
12.8	Saving/Loading the Waveform Data	12-20
12.9	Saving/Loading the Snapshot Waveforms	12-28
12.10	Saving the Results of the Automated Measurement of Waveform Parameters	12-31
12.11	Saving the Detailed Analysis List of SPI Signals	12-33
12.12	Saving Screen Image Data	12-35
12.13	Displaying Thumbnails of the Saved Screen Image Data	12-39
12.14	Changing the File Attributes and Deleting Files	12-43
12.15	Copying Files	12-47
12.16	Changing the Directory or File Name of the Storage Medium and Creating Directories	12-50

Chapter 13 Ethernet Communications (Optional)

13.1	Connecting the DL7400 to the Network	13-1
13.2	Setting Up TCP/IP	13-3
13.3	Saving and Loading Waveform/Setup/Image Data on a Network Drive (FTP Client Function)	13-8
13.4	Entering Settings for Printing Screen Images on the Network Printer (LPR Client Function)	13-11
13.5	Sending Periodic or Action Mail (SMTP Client Function)	13-12
13.6	Accessing the DL7400 from a PC or Workstation (FTP Server Function)	13-16
13.7	Using the Web Server Function	13-18
13.8	Setting the Time Difference from GMT (Greenwich Mean Time)	13-41
13.9	Checking the Presence of the Ethernet Interface (Optional) and the MAC Address ...	13-43
13.10	Setting the FTP Passive Mode and LPR/SMTP Timeout	13-44
13.11	Using the Storage Medium as a Windows Network Drive (Firmware Version 1.30 or Later)	13-46

Chapter 14 Rear Panel Auxiliary I/O Section

△ 14.1	External Trigger Input, External Clock Input, and Trigger Gate Input	14-1
△ 14.2	Trigger Output	14-3
△ 14.3	Video Signal Output (VIDEO OUT (VGA))	14-5

Chapter 15 Other Operations

15.1	Changing the Message Language and Turning ON/OFF the Click Sound	15-1
15.2	Changing the USB Keyboard Language and Checking the Connected USB Keyboard	15-2
15.3	Measuring the Offset Voltage and Applying the Offset Voltage to the Computed Results	15-3
15.4	Setting the Screen Color and Intensity	15-4
15.5	Turning OFF the Backlight and Setting the Brightness of the Backlight	15-6

Chapter 16 Troubleshooting, Maintenance, and Inspection

16.1	Troubleshooting	16-1
16.2	Messages and Corrective Actions	16-2
16.3	Performing a Self-Test	16-8
16.4	Checking the System Conditions (Overview)	16-11
16.5	Recommended Replacement Parts	16-12

Chapter 17 Specifications

17.1	Input Section	17-1
17.2	Logic Input Section (Optional)	17-2
17.3	Trigger Section	17-2
17.4	Time Axis	17-4
17.5	Display	17-4
17.6	Function	17-4
17.7	Built-in Printer (Optional)	17-7
17.8	Storage	17-7
17.9	USB Peripheral Interface	17-8
17.10	Auxiliary I/O Section	17-8
17.11	Computer Interface	17-9
17.12	General Specifications	17-10
17.13	External Dimensions	17-12

Appendix

Appendix 1	Relationship between the Time Axis Setting, Sample Rate and Record Length	App-1
Appendix 2	How to Calculate the Area of a Waveform	App-12
Appendix 3	ASCII Header File Format	App-14
Appendix 4	User-Defined Computation	App-18
Appendix 5	List of Default Settings	App-26
Appendix 6	Key Assignments of the USB Keyboard	App-28

Index



1.1 Front Panel, Rear Panel, and Top Panel

Front Panel

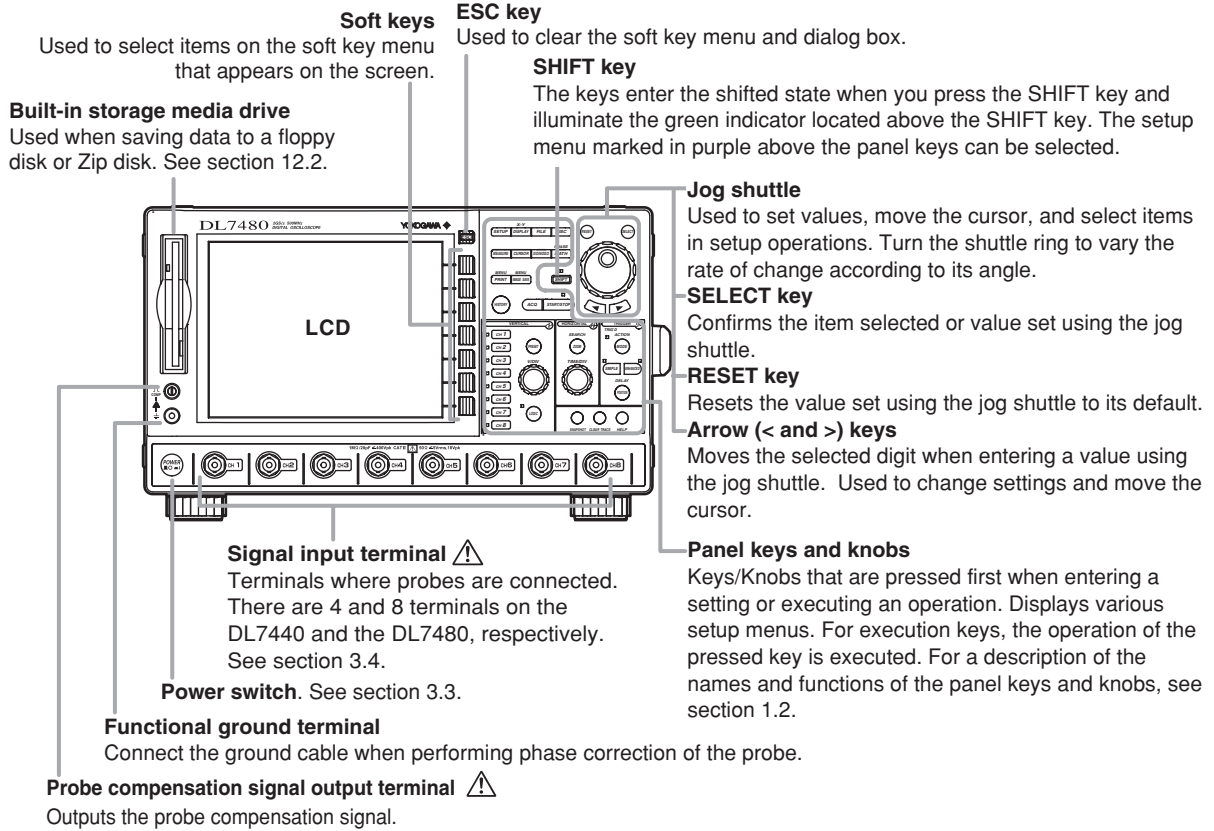

Rear Panel

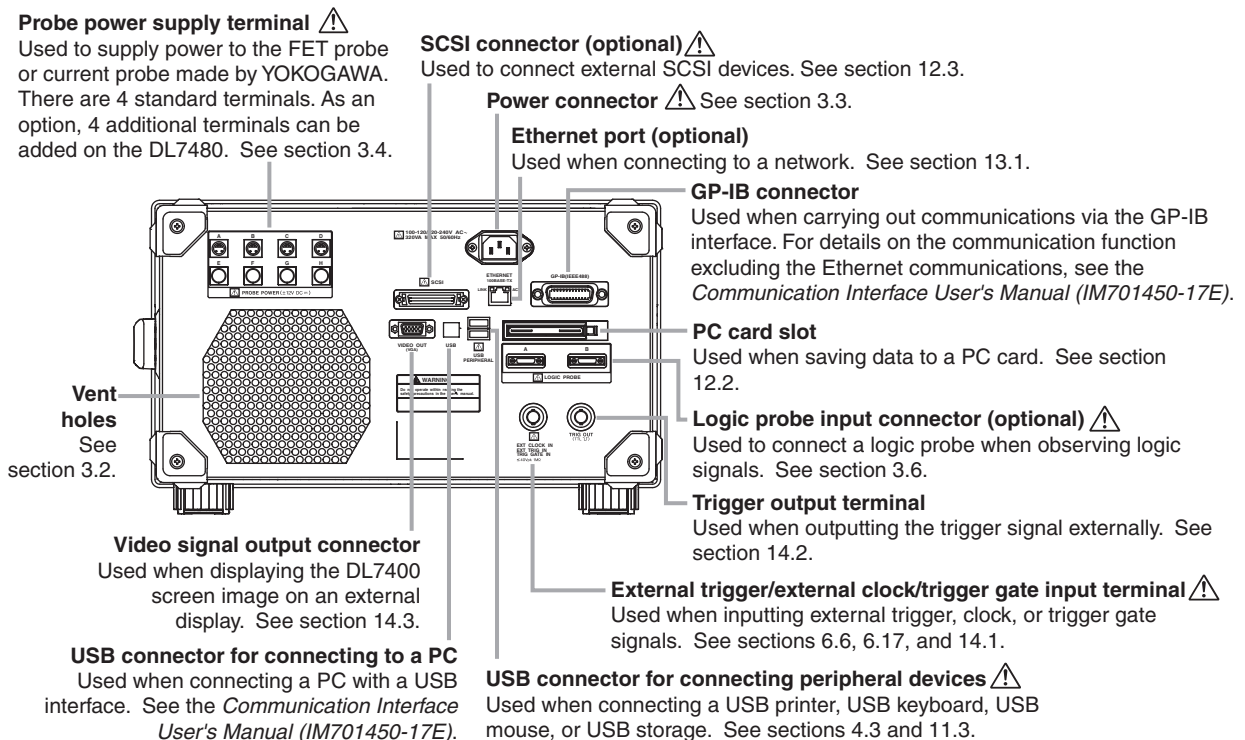

Top Panel

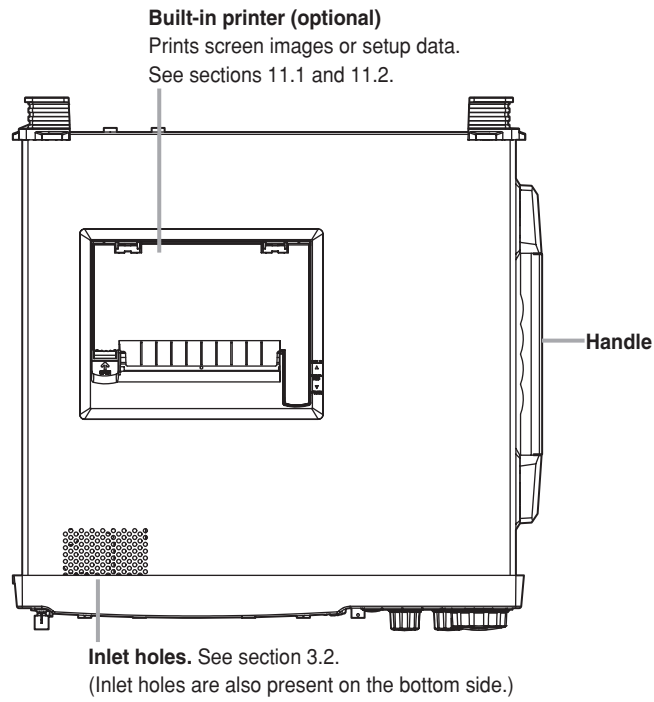

1.2 Panel Keys and Knobs

Vertical Axis

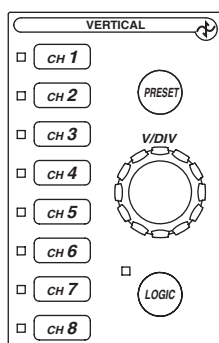

CH1 to CH8/4* Keys (Sections 5.1 to 5.10)

- Each key displays a menu used to turn ON/OFF the channel's display and set the vertical position, coupling, probe attenuation/current-to-voltage conversion ratio, offset voltage, bandwidth limit, expansion or reduction of the vertical axis, linear scaling, and waveform labels.
- If you press a CH key before operating the V/DIV knob to display the menu for the channel, the channel becomes controllable using the V/DIV knob.
- The indicator to the left of each CH key illuminates when the channel is ON.
 - * There are four channel keys (CH1 to CH4) and 8 channel keys (CH1 to CH8) on the DL7440 and DL7480, respectively. The notation "CH1 to CH8/4" is used in the following sections of this manual to indicate that CH1 to CH4 and CH1 to CH8 can be controlled or configured on the DL7440 and the DL7480, respectively.

Note

The setup menu used to specify whether the offset voltage is applied to the measured and computed results is located in the menu that appears when the MISC key (see section 1-5) is pressed.

V/DIV Knob (Section 5.2)

- Sets the vertical sensitivity*.
- Before turning this knob, press one of the CH1 to CH8/4 keys to show the menu for the channel and have the channel selected.
- If you change the vertical sensitivity setting when waveform acquisition is stopped, the new setting takes effect when you restart waveform acquisition.
 - * In the attenuation/current-to-voltage conversion ratio setting of the probe, if the probe attenuation is specified, the voltage sensitivity is set. If the current-to-voltage conversion ratio is specified, the current sensitivity is set.

PRESET Key (Section 5.7)

- Displays a menu used to automatically set the probe attenuation/current-to-voltage conversion ratio, V/div, offset voltage, trigger level, and other parameters to the optimum values for CMOS or ECL signals (or to arbitrary values).
- Presets can also be applied to all channels at once.

LOGIC Key (Section 5.10)

Displays a menu used to turn ON/OFF the display and set the threshold levels and waveform labels on the optional logic input.

Horizontal Axis

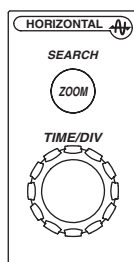

TIME/DIV Knob (Section 5.12)

- Sets the horizontal axis (time axis) scale.
- If you change the setting when waveform acquisition is stopped, the new setting takes effect when you restart waveform acquisition.

ZOOM Key (Section 8.4)

Displays a menu used to set the zoom display of waveforms.

SHIFT+ZOOM (SEARCH) Key (Sections 10.4 and 10.11)

Displays a menu used to set the waveform search (search & zoom function) and the SPI signal analysis and search.

Trigger

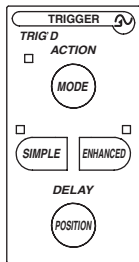

MODE Key (Sections 6.1 and 7.6)

Displays a menu used to set the trigger mode and sequential store.

SHIFT+MODE (ACTION) Key (Section 6.16)

Displays a menu used to set the action-on-trigger.

SIMPLE Key (Sections 6.5 to 6.7)

- Displays a menu used to set the simple trigger (normal edge trigger).
- The simple trigger setting is activated when the indicator located above and to the left of the SIMPLE key is illuminated.

ENHANCED Key Sections (6.8 to 6.15)

- Displays a menu used to set the enhanced trigger (activates complex triggers such as pattern triggers).
- The enhanced trigger setting is activated when the indicator located above and to the left of the ENHANCED key is illuminated.

POSITION Key (Section 6.2)

Displays a menu used to set the trigger position.

SHIFT+POSITION (DELAY) Key (Section 6.3)

Displays a menu used to set the trigger delay.

TRIG'D Indicator

Illuminates when a trigger is activated.

Note

The setup menu for the trigger gate is located in the menu that appears when the MISC key (see page 1-5) is pressed.

Common Operations and Waveform Acquisition, Display, Computation, Analysis, and Search

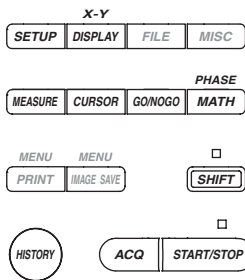

SETUP Key (Sections 4.4, 4.5, and 12.1)

Displays the auto setup menu in which settings can be automatically configured according to the input signal, the initialize menu in which settings can be initialized to their factory defaults, and that allows the user to store/recall setup data.

DISPLAY Key (Sections 8.1 to 8.3 and 8.7 to 8.10)

Displays a menu used to set the waveform display and information display.

SHIFT+DISPLAY (X-Y) Key (Section 8.5)

Displays a menu used to set the X-Y display.

MEASURE Key (Sections 10.6 to 10.8)

Displays a menu used to set the automated measurement of waveform parameters and statistical processing.

CURSOR Key (Section 10.5)

Displays a menu used to set cursor measurements.

GO/NO GO Key (Sections 10.9 and 10.10)

Displays a menu used to set GO/NO-GO determination.

MATH Key (Sections 9.1 to 9.7 and 9.9)

Displays a menu used to set waveform computation.

SHIFT+MATH (PHASE) Key (Section 9.8)

Displays a menu used to set phase shifts.

HISTORY Key (Sections 10.1 to 10.3)

Displays a menu used to display and search waveforms using the history memory function. Waveforms that have been sequentially stored can also be displayed and searched.

ACQ Key (Sections 5.11 and 7.2 to 7.5)

Displays a menu used to set the record length, acquisition mode, interleave mode, sampling mode, time base, and other parameters for waveform acquisition.

START/STOP Key (Section 7.1)

Starts/Stops waveform acquisition according to the trigger mode. Waveform acquisition is in progress when the indicator above the START/STOP key is illuminated.

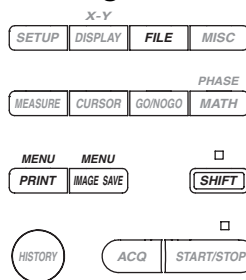
Printing Screen Images and Saving and Loading Data**FILE Key (Sections 12.2, 12.3, 12.6 to 12.11, and 12.13 to 12.16)**

- Displays a menu used to save or load various data from the storage medium (built-in storage medium, external SCSI device, USB storage, or net drive).
- You can display thumbnails of the screen image data that are saved.

PRINT Key (Chapter 11)

Executes the printing of the screen image on a printer (built-in printer, USB printer, or network printer).

SHIFT+PRINT (MENU) Key (Sections 11.2 to 11.4)

Displays a menu used to print screen images on a printer.

IMAGE SAVE Key (Section 12.12)

Executes the saving of the screen image data to a storage medium.

IMAGE SAVE (MENU) Key (Sections 12.12 and 12.13)

- Displays a menu used to save screen image data to a storage medium.
- You can display thumbnails of the screen image data that are saved.

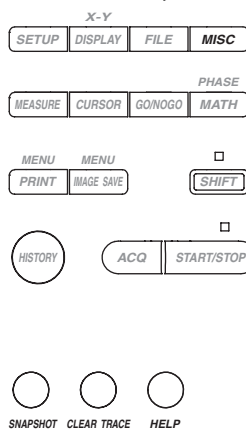
Calibration, Ethernet Communications, and Other Operations**MISC Key**

(Sections 3.7, 4.6, 6.17, 12.4, chapters 13 and 15, sections 16.3, 16.4, and the *Communication Interface User's Manual (IM701450-17E)*)

- Displays a menu used to set the date/time, calibration, trigger gate, SCSI ID number, Ethernet communications, message language, ON/OFF of the click sound, USB keyboard language, ON/OFF of the application of the offset voltage to the measured and computed results, screen color and intensity, backlight, self test, and remote control.
- Displays the setup data and system condition (the presence/absence of options, firmware version, etc.).

SNAP SHOT Key (Section 8.6)

Leaves the current displayed waveform on the screen in black and white (default setting).

CLEAR TRACE Key (Section 8.6)

Clears the snapshot waveforms and accumulated waveforms.

HELP Key (Section 4.7)

Turns ON/OFF the help window that provides description about the procedure.

1.3 Display

Normal Display Screen

Record length/display position
<When displaying normal waveforms>

The length of the green frame indicates the ratio of the display record length with respect to the specified record length.

<When displaying zoom waveforms>

Z1 zoom position **Z2 zoom position**

Internal processing indication
Indicates the current processing status by the color of *.

- Green Computing (power spectrum) or accumulating history waveforms
- Yellow Automated measurement of parameters in progress or searching
- Blue Sending mail, executing a command of the FTP server function, or executing an HTTP command

Specified record length. See section 7.2.

Sample rate. See appendix 1.

Acquisition mode. See section 7.5.

- Normal Normal mode
- Env Envelope mode
- Avg Averaging mode
- BoxAvg Box average mode

If the horizontal axis scale is changed when waveform acquisition is stopped, the new horizontal axis scale and sample rate are displayed highlighted at the position where the acquisition mode is displayed.

Waveform acquisition status

- Stopped
- Running (acquisition in progress)
- Running Pre (acquiring pre data)
- Running Post (acquiring post data)
- Running Waiting for Trigger

Display record length
See appendix 1.

Trigger position mark. See section 6.2.

Horizontal axis scale (time axis T/div)
See section 5.12.

Date/time
See section 3.7.

Label of the displayed waveform
See section 8.9.

Scale value
See section 8.8.

Vertical position mark
See section 5.3.

Ground level mark
See section 2.2.

Trigger level mark
See section 2.3.

Time from the trigger position to the left and right ends of the waveform display frame

Waveform acquisition count

Setup menu

- DISPLAY Format
- Dual
- Interpolation
- Sine
- Graticule
- Scale Value
- OFF [DN]
- Trace Label
- OFF [DN]
- Accumulate
- OFF
- Next (1/2)

Displayed waveform

Vertical axis sensitivity (V/div)
See section 5.2.

Input coupling
See section 5.4.

If the vertical axis scale is changed when waveform acquisition is stopped, the new vertical axis sensitivity is displayed highlighted at the position where the input coupling and bandwidth limit are displayed.

Rectangular frame
Enclosed by a rectangular frame when the channel is being set by V/div.

Bandwidth limit
See section 5.8.

Trigger slope
See section 2.3 and chapter 6.

Trigger source
See section 2.3 and chapter 6.

Trigger level. See section 2.3 and chapter 6.

Trigger mode. See section 6.1.

Trigger type. See section 2.3 and chapter 6.

Comment
Displays the specified comment when printing or saving the screen image.

Probe attenuation/current-to-voltage conversion ratio. See section 5.5.

Note

In some cases, the LCD on the DL7400 may include a few defective pixels. For details, see section 17.5.

Display Example When Displaying X-Y Waveforms

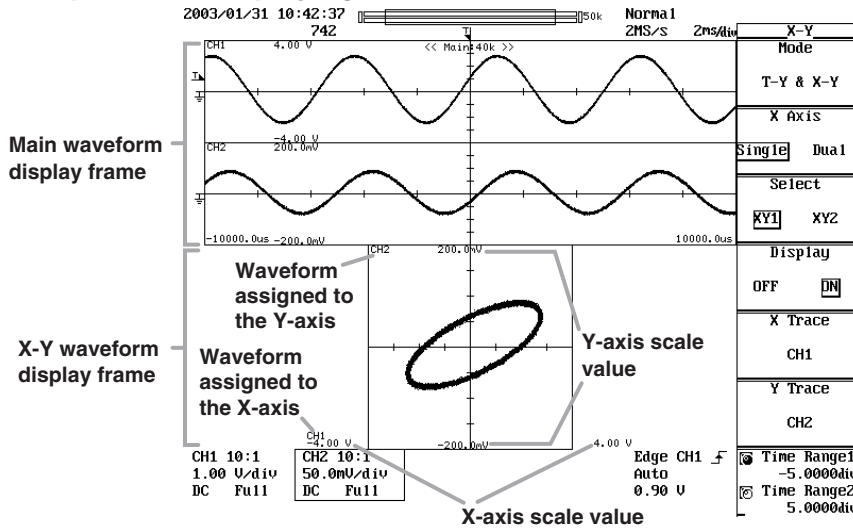

Display Example of the Setup Data List

If you press MISC, then the Next soft key, then the Setup Information soft key, a list of setup data is displayed as shown below. This screen can be printed as additional information (see section 11.2) when the waveforms displayed on the screen (screen image) are printed on the built-in printer (optional).

List of Setup Data Displayed on Both the DL7440 and the DL7480

Setup data related to the vertical axis, trigger, and horizontal axis of CH1 to CH4 is displayed.

Setup Information					MISC	
VERTICAL					LCD	
CH1	CH2	CH3	CH4		Graphic Color	
U/div	1.00 U	50.0mV	1.00 U	0.100 U		
Coupling	DC1M ρ	DC1M ρ	AC1M ρ	DC1M ρ		
Probe	10:1	10:1	10:1	10:1		
Offset	0.00 U	0.0mV	0.00 U	0.000 U		
Position	0.00div	0.00div	0.00div	0.00div		
Bandwidth	Full	Full	Full	Full	Setup Information	
TRIGGER						Self Test
Type	Edge	HORIZONTAL		T/div		
Mode	Auto			Sample Rate		
Position	50.0%			ACQ Mode		
Delay	0.00us			Record Length		
Hold Off	0.00us			Main:50k		
Gate	OFF			Z1 :5k		
Source	CH1			Z2 :500		
					USB	
Level	CH1	CH2	CH3	CH4		Ext
	0.90 U	0.0mV	1.00 U	0.000 U		0.000 U
Slope	\pm	\pm	\pm	\pm		\pm
Coupling	DC	DC	DC	DC		
HFRcj	OFF	OFF	OFF	OFF		
Hys	\neq	\neq	\neq	\neq		
					Back (2/2)	

List of Setup Data Displayed Only on the DL7480

If you press the Setup Information soft key again when the figure above is displayed, the setup data related to the vertical axis, trigger, and horizontal axis of CH5 to CH8 is displayed. The setup data related to the horizontal axis is the same as the setup data displayed on both models in the figure above.

Setup Information					MISC	
VERTICAL					LCD	
CH5	CH6	CH7	CH8		Graphic Color	
U/div	0.100 U	0.100 U	0.100 U	0.100 U		
Coupling	DC1M ρ	DC1M ρ	DC1M ρ	DC1M ρ		
Probe	10:1	10:1	10:1	10:1		
Offset	0.000 U	0.000 U	0.000 U	0.000 U		
Position	0.00div	0.00div	0.00div	0.00div		
Bandwidth	Full	Full	Full	Full	Setup Information	
TRIGGER						Self Test
Type	Edge	HORIZONTAL		T/div		
Mode	Auto			Sample Rate		
Position	50.0%			ACQ Mode		
Delay	0.00us			Record Length		
Hold Off	0.00us			Main:50k		
Gate	OFF			Z1 :5k		
Source	CH1			Z2 :500		
					USB	
Level	CH5	CH6	CH7	CH8		Ext
	0.000 U	0.000 U	0.000 U	0.000 U		
Slope	\pm	\pm	\pm	\pm		
Coupling	DC	DC	DC	DC		
HFRcj	OFF	OFF	OFF	OFF		
Hys	\neq	\neq	\neq	\neq		
					Back (2/2)	

2.1 System Configuration and Block Diagram

System Configuration

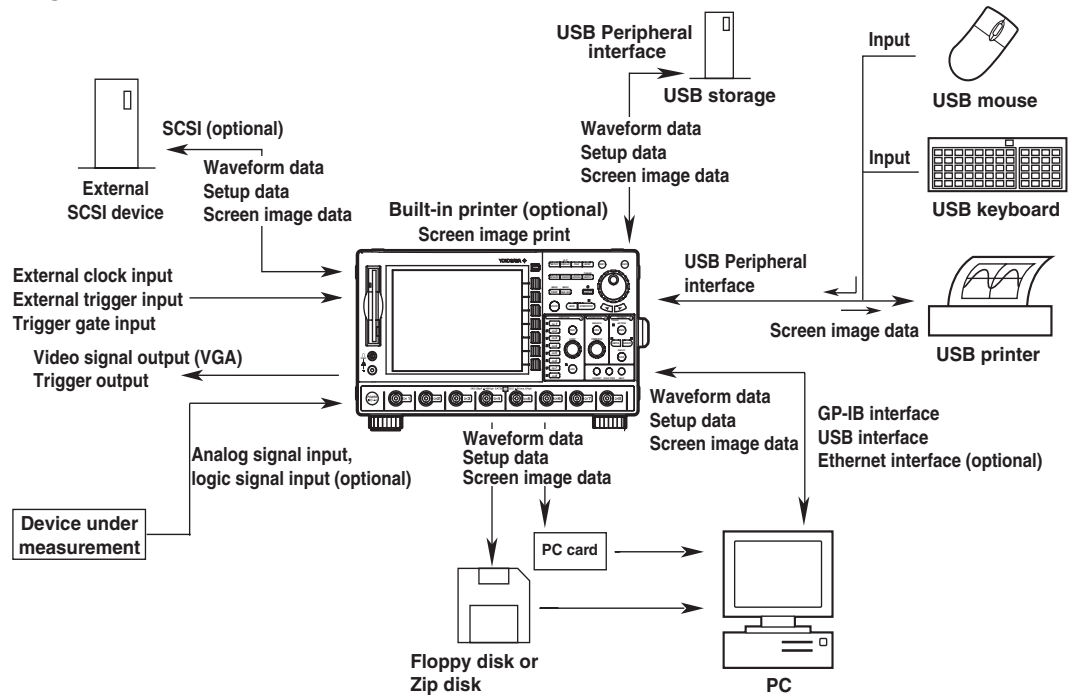

Block Diagram

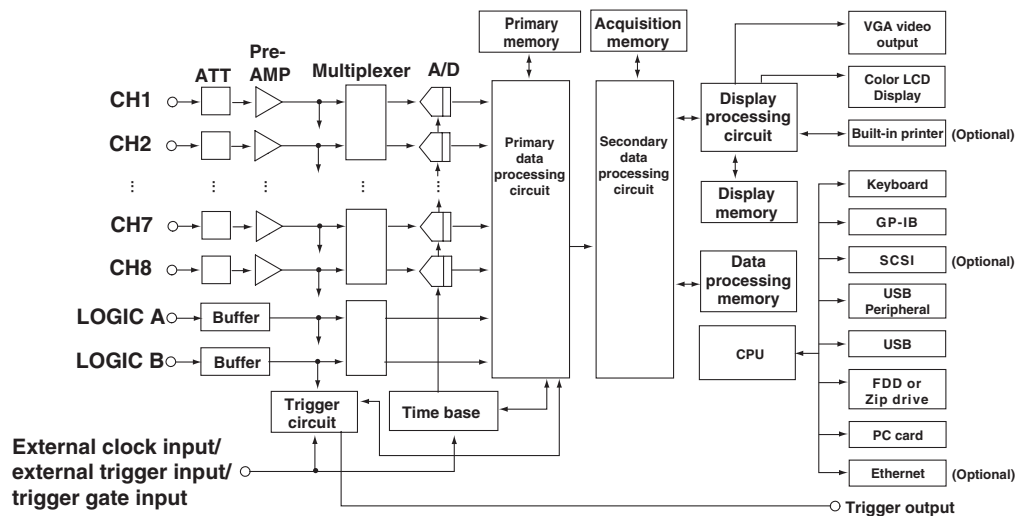

Signal Flow

The signal applied to each signal input terminal is first passed to the vertical control circuit consisting of an attenuator (ATT) and pre-amplifier. At the attenuator and pre-amplifier, the voltage and amplitude of each input signal is adjusted according to the settings such as the input coupling, probe attenuation/current-to-voltage conversion ratio, V/div, and offset voltage. The adjusted input signal is then passed to the multiplexer. The signal input to the multiplexer is passed to the A/D converter according to the time axis and other settings. At the A/D converter, the received voltage level is converted into digital values. The digital data is written to the primary memory by the primary data processing circuit at the sample rate that matches the time axis setting. The data written to the primary memory is processed (averaged, for example) by the secondary data processing circuit and written to the acquisition memory. The data written to the acquisition memory is converted into waveform display data by the secondary data processing circuit, transferred to the waveform processing circuit, and stored in the display memory. The waveforms are displayed on the LCD using the data stored in the display memory.

2.2 Vertical and Horizontal Axes

Vertical Sensitivity <For the setup procedure, see section 5.2>

The vertical sensitivity setting is used to adjust the displayed amplitude of the waveform for easy viewing. The vertical sensitivity is set by assigning a voltage or a current value to one grid square (1 division) on the screen. By switching attenuators with different attenuation and changing the amplification of the pre-amplifier, the sensitivity changes in steps (for example, voltage sensitivity changes in steps as in 1 V/div, 2 V/div, and 5 V/div). In addition, by computing the digital data of the waveforms acquired at the vertical sensitivity described above, the waveforms can be displayed by setting the sensitivity to 0.4 (or 0.5) to 10 times the vertical axis setting that was used to acquire the waveforms (Variable).

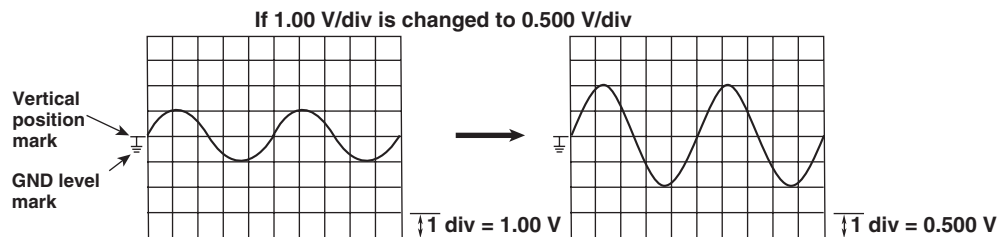

Note

Vertical Sensitivity Setting and Measurement Resolution

To measure the voltage with high accuracy, set the vertical sensitivity so that the input signal is measured with as large an amplitude as possible. The DL7400 uses 8-bit A/D converters to sample the input signal at a resolution of 255 levels (LSB). On the screen, the waveforms are displayed using 24 levels per division on the grid.

Valid Data Range

Assuming that the output value from the A/D converter is in the range of 0 to 255, the data point at the center of the screen corresponds to 128 of the A/D output. However, because the full range of the A/D converter is 255 levels, the 256th level on the screen is not used. In addition, the DL7400 handles the output values of the A/D converter as 0s and 1s. Therefore, the valid data range of the DL7400 is approximately ± 5.29 divisions from the center of the screen. If the vertical axis position is moved after stopping data (waveform) acquisition, the valid data range also moves by the same amount.

Vertical Position of the Waveform <For the setup procedure, see section 5.3>

Since the DL7400 is capable of displaying 8 channels (4 channels on the DL7440) of input waveforms, the waveforms may overlap making them difficult to be observed. In this case, you can change the display position of waveforms along the vertical axis (vertical position) in the range of ± 4 divisions for easier viewing. The vertical sensitivity switches around the vertical position (mark).

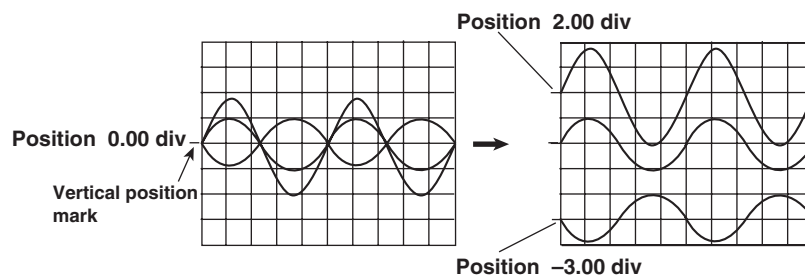

Input Coupling <For the setup procedure, see section 5.4>

If you wish to observe just the amplitude of an AC signal, it is best to remove the DC component from the input signal. On the other hand, there are times when you wish to check the ground level or observe the entire input signal (both the DC and AC components). In these cases, you can change the input coupling setting. By changing the input coupling, the method used to input the signal to the vertical control circuit (voltage axis) is switched. The following types of input coupling are available.

AC1M Ω

The input signal is coupled to the attenuator of the vertical control circuit through a capacitor. This setting is used when you wish to observe only the amplitude of the AC signal, eliminating the DC component from the input signal.

DC1M Ω

The input signal is directly coupled to the attenuator of the vertical control circuit. Use this setting if you wish to observe the entire input signal (DC component and AC component).

DC50 Ω

This setting is similar to DC1M Ω described above except the input impedance is 50 Ω . Use caution because the maximum input voltage is decreased.

GND

The input signal is coupled to the ground, not to the attenuator of the vertical control circuit. You can use this setting to check the ground level on the screen.

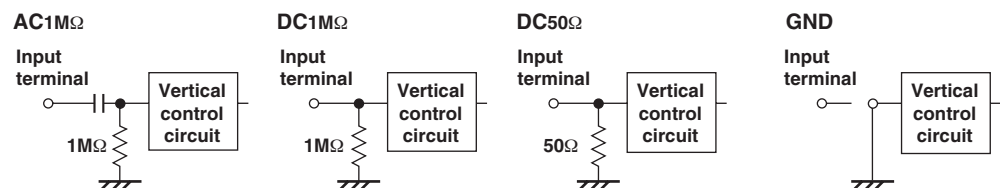
**Probe Attenuation/Current-to-Voltage Conversion Ratio <For the setup procedure, see section 5.5>**

Normally a probe is used in connecting the circuit being measured to the measurement input terminal. Using a probe has the following advantages.

- Avoids disturbing the voltage and current of the circuit being measured.
- Inputs the signal with no distortion.
- Expands the voltage range that the DL7400 can measure.

The DL7400 comes standard with 400 MHz passive probes. The probe attenuates the voltage signal to 1/10. When using a probe, the attenuation setting on the DL7400 must be set equal to the probe attenuation so that the measured voltage can be read directly. When using the 400-MHz passive probes (voltage probes) that came with the package, set the probe attenuation to 10:1. The DL7400 has voltage probe settings of 10:1, 1:1, 100:1, and 1000:1 and current probe settings of 10 A:1 V and 100 A:1 V. If you are using a probe other than the ones that came with the package, set the attenuation ratio on the DL7400 according to the attenuation of the probe.

Offset Voltage <For the setup procedure, see section 5.6>

When observing a voltage riding on top of a predetermined voltage, an offset voltage can be applied to eliminate the predetermined voltage so that only the changes in the signal can be observed with higher vertical axis sensitivity. Usually, the offset voltage does not affect the cursor measurement values, the result of the automated measurement of waveform parameters, or the computed values. However, you can apply the offset voltage to cursor measurement values, the result of the automated measurement of waveform parameters, and the computed values by setting Offset Cancel to ON (see section 15.3).

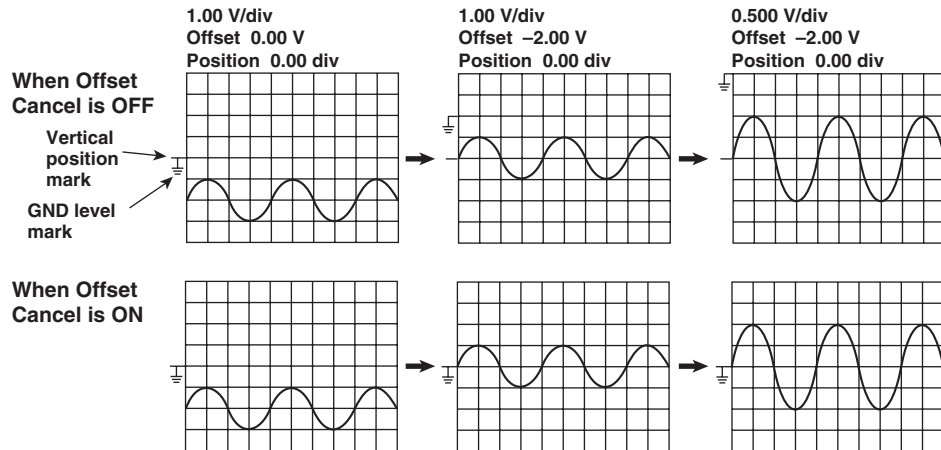

Bandwidth Limit <For the setup procedure, see section 5.8>

You can set a bandwidth limit at 20 MHz or 100 MHz against the input signal for each channel. You can observe waveforms with the noise components above the specified frequency eliminated.

Linear Scaling <For the setup procedure, see section 5.9>

When observing voltages or currents, you can change the vertical axis scale values of the displayed waveforms (see page 2-20) to scaled values. By setting scaling coefficient A, offset value B, and a unit, you can multiply the division ratio of an external voltage divider or convert the voltage measurement to current values. Linear scaling also applies to the measured values of cursor measurements and automated measurement of waveform parameters.

$$Y \text{ (UNIT)} = AX + B$$

X: Value before scaling

Y: Value after scaling

Logic Signal Input (Optional) <For the setup procedure, see section 5.10>

You can observe logic signals by connecting a logic probe to the logic probe input connector on the rear panel. Two logic input ports, Pod A and Pod B, are available. Each pod can receive 8 bits.

Horizontal Axis (Time Axis)

Selecting the Time Base <For the setup procedure, see section 5.11>

By default, the sampling timing of the measured waveform is controlled by the internal clock signal generated from the time base circuit within the DL7400 (see the block diagram in section 1.1). The timing can also be controlled by a clock signal applied externally. External clock signals are input through the external clock input terminal on the rear panel. The external clock input is useful for observing a signal whose period varies or for observing waveforms by synchronizing to the clock signal of the signal being measured.

Time Axis Setting <For the setup procedure, see section 5.12>

When using the internal clock, the time axis scale (T/div) is set in terms of the time per one grid square (1 division). The selectable range is 1 ns/div to 50 s/div (1 ns/div to 5 s/div when the record length is 1 k.) Since the display span along the horizontal axis is 10 divisions, the time span of the displayed waveform is equal to "T/div×10."

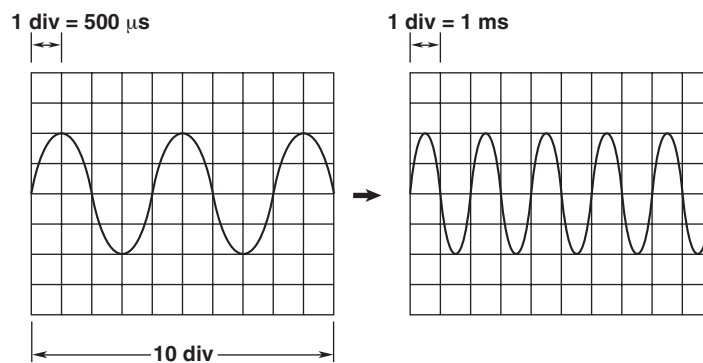

Display along the Time Axis

Sampled data of the length equal to the specified record length is acquired to the acquisition memory, and waveforms are displayed based on the stored data. The number of display lines in 10 divisions of the screen (along the time axis) is 500 (250 lines in the zoom waveform display section of Main & Z1 & Z2). Therefore, the waveforms are processed according to the display record length (see page 2-15) as described below. For more details about the relationship between the time axis, acquisition mode, record length of the acquisition memory (specified record length), display record length, and other parameters, see appendix 1.

- When the display record length is greater than the number of displayed points
The multiple data points existing on the same display line on the time axis are connected by a line and displayed.
- When the display record length is less than the number of displayed points
Display interpolation is performed (see section 2.4).

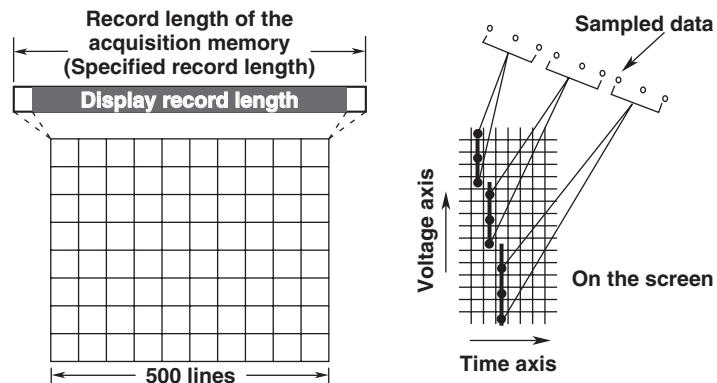

Relationship between the Specified Record Length, Time Axis Setting, Sample Rate, and Display Record Length

If you change the time axis setting with respect to the specified record length of the acquisition memory, the sample rate and display record length change. (For more details about this relationship, see appendix 1.

Relationship between the Time Axis Setting and Sampling Mode

Depending on the time axis setting, you can switch the mode used to sample the input signal (sampling mode). The time axis settings that allow the sampling mode to be changed vary depending on the acquisition mode and other settings. For details, see appendix 1.

Realtime Sampling Mode

Changing the time axis setting changes the sample rate. Data can be sampled at up to 2 GS/s (1 GS/s when interleave mode is OFF. For a description of interleave mode, see section 2.4). The input signal is sampled sequentially, and the data is stored in the acquisition memory. In this mode, the DL7400 can only display waveforms correctly up to one-half the frequency of the sample rate (the number of samples per second, in units of S/s) as defined by the sampling theorem.* Therefore, this mode is best suited for observing waveforms whose frequency is low relative to the sample rate.

* If the sample rate is comparatively low with respect to the input signal frequency, the harmonics contained in the signal are lost. In this case, some of the harmonics will appear at low frequencies due to the effects described by the Nyquist sampling theorem. This phenomenon is called *aliasing*. You can prevent aliasing by acquiring waveforms with the acquisition mode set to envelope.

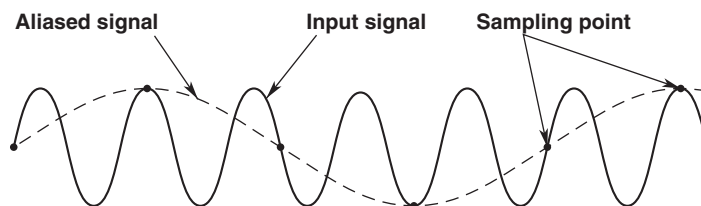

Repetitive Sampling Mode

In repetitive sampling mode, you can set the time axis to a setting that will cause the sample rate to exceed 2 GS/s (5 GS/s when interleave mode is ON). In this mode, one waveform is created from several cycles of a repetitive signal. This is equivalent to sampling the signal at a higher sample rate than the actual sample rate. The maximum apparent sample rate is 100 GS/s on the DL7400. In addition, even in realtime sampling mode, if the relationship of the time axis and the display record length would cause the sample rate to exceed 2 GS/s (5 GS/s when interleave mode is ON), the mode automatically switches to repetitive sampling.

There are two types of repetitive sampling. One is *sequential sampling* in which the data is sampled by intentionally offsetting the sampling points by a certain time with respect to the trigger point. The other is *random sampling* in which the data that is offset randomly from the trigger point is sampled and resorted with respect to the trigger point. The DL7400 employs random sampling which enables the waveform before the trigger point (trigger position, see section 2.3) to be observed.

Time Axis Setting and Roll Mode Display

If T/div is set to a certain range (see appendix 1), the waveforms are displayed in roll mode. In roll mode, the displayed waveform is not updated using triggers (update mode). Rather, the oldest data is deleted as new data is acquired, and the waveform is shifted from right to left on the screen. Roll mode display allows waveforms to be observed in the same way as on a pen recorder. It is useful in observing low frequency signals or signals that change slowly. It is also useful in detecting glitches (spikes in the waveform) that occur intermittently.

* Roll mode display is also used when the trigger mode is set to single. However, the displayed waveforms stop when a trigger is activated.

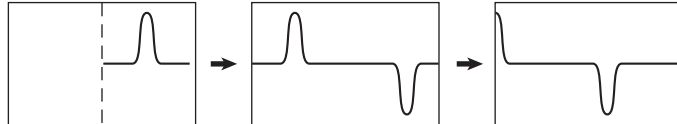

2.3 Trigger

A *trigger* is a cue used to display the waveform on the screen. The trigger is activated when the specified trigger condition is met. At this point, the waveform is ready to be displayed on the screen.

Trigger Source, Trigger Slope, and Trigger Level

Trigger Source

Trigger source refers to the signal that is used in checking the trigger condition.

Trigger Slope

Trigger slope refers to the movement of the signal from a low level to a high level (rising edge) or from a high level to a low level (falling edge). When the slope is used as one of the trigger conditions, it is called a trigger slope. *Edge* refers to the point where the trigger source slope passes the trigger level (or, when trigger hysteresis (see page 2-14) is specified, the point where the slope passes the hysteresis level).

Trigger Level

Trigger level refers to the level at which a trigger is activated when the trigger source passes the certain level.

With simple triggers such as the edge trigger described later, a trigger is activated when the level of the trigger source passes through the specified trigger level.

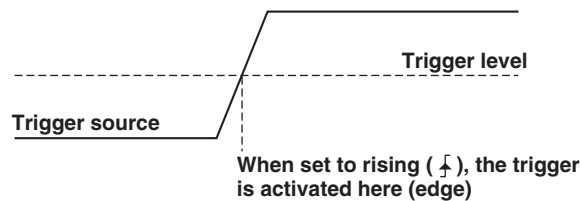

Trigger Type <For the setup procedure, see chapter 6>

The trigger used on the DL7400 can be classified into two main types: *simple trigger* and *enhanced trigger*.

Simple Trigger

This function activates a trigger on a single trigger source.

Edge Trigger <For the setup procedure, see sections 6.5 to 6.7>

When the slope of the trigger source passes through the specified trigger level on a rising or falling edge, a trigger is activated. You can select the trigger source from input signals, the external trigger signal, and the commercial power supplied to the DL7400. In the case of commercial power, a trigger is activated only on the rising edge.

Enhanced Trigger

Multiple conditions or a special-purpose condition can be specified as a trigger condition.

A->B(N) Trigger <For the setup procedure, see section 6.8>

A trigger is activated the n^{th} time condition B becomes true after condition A has become true.

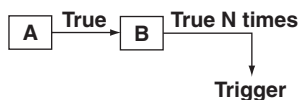

Condition A: CH1 = L, CH2 = L, Enter, Condition B: CH1 = H, CH2 = H, Enter, N = 3
L: low level, H: high level

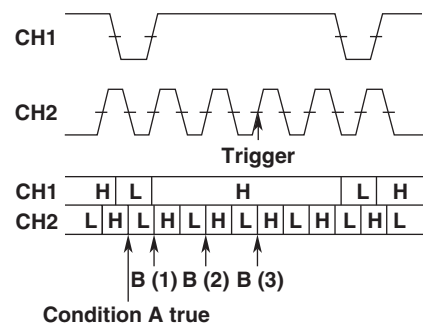

A Delay B Trigger <For the setup procedure, see section 6.9>

A trigger is activated the first time condition B becomes true after condition A has become true and the preset time (Delay Time) has elapsed.

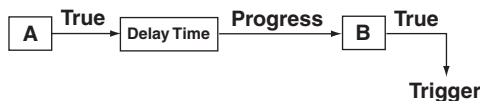

Condition A: CH1 = L, CH2 = L, Enter, Condition B: CH1 = H, CH2 = H, Enter, Delay = 1 μ s

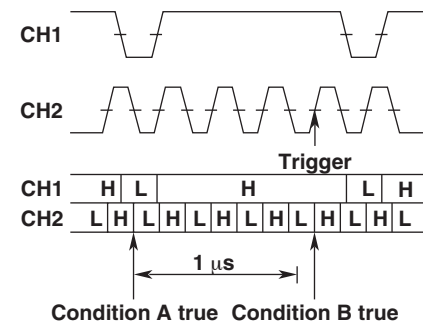

2.3 Trigger

Pattern Trigger <For the setup procedure, see section 6.10>

With pattern triggers, the trigger source is set to multiple signals. A trigger is activated when all of the trigger conditions of the trigger sources are met or when the trigger conditions are no longer met. Trigger conditions are specified by combining the status (high or low) of each trigger source. In addition, one of the trigger sources can be set to the clock signal, and the trigger can be activated in sync with the clock signal.

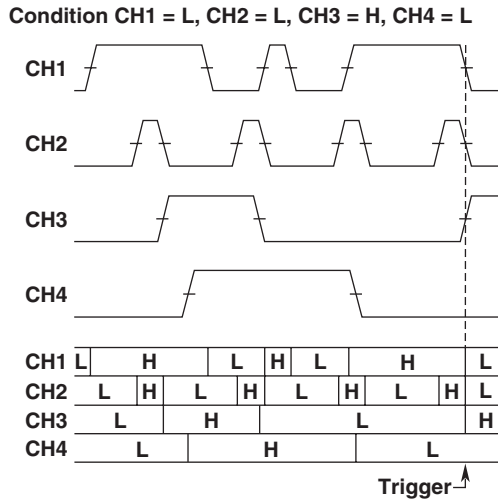

Width Trigger <For the setup procedure, see section 6.11>

A trigger is activated by determining whether the time over which the specified condition is met or not met is shorter or longer than the determination time set in advance. The condition is set on the AND logic of the status (High, Low, or Don't Care) of each channel or the AND logic of the window condition (IN, OUT, or Don't Care) of each channel.

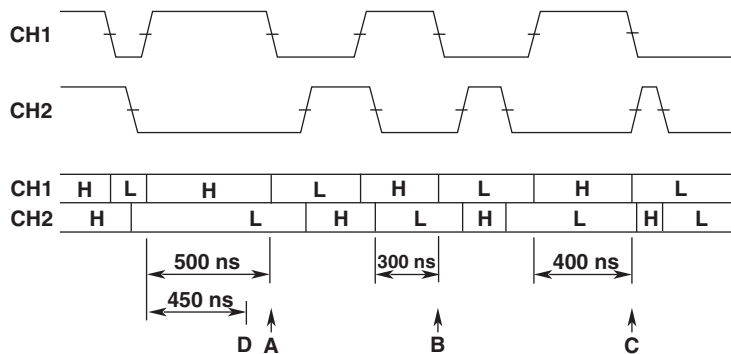

When the condition is set to CH1 = H, CH2 = L, CH3 = X, CH4 = X, Condition = True, and Time = 350 ns

Determination type Pulse<Time	Trigger is activated at point B.
Determination type Pulse>Time	Trigger is activated at points A and C.
Determination type T1<Pulse<T2 Time1 = 350 ns and Time 2 = 450 ns	Trigger is activated at point C.
Determination type Time Out Time = 450 ns	Trigger is activated at point D.

OR Trigger <For the setup procedure, see section 6.12>

A trigger is activated when any of the edge or window conditions specified on each channel are met. For example, a trigger can be activated on the rising edge of CH1 or CH2.

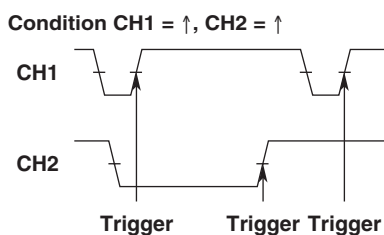
**Window Trigger <For the setup procedure, see section 6.13>**

A certain voltage range (window) is set and a trigger is activated when the trigger source level enters this voltage range (IN) or exits from this voltage range (OUT). This trigger is used in combination with the OR or Width trigger. The window trigger setting is located in the OR or Width trigger menu.

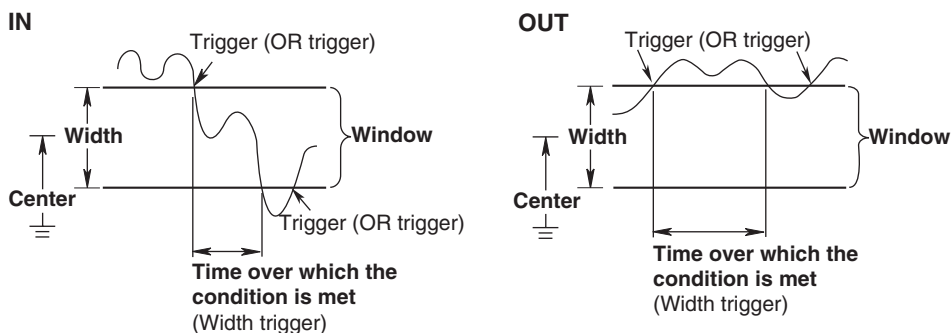
**TV Trigger <For the setup procedure, see section 6.14>**

This trigger is used when observing video signals. The following broadcasting types are supported: NTSC, PAL, SECAM, 1080/60i, 1080/50i, 720/60p, 480/60p, 1080/25p, 1080/24p, 1080/24sF, and 1080/60p.

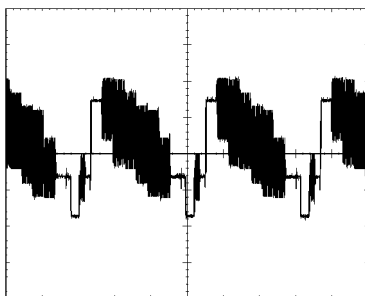

2.3 Trigger

Logic Trigger <For the setup procedure, see section 6.15>

The DL7400 has two logic probe input connectors, A and B. Each pod can receive 8 bits of logic signals. A trigger is activated on the rising or falling edge of the clock bit while the condition consisting of the combination of H, L, and Don't Care of Pod A and B (16 bits) is met. If the clock bit is not specified, a trigger is activated on whether the condition consisting of the combination of the logic input is met or not met.

Condition Pod A Bit0 = L, Pod A Bit1 = L, Pod A Bit2 = H, Pod A Bit3 = L,
True, Rising edge ↑ of Clock Bit A4 (PodA Bit4)

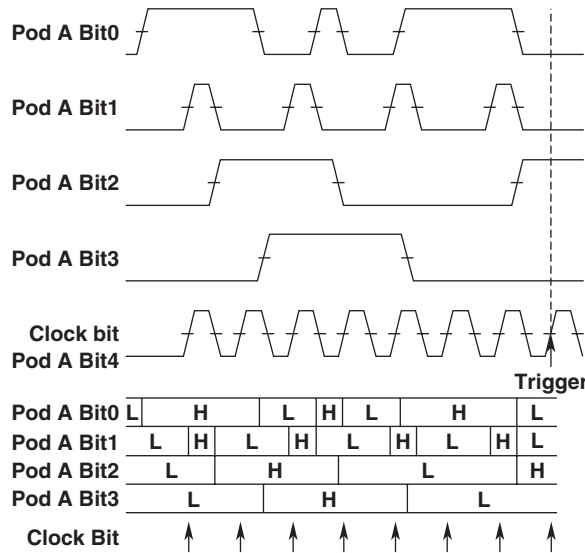

Trigger Mode <For the setup procedure, see section 6.1>

Sets the conditions for updating the displayed waveforms. The following five trigger modes are available.

Auto Mode

If a trigger occurs within a specified amount of time (approximately 100 ms, referred to as the *timeout time*), the displayed waveforms are updated. If a trigger is not activated within the timeout time, the displayed waveforms are automatically updated.

Auto Level Mode

If a trigger occurs within the timeout time, the waveform is displayed in the same fashion as in auto mode. If a trigger is not activated within the timeout time, then the center value of the amplitude of the trigger source is detected, and the trigger level is changed to that value. A trigger is activated using the new value, and the displayed waveforms are updated.

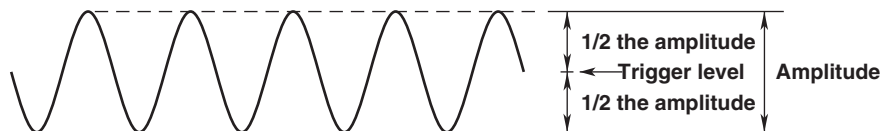

Normal Mode

The displayed waveforms are updated only when a trigger occurs. The displayed waveforms are not updated if a trigger does not occur.

Single Mode

When a trigger is activated, displayed waveforms are updated only once, then acquisition stops. This mode is useful when you are observing a single-shot signal.

Single (N) Mode

Waveforms are acquired and stored in different memory areas each time a trigger is activated the specified number of times. Then, acquisition is stopped, and all the acquired waveforms are displayed. For details on the acquisition method of waveforms in Single (N) mode, see “Sequential Store” on page 2-17.

Trigger Position <For the setup procedure, see section 6.2>

When you start waveform acquisition, a trigger is activated according to a specified trigger condition, and the waveform acquired to the acquisition memory is displayed. If the trigger delay described below is set to 0 s, the point at which the trigger is activated (trigger point) and the trigger position match. By moving the trigger position on the screen, you can change the display ratio of the pre-data—the waveform data stored in the acquisition memory before the trigger point (pre-trigger section)—and the post-data—data after the trigger point (post-trigger section).

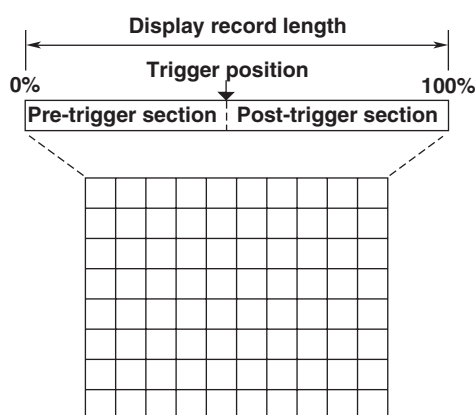

Trigger Delay <For the setup procedure, see section 6.3>

Normally, the waveform around the trigger point is displayed. However, by setting a trigger delay, you can display the waveform that is acquired a specified time after the trigger point. The selectable range of trigger delay is 0 to 4 s.

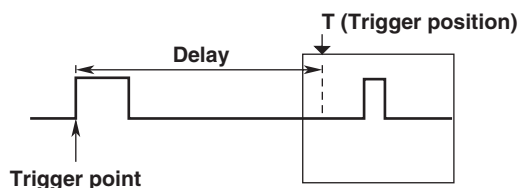

Trigger Coupling <For the setup procedure, see sections 6.5, 6.8 to 6.12>

As with the input signals, the input coupling can be switched on trigger sources. Select the input coupling that is suitable for the trigger source signal. The following two types of input coupling are available for the trigger source signal.

DC

Select this setting when using the source as is with no processing of the signal.

AC

Select this setting when using the signal with the DC components removed for the trigger source. When this setting is used, a trigger can always be activated on signals whose amplitude is around 1 division or greater if the trigger level is set to 0 V.

HF Rejection <For the setup procedure, see sections 6.5, 6.8 to 6.12>

Turn HF rejection ON when eliminating high frequency components above 15 kHz or 20 MHz from the trigger source. This prevents triggers from being activated at unexpected points due to the effect of high frequency noise.

Trigger Hysteresis <For the setup procedure, see sections 6.5, 6.8 to 6.12>

If there is insufficient trigger level width and noise is present in the trigger source, the trigger point fluctuates each time a trigger is activated. This causes the displayed waveforms to be unstable. Therefore, a given margin (hysteresis) is added to the specified trigger level. You can select ∇ (narrow hysteresis) or ∇ (wide hysteresis) on the DL7400. When set to ∇ , the hysteresis is set wide reducing the fluctuation of the trigger point caused by noise. Thus, a stable waveform display is achieved. However, this setting tends to make the trigger point ambiguous. On stable waveforms without noise, set the hysteresis to ∇ to make the trigger point more accurate.

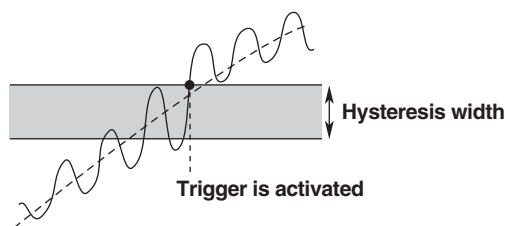

Trigger Hold Off <For the setup procedure, see section 6.4>

The trigger hold-off function temporarily stops detection of the next trigger once a trigger has been activated. This function is useful when observing a pulse train signal, such as a PCM code and you wish to display the waveform in sync with repetitive cycles; or when using the history memory function described later (see page 2-17) and you want to change the waveform acquisition period.

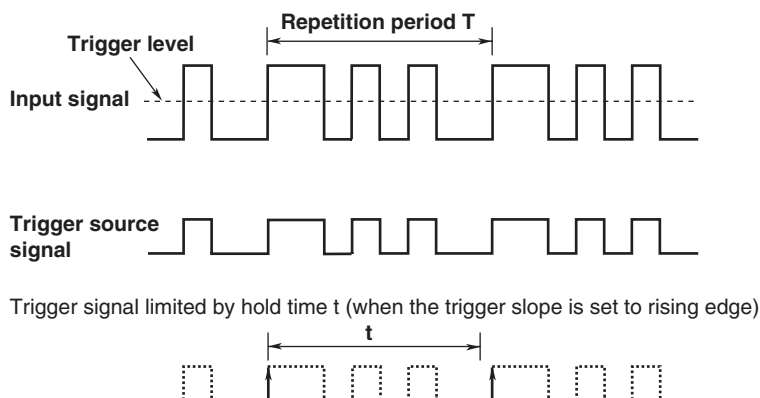

Action-on-Trigger <For the setup procedure, see section 6.16>

A specified action can be executed each time a trigger is activated. You can select from various actions including sounding of a buzzer, saving of waveform data or screen image data, printing of screen image data, or transmission of e-mail messages (when the Ethernet interface option is installed).

Trigger Gate <For the setup procedure, see section 6.17>

You can control whether to enable a satisfied trigger condition using an external signal. You can also select the status of the external signal that enables the satisfied trigger condition.

2.4 Waveform Acquisition and Display Conditions

Record Length <For the setup procedure, see section 7.2>

The term *record length* refers to the number of data points acquired per channel in the acquisition memory. The record lengths that can be specified (specified record length) are 1 kW (1000 points), 10 kW, 50 kW, 100 kW, 250 kW, 500 kW, 1 MW, 2 MW, 4 MW, 8 MW, and 16 MW. The maximum record length that can be specified varies depending on the model and interleave mode setting. *Displayed record length* refers to the number of these data points that are actually displayed on the screen. When the time axis setting is changed, the sample rate and display record length change (see appendix 1). In most cases, the displayed record length is identical to the (acquisition) record length. For certain time-axis settings, however, the lengths become different (see appendix 1).

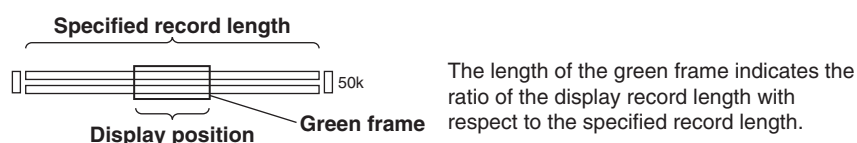

Interleave Mode <For the setup procedure, see section 7.3>

This mode allocates the memory of even channels to the odd channels to enable the use of twice the normal memory. When interleave mode is turned ON, even channels can no longer be used, but parameters such as the history memory, acquisition count of sequential store, and record length can be set twice their normal values. In addition, since two A/D converters can be used to sample a single input signal and raise the maximum sample rate, a sample rate of 2 GS/s can be achieved in realtime sampling mode. For the relationship between interleave mode, time axis, record length, and sample rate, see appendix 1.

Sampling Mode <For the setup procedure, see section 7.4>

As explained in “Relationship between the Time Axis Setting and Sampling Mode” in section 2.2, the sampling mode can be switched between realtime sampling mode and repetitive sampling mode depending on the time axis and record length settings. The time axis range that allows repetitive sampling mode varies depending on the acquisition setting. For details, see appendix 1.

Acquisition Mode <For the setup procedure, see section 7.5>

When storing sampled data in the acquisition memory (see “Signal Flow” in section 2.1), it is possible to perform processing on data and display waveforms based on the processed data. The following four types of data processing are available.

Normal Mode

In this mode, sampled data is stored in the acquisition memory without processing.

Envelope Mode

In normal mode and averaging mode, the sample rate (the number of times data is acquired per second in the acquisition memory) drops if T/div is increased (see appendix 1). However, in envelope mode, the maximum and minimum values are determined from the data sampled at 1 GS/s or 800 MS/s at time intervals one half that of the sampling period (inverse of the sample rate) of normal mode regardless of the interleave mode setting (ON or OFF). The maximum and minimum values are stored as pairs in the acquisition memory.

Envelope mode is useful when you want to avoid aliasing (see section 2.2), since the sample rate is kept high irrespective of the time axis setting. It is also useful when you want to detect glitches (pulse signals which rise very fast) or display an envelope of a modulating signal.

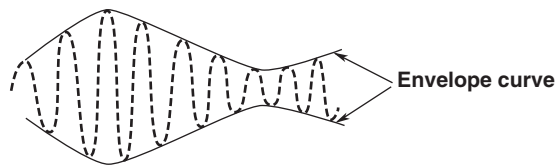

Averaging Mode

Averaging is a process in which waveforms are acquired repeatedly to obtain the average of waveform data at the same time point (the same time in relation to the trigger point). The DL7400 takes the exponential or simple average of the waveform data and writes the results to the acquisition memory. The averaged data is then used to generate the display. This mode is useful such as when eliminating the random noise riding on the signal. The attenuation constant of exponential averaging can be set in the range of 2 to 256 (2ⁿ steps, where n is a positive integer). The average count of simple averaging can be set in the range of 2 to 65536 (2ⁿ steps, where n is a positive integer).

Exponential averaging (when set to infinite)

$$A_n = \frac{1}{N} \{(N-1)A_{n-1} + X_n\}$$

A_n : nth averaged value
 X_n : nth measured value

N : Attenuation constant (2 to 256, 2ⁿ steps)

Simple average (when set to 2 to 65536)

$$A_N = \frac{\sum_{n=1}^N X_n}{N}$$

X_n : nth measured value
 N : Average count

(acquisition count, 2ⁿ steps)

Box Average

The moving average of the data sampled at 1 GS/s or 800 MS/s is determined regardless of the interleave mode setting (ON/OFF). The resultant data is stored in the acquisition memory and displayed. Box averaging is useful for eliminating small amounts of noise from the input signal. It can also remove noise from a single-shot signal.

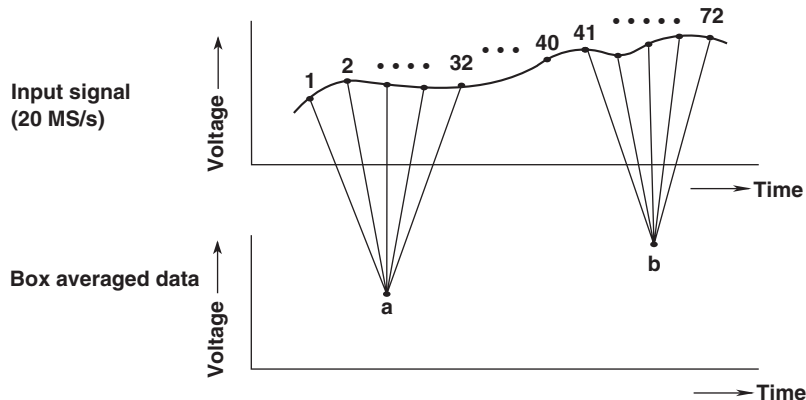

Sequential Store <For the setup procedure, see section 7.6>

This function stores waveform data in the acquisition memory the specified number of times and displays the data when in realtime sampling mode. The operation stops when acquisition is finished. This function operates when the trigger mode is set to Single (N). The maximum number of waveform acquisitions of sequential store varies from 1 to 4096 depending on the specified record length, interleave mode, and model. Once the specified number of waveforms have been stored, you can display any of the waveforms individually or all of them together. This function is useful when capturing the changes in the waveform over time. Waveforms are not displayed while waveform acquisition is in progress. The figure below shows an example when data is sequentially stored 100 times.

Display example when the acquisition count is 100

- Display all waveforms (when all display is executed)
- Display the newest waveform (when Select Record = 0)
- Display the oldest waveform (when Select Record = -99)

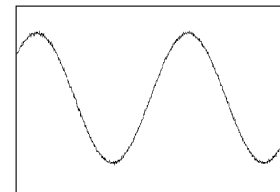
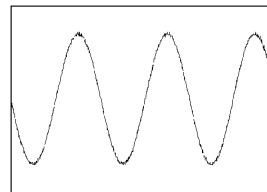
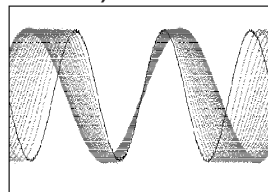
**History Memory <For the setup procedure, see section 10.1>**

When waveforms are being measured, the waveform data stored in the acquisition memory as a result of a trigger being activated is displayed as waveforms on the DL7400 screen. When triggers are continuously activated and waveforms are acquired, it is impossible to stop the measurement in time when an abnormal waveform appears (newer waveforms appear on the screen). Normally, abnormal waveforms in the past cannot be displayed. However, by using the history memory function, the past waveform data (history waveforms including the current displayed waveform) stored in the acquisition memory can be displayed when waveform acquisition is stopped. You can display a specified history waveform from the data (up to 4096 waveforms or the number of triggers) stored in the acquisition memory. In addition, a certain history waveform can be searched (see section 2.6). The number of waveforms N that can be acquired and held as history waveforms varies from 1 to 4096 depending on the record length, interleave mode setting, and model. If the number of waveforms N that can be acquired and held is exceeded, the oldest history waveform is cleared. The waveform currently displayed on the screen (newest waveform) is counted as the 1st waveform, and up to N-1 waveforms in the past can be displayed. The following figure indicates an example when N = 1024.

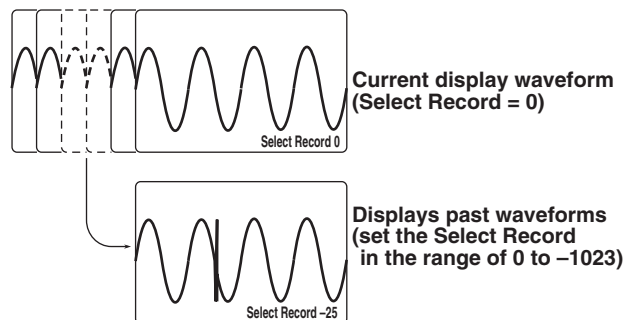
Holds waveform data of the last 1024 triggers

Display Format <For the setup procedure, see section 8.1>

Splitting the Screen

The screen can be split evenly so that input waveforms and computed waveforms can be easily viewed. The screen can be divided into the following:
 Single (no division), Dual (two divisions), Triad (three divisions), Quad (four divisions), Hexa (six divisions), and Octal (eight divisions, DL7480 only)

Waveform Mapping

You can select the mapping of the input channels to the divided windows.

Auto	Waveforms whose display is turned ON are assigned in order from the top.
Fixed	Waveforms are assigned in order from the top regardless of whether the display is turned ON or OFF.
User	The waveforms can be assigned arbitrarily to the divided windows regardless of whether the display is turned ON or OFF.

Displaying Waveforms and Logic Signals

When displaying logic signals on the screen, the normal waveforms and logic signals can be displayed simultaneously on divided windows or only the logic signals can be displayed over the entire screen.

Display Interpolation <For the setup procedure, see section 8.2>

In *interpolation areas* where less than 500 points of data exists in 10 divisions along the time axis (or less than 250 points in the zoom display section when waveforms are zoomed in Main&Z1&Z2), a continuous waveform cannot be displayed because there are not enough sampled points. In this case, the waveform is displayed by interpolating between data points. You can select the interpolation method.

Sine Interpolation

Generates interpolation data using the function $\frac{\sin x}{x}$ then interpolates between two dots using the resulting sine curve. Sine interpolation is suitable for observing sine waves or similar waves.

Linear Interpolation

Linearly interpolates between two points.

Pulse Interpolation

Interpolates between two points in a step pattern.

Interpolation OFF

Displays discrete dots without performing interpolation.

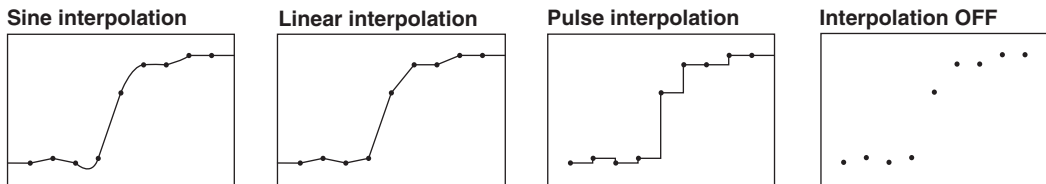

Accumulated Display <For the setup procedure, see section 8.3>

The display time of old waveforms can be set longer than the waveform update period, so that newer waveforms appear overlapped (accumulated) on older waveforms. The following two modes are available. Accumulated display is useful when observing jitters and temporary turbulence in waveforms.

Persist	Accumulates waveforms using a single color for each channel.
Color	Accumulates waveforms using eight colors indicating data frequency information.

Zooming the Waveform <For the setup procedure, see section 8.4>

The displayed waveform can be expanded along the time axis. This function is useful when the waveform acquisition time is set long and you wish to observe a particular section of the waveform closely. Zooming is not possible if the number of displayed points on the screen is less than or equal to 50. The zoom position can be set in units of divisions of the grid.

Zoomed waveforms of up to two locations can be displayed simultaneously (dual zoom). Below are the combinations of the normal waveform and zoomed waveform displays when the normal waveform display frame is denoted as Main and the two zoom waveform display frames are denoted as Z1 and Z2.

<Main>		<Main>		<Z1>	<Z1>
<Z1>	<Z2>	<Z1> or <Z2>		<Z2>	or <Z2>

When displaying Main (main waveform) and Z1 or Z2 (zoomed waveform) simultaneously, a zoom box indicating the zoom position is displayed within the main waveform display frame. The center of the zoom area corresponds to the center of the zoom box. For a display example, see “Display Example When Displaying Zoom Waveforms” in section 1.3.

X-Y Waveform Display <For the setup procedure, see section 8.5>

The relationship between the levels of two input signals can be observed by taking the level of the waveform assigned to the X-axis (horizontal axis) and the level of another waveform (whose display is turned ON) assigned to the Y-axis (vertical axis). Simultaneous observation of X-Y waveforms and normal T-Y waveforms (waveform display using time axis and level) is possible. You can use the X-Y waveform display function to measure the phase angle between two sine wave signals. For example, the waveform that appears when two sine waveforms are shown on the X-Y display is called a Lissajous waveform. From this waveform, the phase angle can be obtained. For a display example, see “Display Example When Displaying X-Y Waveforms” in section 1.3.

Lissajous waveform

Phase angle 0°			
Phase angle 45°			
Phase angle 90°			
Frequency ratio (X:Y)	1:1	1:2	1:3

Snapshot and Clear Trace <For the setup procedure, see section 8.6>

Snapshot

When the trigger mode is set to a mode other than Single or Single (N), the displayed waveforms are periodically updated or displayed in roll mode. By using the snapshot function, you can temporarily hold the waveform (snapshot waveform) that would be cleared when the screen is updated on the screen. The snapshot waveform is displayed in white, allowing for easy comparison against the updated waveform. The snapshot waveform is a screen image waveform. You can save, load, and print the screen image data, but cursor measurements, automated measurement of waveform parameters, zoom, and computation cannot be performed on it.

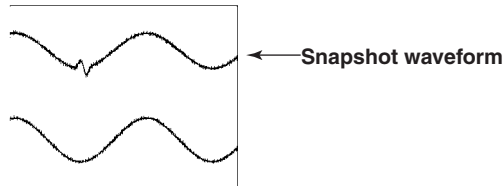

Clear Trace

You can clear the snapshot waveform and restart averaging and accumulation using one key operation. Pressing the SHIFT key followed by the SNAP SHOT key clears only the snapshot waveforms.

Setting Other Waveform Display Items (Graticule, Scale Value, Waveform Label, and Translucent)

Graticule <For the setup procedure, see section 8.7>

You can change the type of graticule that is displayed to suit your needs. For example, you can show a grid on the screen or show only the frame.

Displaying Scale Values <For the setup procedure, see section 8.8>

The upper and lower limits (scale values) of the vertical and horizontal axis of each waveform can be displayed. For a display example, see "Normal Display Screen" in section 1.3.

Displaying Waveform Labels <For the setup procedure, see section 8.9>

A waveform label using up to 8 arbitrary characters can be assigned to each waveform and displayed. For a display example, see "Normal Display Screen" in section 1.3.

Translucent Display <For the setup procedure, see section 8.10>

The dialog boxes that appear during setup operation become translucent allowing the contents underneath the dialog boxes to be seen.

2.5 Waveform Computation

Addition, Subtraction, and Multiplication <For the setup procedure, see section 9.2>

Addition, subtraction, and multiplication can be performed between waveforms of CH1 and CH1 to CH4; CH2 and CH1 to CH4; CH3 and CH1 to CH4 or Math1; and CH4 and CH1 to CH4 or Math1. The computed result becomes the Math1 or Math2 waveform (computed waveform). Addition (+) and subtraction (–) are useful functions when comparing waveforms against a standard signal, checking the signal logic, or comparing the phase. Multiplication (×) is a useful function when applying a voltage signal and a current signal and checking the power waveform.

Binary Computation <For the setup procedure, see section 9.3>

The selected waveform can be converted to a digital waveform of 0s and 1s with respect to the specified threshold level. This computation can be performed on the waveforms of CH1 to CH4 and Math1.

Inversion <For the setup procedure, see section 9.4>

Waveforms can be displayed with the vertical axis inverted by multiplying the measured waveform data by –1. This computation can be performed on the waveforms of CH1 to CH4 and Math1.

Differentiation and Integration <For the setup procedure, see section 9.5>

Differentiates or integrates the waveform of the selected channel. This computation can be performed on the waveforms of CH1 to CH4 and Math1.

Phase Shift <For the setup procedure, see section 9.8>

The phase of the waveform of CH1 to CH4 on the DL7440 and CH1 to CH8 on the DL7480 can be shifted and displayed. The phase shifted waveform is used in the computation (computed waveform).

Scaling the Computed Waveform <For the setup procedure, see section 9.2>

Normally, auto scaling is performed when computed waveforms are displayed. However, you can also select manual scaling. When auto scaling is used, the vertical center line level¹ and sensitivity² of the display frame are automatically determined from the computed waveform, and the computed waveform is displayed. When manual scaling is used, you can set the center and sensitivity as necessary.

¹ Voltage in the case of voltage waveforms.

² Voltage per division in the case of voltage waveforms.

Power Spectrum Computation <For the setup procedure, see section 9.6>

The power spectrum of the input signal can be computed and displayed by taking the FFT (Fast Fourier Transform). This is useful when you wish to check the frequency distribution of the input signal.

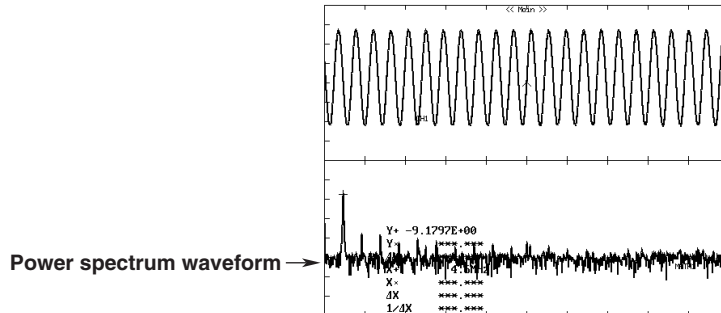

You can select the time window from Rectangular, Hanning, and Flattop. The rectangular window is best suited to transient signals, such as impulse waves, which attenuate completely within the time window. The Hanning and flattop windows allow continuity of the signal by gradually attenuating the parts of the signal located near the ends of the time window down to the 0 level. Hence, it is best suited to continuous signals. With the Hanning window, the frequency resolution is high compared to the flattop window. However, the flattop window has a higher level of accuracy. When the waveform being analyzed is a continuous signal, select the proper window for the application. FFT is performed on 1000, or 10000 points of measured data. The data is converted to half the specified number of points and displayed.

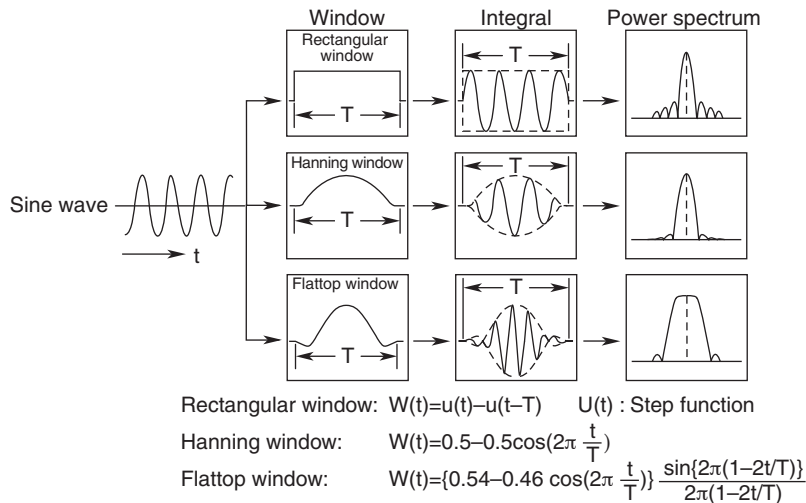

FFT Function

Given that the complex function resulting after the FFT is $G = R + jI$, the power spectrum can be expressed as follows:

DC component	AC component
$10 \log(R^2 + I^2)$	$10 \log\left(\frac{R^2 + I^2}{2}\right)$

R: Real Part, I: Imaginary Part

Reference value (0 dB) of the logarithmic magnitude (Log mag): 1 Vrms²

User-Defined Computation (Optional) <For the setup procedure, see section 9.9>

You can define computing equations by combining the following operators:

+, -, *, /, ABS (absolute value), SQRT (square root), LOG (logarithm), EXP (exponent), NEG (negation), SIN (sine), COS (cosine), TAN (tangent), ATAN(arc tangent), PH (phase), DIF (differentiation), DDIF(2nd order differentiation), INTG (integration), IINTG(double integration), BIN (binary computation), P2 (square), P3 (cube), F1($\sqrt{|C1^2 + C2^2|}$), F2($\sqrt{|C1^2 - C2^2|}$), FV (inverse of the pulse width PHWW), PWHH (pulse width), PWHL (pulse width), PWLH (pulse width), PWLL (pulse width), PWXX(pulse width), DUTYH(duty ratio), DUTYL(duty ratio), FILT1 (digital filter), FILT2 (digital filter), HLBT (Hilbert function), MEAN (moving average), LS- (linear spectrum), PS- (power spectrum), PSD- (power spectrum density), CS- (cross spectrum), TF- (transfer function), CH- (coherence function), variable (T), and constants (K1 to K8).

In addition, you can perform one type of peak computation and the following three types of averaging on the computed data.

Simple Average

The number of average counts are summed linearly (the number of acquisitions, 2 to 128, 2^n steps) and divided by the average count. The resultant waveform is displayed. For details on the equation, see "Averaging Mode" in section 2.4.

Exponential Average

The average is determined by attenuating the effects of past data according to the specified attenuation constant (2 to 256, in 2^n steps). The resultant waveform is displayed. For details on the equation, see "Averaging Mode" in section 2.4.

Cycle Average

Divides one period of computed data into the specified number of data points (Cycle Count). This is done across multiple periods of data from the start to the end position of the computation. Then, the average of the data points at the same position across multiple periods is determined. The resulting waveform is displayed. The following figure shows the result of the cycle average when Cycle Count is set to 720.

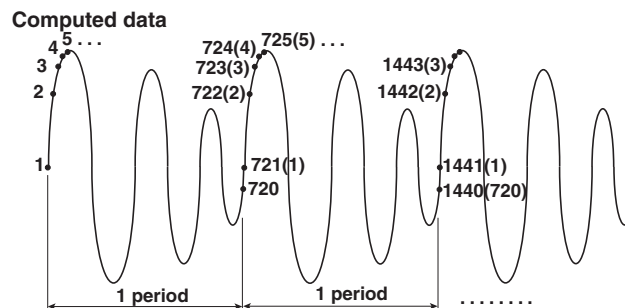
**Result of cycle average**

Determines the simple average of the computed data at the same position across multiple periods and displays the waveform.

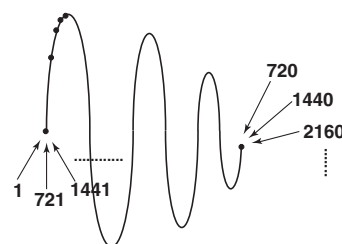

2.5 Waveform Computation

Peak Computation

Determines the maximum value at each point of the computed data and displays the waveform. For every computation, the new computed value is compared to the past value and the larger one is displayed.

3 sets of FFT data

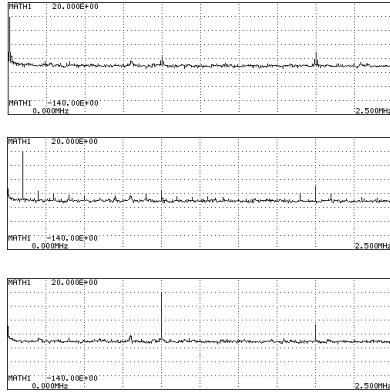

Displays the maximum value of each point

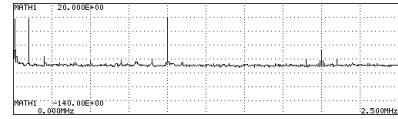

2.6 Analyzing and Searching Waveforms

Displaying History Waveforms <For the setup procedure, see section 10.1>

Past waveform data (history waveforms) stored in the acquisition memory can be displayed when waveform acquisition is stopped. You can display a specified history waveform from the data (up to 4096 waveforms, or the number of triggers) stored in the acquisition memory. The number of waveforms N that can be acquired and held as history waveforms varies from 1 to 4096 depending on the record length and interleave mode settings. The waveform currently displayed on the screen (newest waveform) is counted as the 1st waveform, and up to N-1 waveforms in the past can be displayed.

History Search

You can search history waveforms that meet specified conditions when waveform acquisition is stopped.

Zone Search <For the setup procedure, see section 10.2>

You can search history waveforms that pass or do not pass a specified search zone.

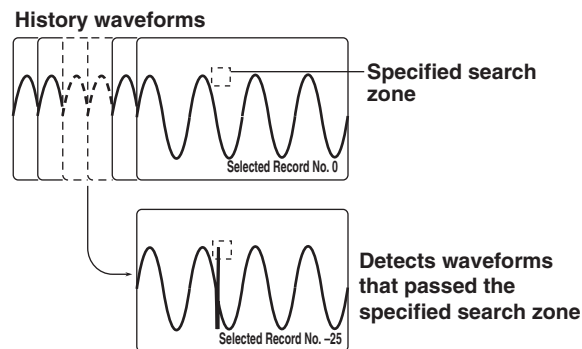

Waveform Parameter Search <For the setup procedure, see section 10.3>

You can search history waveforms that meet or do not meet the specified search parameter conditions.

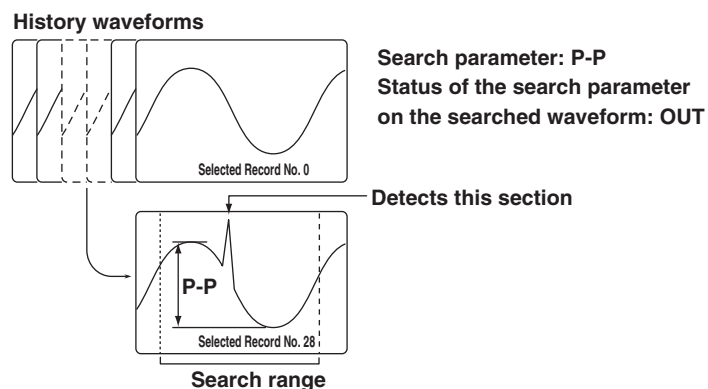

Search & Zoom

When waveform acquisition is stopped, you can search the displayed waveforms (within the display record length. See appendix 1.) and display the waveforms that match the search conditions expanded on the screen.

Edge Search <For the setup procedure, see section 10.4>

Search is performed by counting the number of times the waveform goes above or below (rising or falling) a specified level.

Search condition Edge: rising edge and detection count: 2

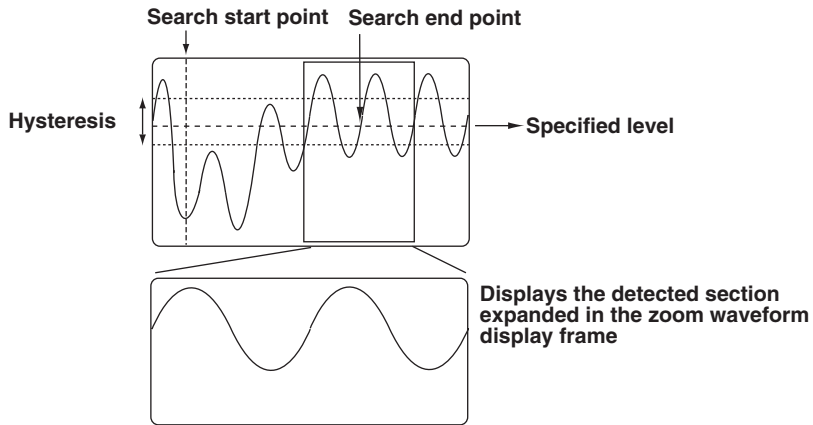

Serial Pattern Search <For the setup procedure, see section 10.4>

Search is performed on whether the serial status pattern of the waveform (status pattern of the waveform that changes over time) is the same as the status pattern set in advance. You can also set whether the timing used to detect the waveform status (up to 64 statuses) is synchronized to a selected clock signal or is performed at certain time intervals.

Condition Clock channel: CH1, slope on which to check the status: rising, and searched waveform: CH2

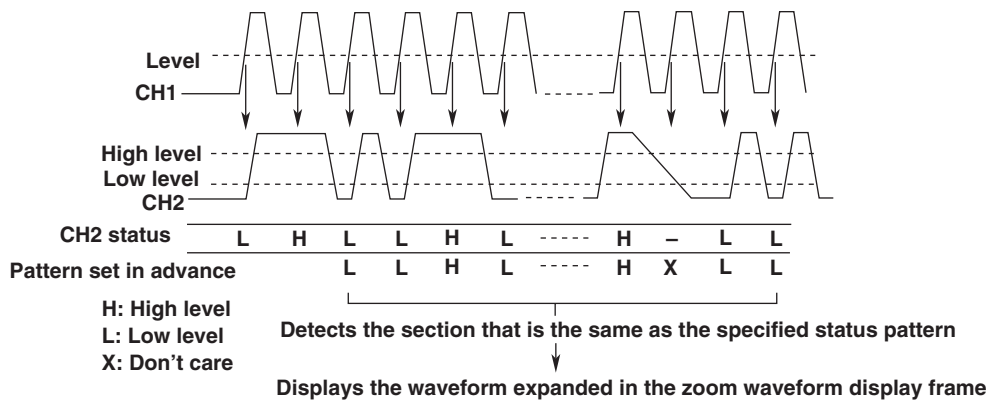

Parallel Pattern Search <For the setup procedure, see section 10.4>

Search is performed on whether the parallel status pattern of the waveforms (status pattern of the waveforms at the same point) is the same as the status pattern set in advance. You can also set whether the waveform status is detected in sync with the selected clock signal and whether statuses of all waveforms are detected.

Condition Clock channel: None, CH1: L, CH2: L, CH3: H, CH4:L, Math1: X, Math2: X, and CH5 to CH8: X on the DL7480

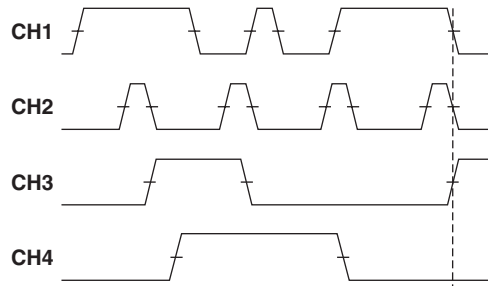

CH1	L	H	L	H	L	H	L
CH2	L	H	L	H	L	H	L
CH3	L	H	L	H	L	H	L
CH4	L	H	L	H	L	H	L

H: High level
L: Low level
X: Don't care

↑ Detects this position and displays the waveform expanded in the zoom waveform display frame

Condition Clock channel: CH1, falling slope, CH2: L, CH3: H, and CH4: L

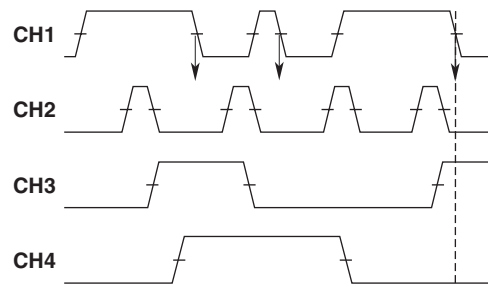

CH2	L	H	L	H	L	H	L
CH3	L	H	L	H	L	H	L
CH4	L	H	L	H	L	H	L

H: High level
L: Low level

↑ Detects this position and displays the waveform expanded in the zoom waveform display frame

2.6 Analyzing and Searching Waveforms

Pulse Width Search <For the setup procedure, see section 10.4>

Search is performed on whether the pulse width of the waveform above or below a specified level is shorter or longer than the specified determination time.

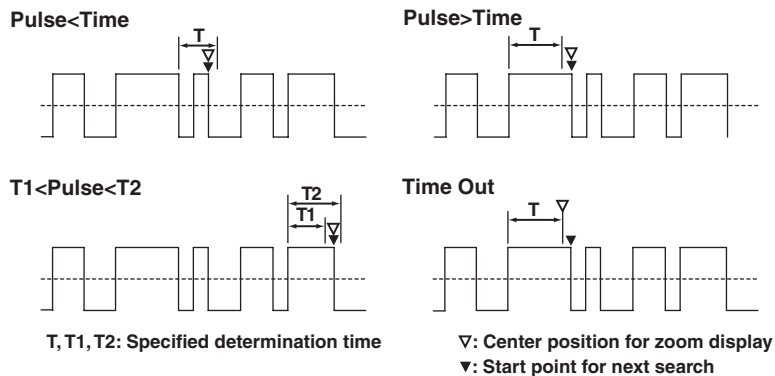

Auto Scroll Search <For the setup procedure, see section 10.4>

The zoom position automatically moves (auto scroll) in the specified direction. You can confirm the zoomed waveform and stop the scroll operation at an arbitrary position.

Analyzing and Searching SPI Signals <For the setup procedure, see section 10.11>

SPI (Serial Peripheral Interface) is a serial interface proposed by Motorola. Data transmission is carried out using three signal wires, a clock signal, output data, and input data. By adding a chip select signal (CS), a master device can control the data output of a slave device. Data is transmitted in units of bytes (8 bits) by synchronizing to the clock signal. The DL7400 can analyze and search the SPI signal at the byte level.

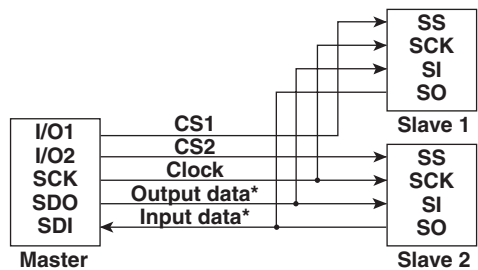

* Input/Output as viewed from master.

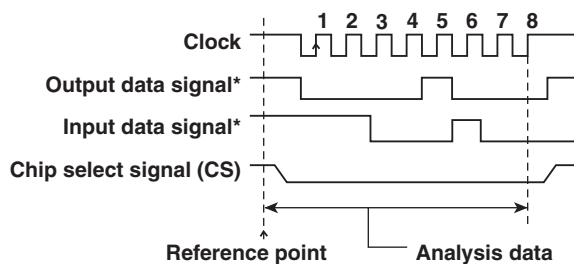

* Input/Output as viewed from master.

Analysis data
 Analysis number: 0
 Output data signal*: 08
 Input data signal*: C4
 Chip select signal: L (low level)

Cursor Measurements <For the setup procedure, see section 10.5>

Cursors can be placed on the displayed waveform (within the display record length. See appendix 1) and various types of measured values at the cross point of the cursor and waveform can be displayed. Four types of cursors are available.

Horizontal Cursors

Two broken lines (horizontal cursors) are displayed on the horizontal axis (X-axis). The Y-axis values at the cursor positions can be measured. The level difference between cursors can also be measured.

Vertical Cursors

Two broken lines (vertical cursors) are displayed on the vertical axis (Y-axis). The time (X-axis values) from the trigger point to each vertical cursor and the time difference between the vertical cursors can be measured. In addition, the signal level (Y-axis value) at each cursor position and the level difference between the cursors can be measured.

Marker Cursors

Four markers are displayed on the selected waveform. The level (Y-axis value) at each marker, the time (X-axis value) from the trigger position, and the level difference and time difference between markers can be measured.

Angle Cursors

Measurements can be made by converting the time axis values into angles. The zero point (position of reference cursor Ref1) and the end point (position of the reference cursor Ref2) are set on the X-axis and an angle (reference angle) is assigned to the width of Ref1 and Ref2. The positions of the two angle cursors (Cursor1 and Cursor2) can be converted into angles from the specified reference angle and measured.

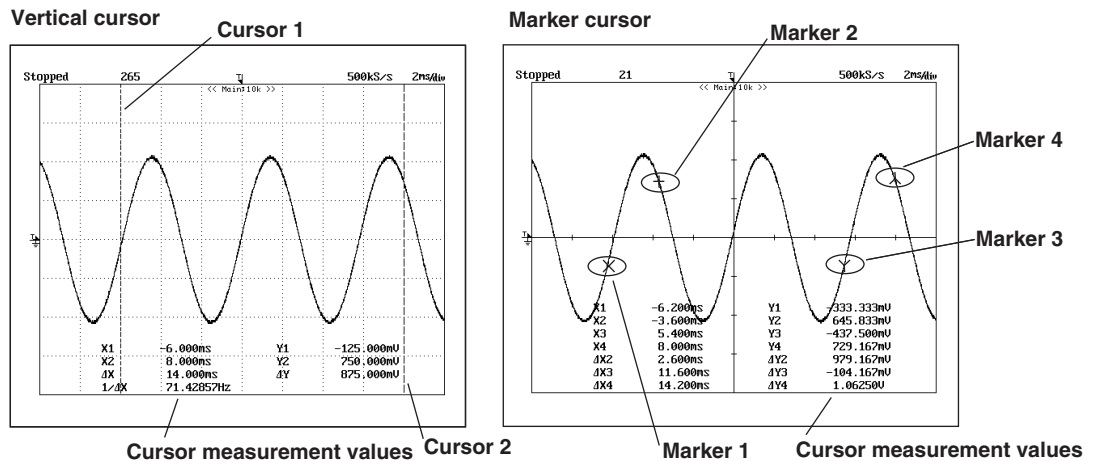

Automated Measurement of Waveform Parameters

Automated Measurement of Waveform Parameters <For the setup procedure, see section 10.6>

Automated measurement can be performed on various measurement parameters on the displayed waveform (within the display record length, see appendix 1). Up to 24000 values of the results of automated measurements can be saved to a file (see section 12.10). There are 27 types of measurement parameters (including the delay between waveforms). Up to 12 parameters from the selected parameters of all the channels can be displayed.

Statistical Processing <For the setup procedure, see section 10.7>

Statistical processing can be performed on the automated measurement values described above. The following five statistics can be determined on the two measured values of automated measurement parameters.

- Maximum value (Max)
- Minimum value (Min)
- Average value (Avg)
- Standard deviation (Sdv)
- Number of measured values used in the statistical processing (Cnt)

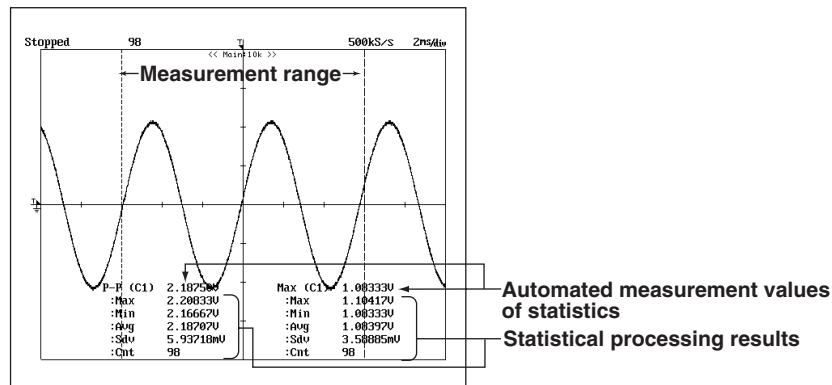

The following three statistical processing methods are available.

- **Normal Statistical Processing**
 Statistical processing is performed on all acquired waveforms that are displayed while acquiring waveforms.
- **Measurement per Cycle and Statistical Processing within the Measurement Range**
 The cycle of the displayed waveform is determined in order from the oldest data, the selected parameters for automated measurement are measured on the data within the cycle, and statistical processing is performed. The cycle is determined in the same fashion as the Period for the waveform parameter. You can select whether to apply the cycle of the specified waveform to all waveforms (CH1 to CH8 (4), Math1, and Math2) or determine the cycle for each waveform (Own).
 Measurement and statistical processing can also be performed on a single displayed history waveform. Statistical processing is performed from the oldest data of the displayed waveform in blocks of cycles.

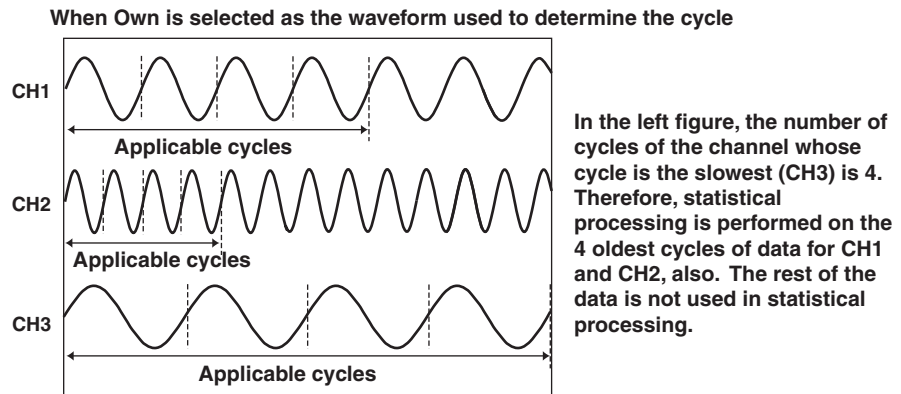

- **Statistical Processing of History Waveforms**

Automated measurement is performed on the history waveforms in the selected range and statistical processing is performed. Statistical processing is performed starting with the oldest data.

Automated Measurement of Waveform Parameters on Dual Areas <For the setup procedure, see section 10.8>

You can specify two areas and perform automated measurement of waveform parameters on each area. You can also perform computation on the parameters determined in the two areas. Measurement per cycle and statistical processing within the measurement range are not possible.

GO/NO-GO Determination <For the setup procedure, see section 10.9 and 10.10>

The GO/NO-GO function is useful when you want to inspect signals and track down abnormal symptoms on a production line making electronic equipment. The function determines whether the waveform is within the preset range and performs a predetermined action when the decision is GO or NO-GO. There are two methods in making the determination: a method in which a waveform zone is set on the screen and a method in which a waveform parameter range is specified.

The actions that can be performed when the decision is GO or NO-GO are sounding of the buzzer, saving of the data, printing of the screen image data, and transmission of e-mail messages (when the Ethernet interface option is installed).

2.7 Communication

Communication Using Commands (GP-IB, USB, or Ethernet) <For the setup procedure, see the Communication Interface User's Manual CD-ROM>

The DL7400 comes standard with a GP-IB and a USB interface. An Ethernet interface is available as an option. Using communication commands, you can output waveform data to a PC for data analysis or control the DL7400 using an external controller to carry out waveform measurements.

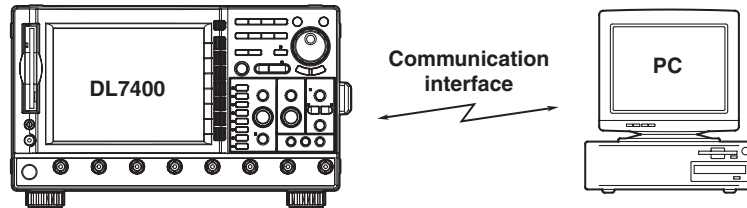

Saving and Loading Data from a Network Drive (FTP Client) <For the setup procedure, see section 13.3>

As with the built-in storage medium and external SCSI devices, waveform and setup data can be saved and loaded and screen image data can be saved to an FTP server* on the network.

* PC or workstation on which the FTP server function is running.

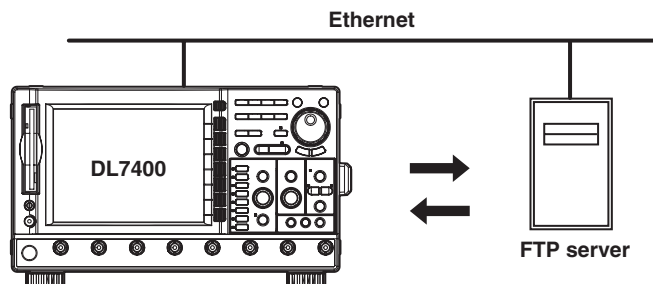

Printing on a Network Printer (LPR Client) <For the setup procedure, see section 13.4>

The screen image can be printed on a network printer in the same way as the built-in printer (optional) or USB printer.

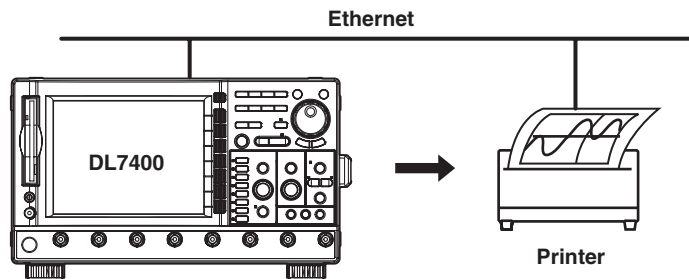

Transmitting E-Mails <For the setup procedure, see section 13.5>

Information from the DL7400 can be transmitted periodically in an e-mail message to a specified mail address. You can also transmit information such as the trigger time in an e-mail message as an action for the GO/NO-GO determination or action-on-trigger.

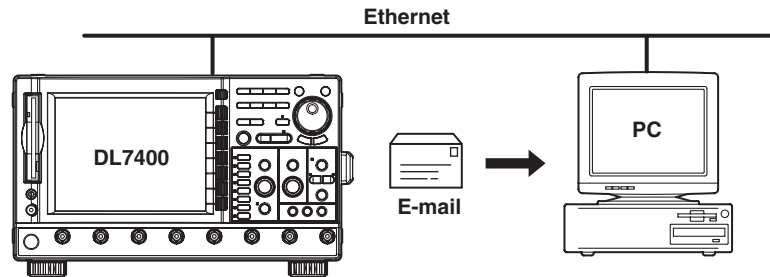
**Accessing the DL7400 from a PC or Workstation (FTP Server) <For the setup procedure, see section 13.6>**

The DL7400 can be accessed from an FTP client on the network, and the files on the built-in storage medium of the DL7400 or external SCSI device can be retrieved.

* PC or workstation on which the FTP client function is running.

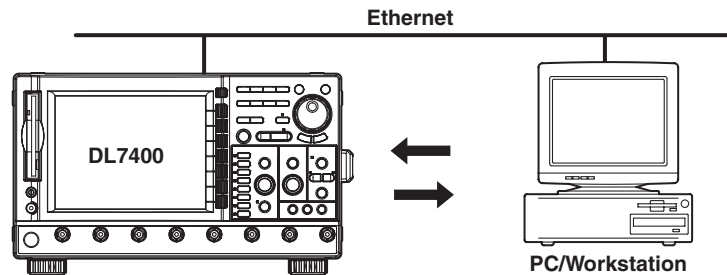
**Web Server <For the setup procedure, see section 13.7>**

The DL7400 can function as a Web server. By displaying the Web page of the DL7400, file transfer, monitoring of displayed waveforms, basic DL7400 setup operation, and the retrieval operation of waveform data are possible.

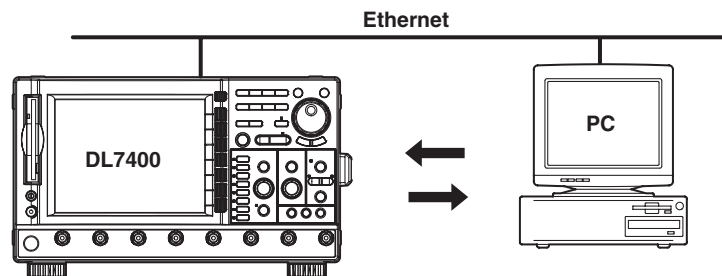

2.8 Other Useful Functions

Entering Values and Text Using the USB Keyboard <For the setup procedure, see section 4.3>

You can connect a USB keyboard and enter file names and comments. In addition, the functions of each key on the front panel of the DL7400 are assigned to the keys on the keyboard. Thus, the keyboard can be used to carry out operations that are the same as the key operations on the DL7400. For the key assignments, see appendix 6.

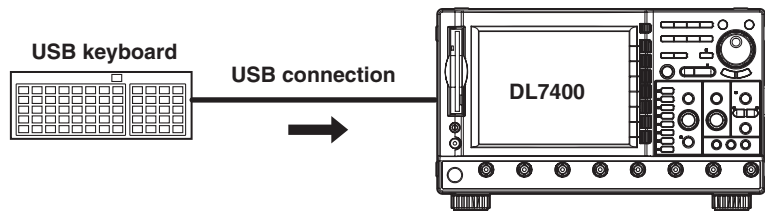

Operating the DL7400 Using a USB Mouse <For the setup procedure, see section 4.3>

You can use a USB mouse to operate the DL7400 as you would using the front panel keys. In addition, you can point to a desired item on a menu and click the item. This is analogous to pressing a soft key corresponding to a menu and pressing the SELECT key.

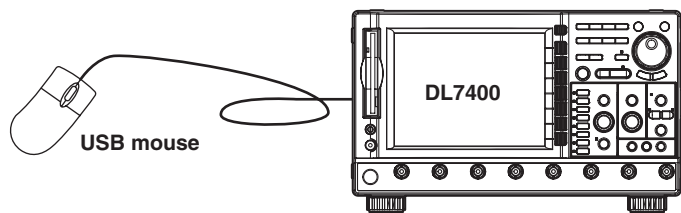

Initialization <For the setup procedure, see section 4.4>

You can use the Initialize key to restore the defaults of the settings entered using panel keys. However, some of the settings are not initialized (see section 4.4). To initialize all settings excluding the date/time setting (display ON/OFF is initialized) to their factory defaults, turn ON the power while holding down the RESET key. Release the RESET key after a beep is heard.

Auto Setup <For the setup procedure, see section 4.5>

This function automatically sets the voltage axis, time axis, trigger settings, and other settings to suit the input signal. This is useful when the characteristics of the input signal are unknown. However, the auto setup function may not work depending on the input signal.

Preset <For the setup procedure, see section 5.7>

This function sets the V/div, input coupling, trigger level, and other settings to values that are suitable for CMOS and ECL signals (or arbitrary settings). You can also automatically set to the optimum values for the current probes 700937 and 701930 (sold separately).

Printing Screen Images <For the setup procedure, see chapter 11>

Screen images can be printed on the built-in printer (option), USB printer, or network printer (when the Ethernet interface option is installed).

Saving and Loading Data from the Storage Medium <For the setup procedure, see chapter 12>

The DL740 allows various data to be stored to and loaded from the following storage media.

- Floppy disk or Zip disk (selected at the time of purchase)
- PC card (comes standard)
- External SCSI device (MO disk drive, hard disk drive, etc. When the SCSI interface option is installed)
- External USB storage (MO disk drive, hard disk drive, and flash memory)
- Network drive (when the Ethernet interface option is installed)

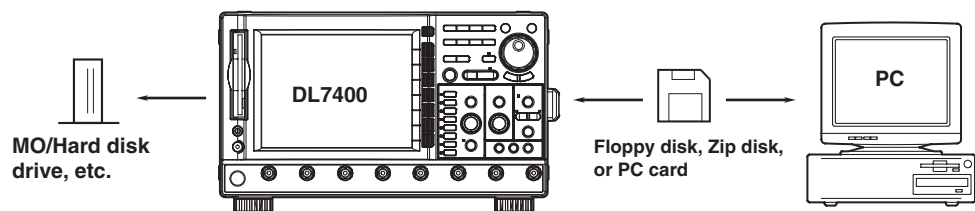
**Saving and Loading Setup Data, Waveform Data, and Snapshot Waveforms <For the setup procedure, see sections 12.7, 12.8, and 12.9>**

The setup data, waveform data, and snapshot waveforms can be saved to or loaded from a selected storage medium.

Saving Screen Image Data and Displaying the Thumbnails of the Stored Screen Image Data <For the setup procedure, see sections 12.12 and 12.13>

The screen image data can be stored to a selected storage medium. The data can be stored in TIFF, BMP, PostScript, PNG, and JPEG formats allowing the data to be pasted on a document created with a DTP application. In addition, the thumbnails (reduced and simplified images) of the screen image data saved to the storage medium can be displayed on the DL740 screen. This feature is useful for checking the contents of the stored screen image data.

Saving Automated Measurement Values of Waveform Parameters and Detailed Analysis List of SPI Signals

The automated measurement values of waveform parameters and the detailed analysis list of SPI signals can be saved to a selected storage medium.

Operating the DL740 Using a Free Software Program

The DL740 can be controlled from a PC using Wirepuller, a free software program, when connected via the GP-IB, USB, or Ethernet interface. The software program can be downloaded from the following Web pages.

- English version: <http://www.yokogawa.com/tm/Bu/software.htm>
- Japanese version: <http://www.yokogawa.co.jp/Measurement/F-SOFT/>

3.1 Handling Precautions

Safety Precautions

If you are using this instrument for the first time, make sure to thoroughly read the safety precautions given on page v.

Do Not Remove the Case

Do not remove the case from the instrument. Some sections inside the instrument have high voltages and are extremely dangerous. For internal inspection or adjustment, contact your nearest YOKOGAWA dealer.

Unplug If Abnormal Behavior Occurs

If you notice smoke or unusual odors coming from the instrument, immediately turn OFF the power and unplug the power cord. If such an irregularity occurs, contact your YOKOGAWA dealer.

Do Not Damage the Power Cord

Nothing should be placed on the power cord. The cord should be kept away from any heat sources. When unplugging the power cord from the outlet, never pull by the cord itself. Always hold and pull by the plug. If the power cord is damaged, contact your dealer for replacement. Refer to page iii for the part number when placing an order.

General Handling Precautions

Do Not Place Objects on Top of the Instrument

Never place other instruments or objects containing water on top of the instrument, otherwise a breakdown may occur.

Do Not Apply Shock to the Input Section

Vibration or shock to the input connectors or probes may turn into electrical noise and enter the instrument via the signal lines.

Do Not Damage the LCD

Since the LCD screen is very vulnerable and can be easily scratched, do not allow any sharp objects near it. Also it should not be exposed to vibrations and shocks.

Unplug during Extended Non-Use

Unplug the power cord from the outlet.

3.1 Handling Precautions

When Carrying the Instrument

Remove the power cord and connecting cables. Always carry the instrument by the handle on the right side as you face the instrument (as shown below), or carry it with both hands.

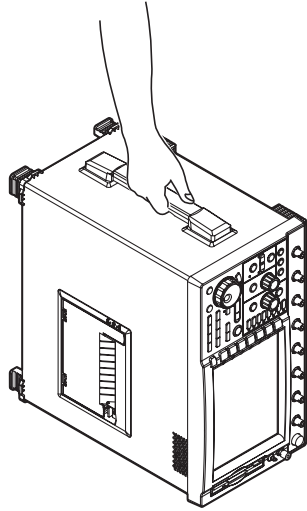

Cleaning

When cleaning the case or the operation panel, first remove the power cord from the AC outlet. Then, wipe with a dry, soft, clean cloth. Do not use volatile chemicals since this might cause discoloring and deformation.

3.2 Installing the Instrument



WARNING

To avoid danger, never use the instrument with the rear panel facing down, as the cooling vents will be obstructed.

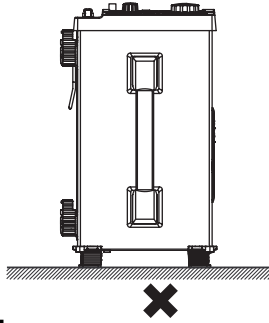

Installation Conditions

Install the instrument in a place that meets the following conditions.

Flat, Even Surface

Install the instrument with the correct orientation on a stable, horizontal surface. The recording quality of the printer (optional) may be hindered when the instrument is used in an unstable place.

Well-Ventilated Location

Inlet holes are located on the top and bottom of the instrument. In addition, there are exhaust holes for the cooling fan on the rear panel. To prevent internal overheating, allow for enough space around the instrument (see the figure below) and do not block the inlet and exhaust holes. If a printer comes with your DL7400, allow extra space for operation and do not place objects on top of the printer.

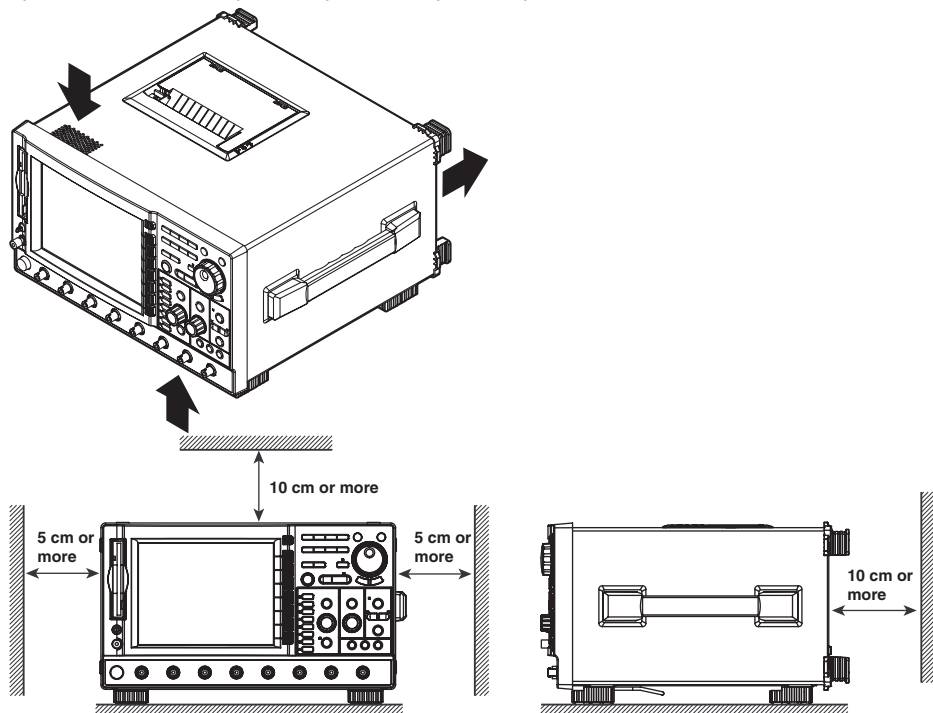

3.2 Installing the Instrument

Ambient Temperature and Humidity

Ambient temperature	5 to 40°C
Ambient humidity	20 to 80% RH (when the printer is not used) 35 to 80% RH (when using the printer) In either case, no condensation should be present.

Note

- To ensure high measurement accuracy, operate the instrument in the $23 \pm 5^\circ\text{C}$ temperature range and $55 \pm 10\%$ RH.
 - Condensation may occur if the instrument is moved to another place where the ambient temperature is higher, or if the temperature changes rapidly. In such cases, allow the instrument adjust to the new environment for at least an hour before using the instrument.
-

Do not install the instrument in the following places.

- In direct sunlight or near heat sources.
- Where an excessive amount of soot, steam, dust, or corrosive gas is present.
- Near strong magnetic field sources.
- Near high voltage equipment or power lines.
- Where the level of mechanical vibration is high.
- On an unstable surface.

Installation Position

Place the instrument in a horizontal position or inclined position using the stand (see the figure below). When using the stand, pull it forward until it locks. To retract it, set the stand back to its original position.

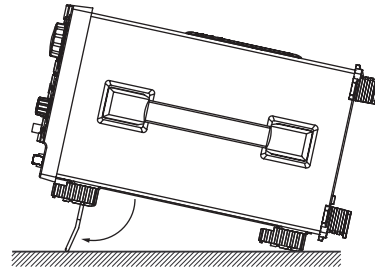
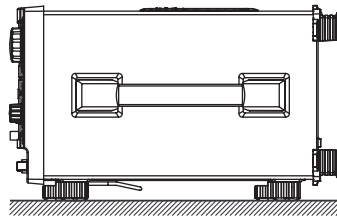

Rubber Feet

If the instrument is installed in a tilted position as shown in the figure above, rubber stoppers can be attached to the feet to prevent the instrument from sliding. Four rubber feet are included in the package.

3.3 Connecting the Power Supply and Turning ON/OFF the Power Switch

Before Connecting the Power

Make sure that you observe the following points before connecting the power. Failure to do so may cause electric shock or damage to the instrument.



WARNING

- Before connecting the power cord, ensure that the source voltage matches the rated supply voltage of the instrument and that it is within the maximum rated voltage of the provided power cord.
- Connect the power cord after checking that the power switch of the instrument is turned OFF.
- To prevent the possibility of electric shock or fire, be sure to use the power cord for the instrument that was supplied by YOKOGAWA.
- Make sure to perform protective earth grounding to prevent electric shock. Connect the power cord to a three-prong power outlet with a protective earth terminal.
- Do not use an extension cord without protective earth ground. Otherwise, the protection function will be compromised.
- Use an AC outlet that complies with the power cord provided and securely connect the protective grounding. If such an AC outlet is unavailable and protective grounding cannot be furnished, do not use the instrument.

Connecting the Power Cord

1. Check that the power switch is turned OFF.
2. Connect the power cord plug to the power connector on the rear panel. Use the power cord that came with the package.
3. Connect the other end of the cord to an outlet that meets the conditions below. The AC outlet must be of a three-prong type with a protective earth ground terminal.

Rated supply voltage*	100 to 120 VAC/220 to 240 VAC
Permitted supply voltage range	90 to 132 VAC/198 to 264 VAC
Rated supply voltage frequency	50/60 Hz
Permitted supply voltage frequency range	48 to 63 Hz
Maximum power consumption (when using the printer)	320 VA

* The DL7400 can use a 100-V or a 200-V system for the power supply. Check that the voltage supplied to the DL7400 is less than or equal to the maximum rated voltage of the provided power cord (see page ii) before using it.

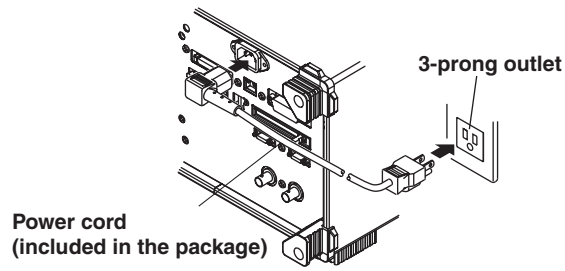

Turning ON/OFF the Power Switch



CAUTION

If you turn ON/OFF the DL7400 while a Zip disk is inserted in the drive, the Zip drive may malfunction. Remove the Zip disk from the drive before turning ON/OFF the DL7400.

Items to Be Checked before Turning ON the Power

The instrument is properly installed.

See section 3.2, "Installing the Instrument" (page 3-3).

The power cord is properly connected.

See section 3.3, "Connecting the Power Supply and Turning ON/OFF the Power Switch" (page 3-5).

Turning ON/OFF the Power Switch

The power switch is located in the lower left corner of the front panel. The power switch is a push button. Press once to turn it "ON" and press again to turn it "OFF."

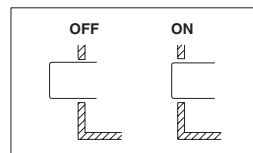
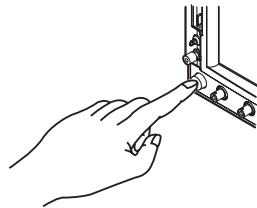

Power Up Operation

Self-test and calibration start automatically when the power switch is turned ON. If the check results are satisfactory, the normal waveform display screen will appear.

Note

- Allow at least 10 s when turning ON the power switch after turning it OFF.
- If self-test and calibration do not start when the power is turned ON, or if the normal waveform display screen does not appear, turn OFF the power switch and check the following points.
 - That the power cord is plugged in properly.
 - That the correct voltage is coming to the power outlet (see page 3-5).
 - That when the power is turned ON while holding down the RESET key, all settings excluding the date/time setting (display ON/OFF is initialized) are initialized to their factory defaults. For details on the initialization of the settings, see section 4.4.

If the instrument still fails to power up when the power switch is turned ON after checking these points, contact your nearest YOKOGAWA dealer.

Warm Up and Calibration

- To ensure accurate measurements, allow the instrument to warm up for at least 30 minutes after turning ON the power switch.
- After warm-up is complete, perform calibration (see section 4.6).

Power Down Operation

Current settings are stored immediately before the power is turned OFF or when the power cord is unplugged. Therefore, the next time the power is turned ON, the waveforms are displayed using the previous settings.

Note

A lithium battery is used to retain the setup parameters. When the lithium battery voltage falls below a certain level, a message is displayed on the screen (see section 16.2) when the power switch is turned ON. If this happens, you must quickly have the lithium battery replaced. The user cannot replace the battery. For battery replacement, contact your nearest YOKOGAWA dealer. For information regarding battery life, see section 16.5.

3.4 Connecting the Probe

Signal Input Terminal

Connect the probe (or other input cables such as the BNC cable) to any of the input terminals (4 terminals marked as CH1 to CH4 on the DL7440 and 8 terminals marked CH1 to CH8 on the DL7480) at the bottom section of the front panel. The input impedance is $1\text{ M}\Omega \pm 1.0\%$ and approximately 20 pF or $50\ \Omega \pm 1.0\%$.



CAUTION

- The maximum input voltage for 1-M Ω input is 400 V (DC + ACpeak) or 282 Vrms when the frequency is 1 kHz or less. Applying a voltage exceeding either of the two values can damage the input section. If the frequency is above 1 kHz, damage may occur even when the voltage is below the value.
- The maximum input voltage for 50- Ω input is 5 Vrms or 10 Vpeak. Applying a voltage exceeding either of the two values can damage the input section.

DL7440

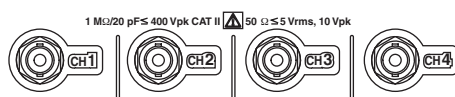

DL7480

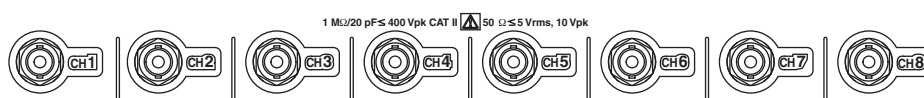

Precautions to Be Taken When Connecting Cables

- When connecting a probe to the instrument for the first time, perform phase correction of the probe as described in section 3.5, “Compensating the Probe (Phase Correction).” Failure to do so will cause unstable gain across different frequencies, thereby preventing correct measurement. Perform the phase correction on each channel to which a probe is to be connected.
- Note that if the object being measured is directly connected to the instrument without using a probe, correct measurements may not be possible due to loading effects.

Probes

Specifications of the Probe (Model 700988) That Comes Standard (after Probe Phase Correction)

Item	Specifications		Condition
	10:1 Attenuation	1:1 Attenuation	
Input resistance/capacity	10 M $\Omega \pm 2\%$, approx. 14 pF	1 M $\Omega \pm 1.0\%$, approx. 150 pF	When used on the DL7400
Attenuation	10:1 $\pm 3\%$	—	When used on the DL7400
Frequency range	DC to 400 MHz	DC to 6 MHz	When used on the DL7400
Rise time	Within 900 ps	Within 58 ns	When used on the DL7400
Maximum input voltage	600 V (DC+ACpeak) or 424 Vrms, at a frequency of 100 kHz or less	*	—
Connector type	BNC	BNC	—
Total length	1.5 m	1.5 m	—

* When using the DL7400 with the attenuation set to 1:1, use the probe at a voltage less than or equal to the maximum input voltage of the DL7400.

3.4 Connecting the Probe

Miniature Passive Probe (701941) Specifications after Probe Phase Correction

(On models with the /EX4 option, 701941 passive probes are provided in place of 700988 passive probes.)

Item	Specifications	Conditions
Input resistance/capacity	10 MΩ ± 2% / approx. 10 pF	When used on the DL7400
Attenuation	10:1 ±3%	When used on the DL7400
Frequency range	DC to 500 MHz	When used on the DL7400
Rise time	Within 700 ps	When used on the DL7400
Maximum input voltage	400 Vrms*	500 kHz or less For the maximum input voltage when 500 kHz is exceeded, see the manual that comes with the probe.
Connector type	BNC	–
Cable length	1.2 m	–

* This probe complies with the following measurement categories of IEC 61010-031.
 Measurement category I 400 Vrms (transient overvoltage: 1250 V)
 Measurement category II 300 Vrms

Precautions to Be Taken When Using Probes Other Than Those Provided with the Instrument

- When measuring a signal containing frequency components near 500 MHz, use a probe with a frequency range of 500 MHz or higher.
- Correct measured values cannot be displayed when using a probe with an attenuation other than 1:1, 10:1, 100:1, and 1000:1.
- For current probes, use 700937, 701930, 701931, 701932, or 701933 by YOKOGAWA.

Setting the Probe Attenuation/Current-to-Voltage Conversion Ratio

Follow the procedures given in section 5.5 and set the attenuation/current-to-voltage conversion ratio of the DL7400 according to the probe attenuation/current-to-voltage conversion ratio. Correct measured values can be displayed only if the setting is correct.

When Using the FET Probe, Current Probe, or Differential Probe

When using FET probes (700939), current probes (700937, 701930, 701931, 701932, or 701933), or differential probes (701920 or 701922) made by YOKOGAWA, use the probe power supply on the rear panel of the DL7400.



CAUTION

Do not use the probe power supply terminals on the rear panel of the DL7400 for purposes other than supplying power to the probes (700939, 700937, 701930, 701931, 701932, 701933, 701920, or 701922). Doing so may damage the DL7400 or the device connected to them.

Precautions to Be Taken When Using the FET Probe, Current Probe, or Differential Probe

When connecting FET probes (700939), current probes (700937, 701930, 701931, 701932, or 701933), or differential probes (701920 or 701922) to the probe power supply terminal on the rear panel, make sure that the current does not exceed the range shown below. Otherwise, the DL7400 operation may become unstable due to the activation of the excessive current protection circuit of the power supply.

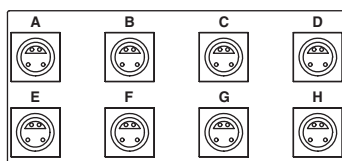

PROBE POWER (±12V DC ⇒)

The following current values must be less than or equal to ±500 mA.

- Total current consumption of A and E
- Total current consumption of B and F
- Total current consumption of C and G
- Total current consumption of D and H (E, F, G, and H correspond to the DL7480 with the /P4 option installed.)

When using the current probe (700937, 701930, 701931, 701932, or 701933), the number of probes that can be used is limited by the current generated by the device under measurement (current measured by the current probe). The characteristics of the measured current versus the current consumption of an active probe that can be connected to the DL7400 are shown below.

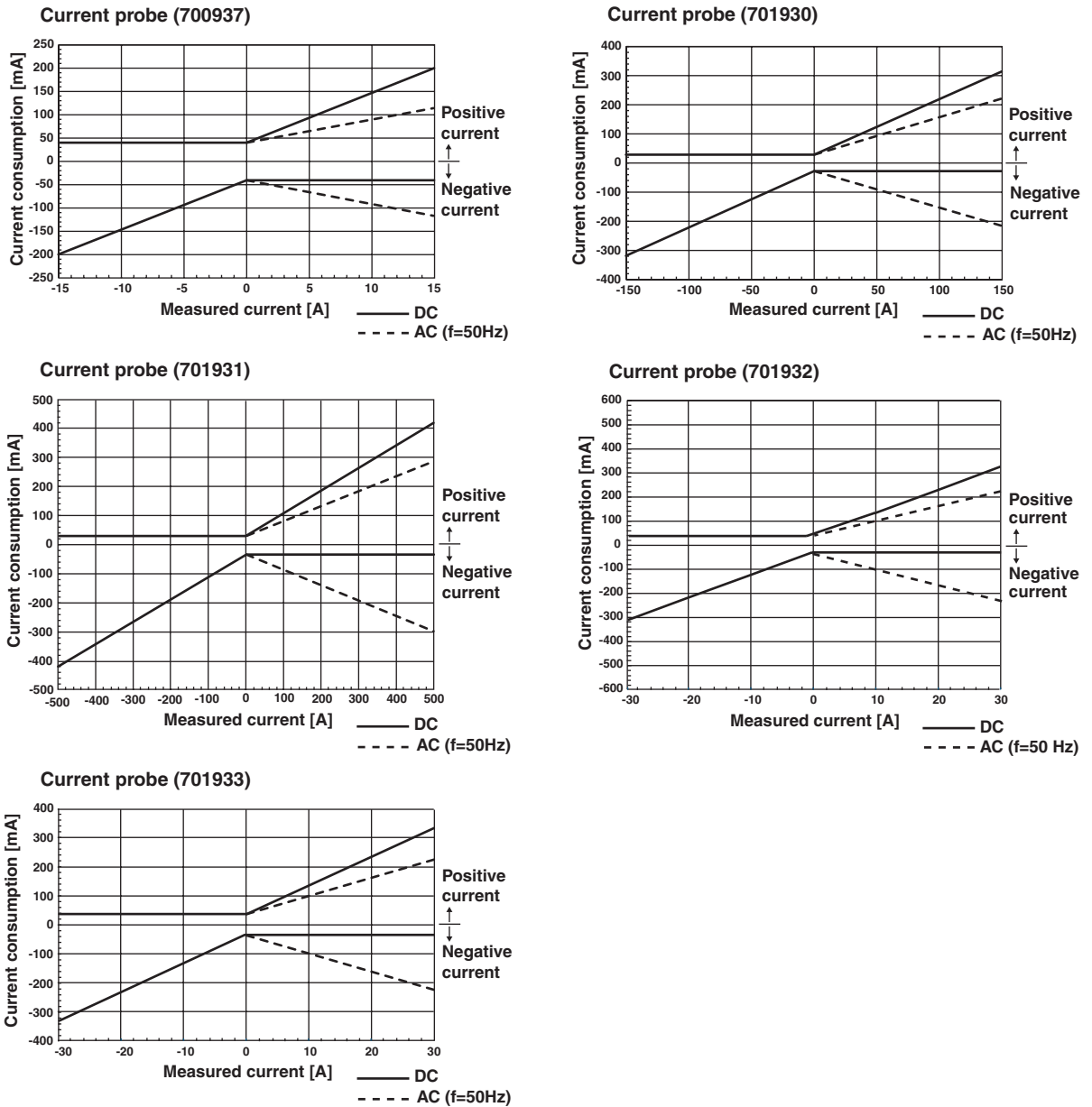

Calculate the consumption current of the FET probe (700939) and the differential probe (701920 or 701921) at 125 mA maximum for both positive and negative polarities.

3.5 Compensating the Probe (Phase Correction)



CAUTION

Do not apply external voltage to the probe compensation signal output terminal. This may cause damage to the internal circuitry.

Procedure

1. Turn ON the power switch.
2. Connect the probe to the input terminal to which the signal is to be applied.
3. Connect the tip of the probe to the probe compensation signal output terminal and the ground wire to the functional ground terminal.
4. Perform auto setup according to the procedures given in section 4.5.
5. Insert a flat-head screwdriver to the phase correction hole and turn the variable capacitor to make the displayed waveform a correct rectangular wave.

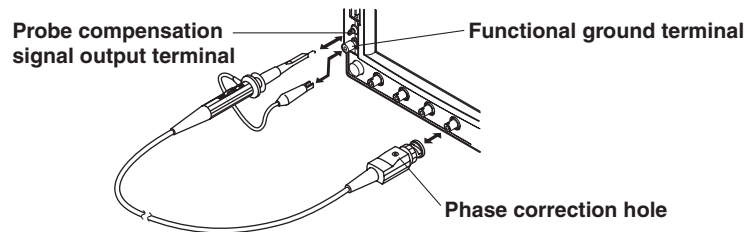

Explanation

Necessity of Phase Correction of the Probe

If the input capacity of the probe is not within the adequate range, the gain across different frequencies will not be uniform. Consequently, waveforms cannot be displayed correctly. In addition, the input capacitance of each probe is not constant. Thus, a variable capacitor (trimmer) is provided for making adjustments. Phase correction refers to the act of adjusting the probe using this capacitor. When using the probe for the first time, make sure to perform phase correction.

Furthermore, the appropriate input capacitance varies depending on the oscilloscope channel. Therefore, probe compensation is also required when the probe is switched from one channel to another.

Probe Compensation Signal

The probe compensation signal output terminal outputs the following rectangular wave signal.

Frequency	Approx. 1 kHz
Amplitude	Approx. 1 V

Differences in the Waveform due to the Phase Correction of the Probe

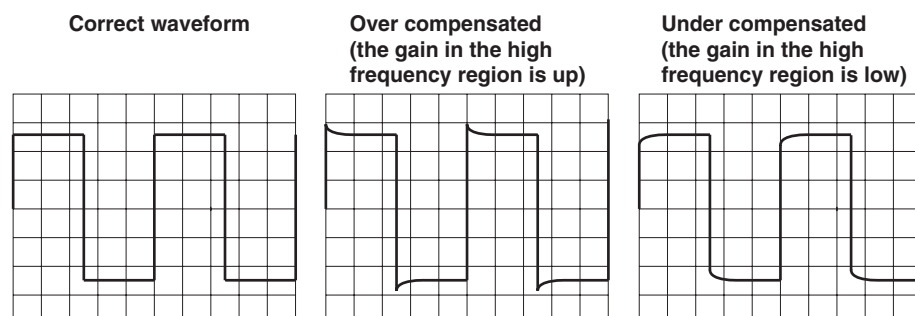

3.6 Connecting Logic Probes (Optional)



CAUTION

- The maximum input voltage of the logic probe input is ± 40 V (DC + ACpeak) or 28 Vrms when the frequency is 1 kHz or less. Applying a voltage exceeding this value may damage the logic probe or the DL7400. If the frequency is above 1 kHz, damage may occur even when the voltage is below this value.
- The 8 input lines on each POD have a common ground. In addition, the ground for the instrument and the ground for each POD are also common. Do not connect inputs which have different common voltages, as doing so may cause damage to the DL7400, logic probe, or other connected instruments.
- Make sure to turn OFF the power to the DL7400 before connecting or disconnecting the 26-pin connector from the DL7400.

Logic Probe Input Connector

Connect the logic probe (701981) to either of the logic probe input connectors (marked A and B) on the rear panel.

- * When interleave mode is turned ON, the logic signal of connector B can be used as a trigger source (see section 2.3), but the signal cannot be acquired. For the setup procedure for interleave mode, see section 7.3.

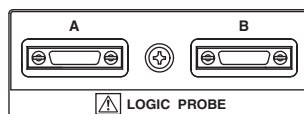

About the Logic Probe

The logic probe (701980/701981) connects to the logic probe input connector of the DL7440/DL7480. When connecting to the measurement point, use the connecting lead (B9852EJ+A1470JZ, A1471JZ) that comes with the probe. Do not alter the connecting leads. Doing so may cause the leads from satisfying the specification.

Each pod (A or B) consists of 8 logic input terminals. You can select the threshold level on the DL7440/DL7480 menu from CMOS (5 V), CMOS (3.3 V), ECL, and user-defined (see section 5.10).

Logic Input Specifications When Used on the DL7400

Item	When using the 701981	When using the 701980 ¹
Maximum toggle frequency ²	250 MHz	100 MHz
Number of inputs	16 (when two logic probes are used)	Same as the 701981
Maximum input voltage ³	± 40 V (DC+ACpeak) or 28 Vrms	Same as the 701981
Input range	± 10 V	± 40 V
Maximum sampling rate	1 GS/s (interleave mode OFF) 2 GS/s (interleave mode ON)	Same as the 701981 Same as the 701981
Threshold level	± 10 V (resolution: 0.1 V)	± 40 V (resolution: 0.1 V)
Threshold accuracy ²	$\pm(0.1$ V + 3% of the setting)	Same as the 701981
Minimum input voltage ²	500 mVp-p	Same as the 701981
Input impedance	Approx. 10 k Ω and 9 pF	Approx. 1 M Ω and 10 pF
Preset threshold levels	CMOS (5 V) = 2.5 V, CMOS (3.3 V) = 1.6 V, ECL = -1.3 V	Same as the 701981

¹ The 701980 can be used only when the firmware version of the DL7400 is 1.30 or later.

² Under standard operating conditions (see section 17.12) after the warm-up

³ At 1 kHz or less

3.6 Connecting Logic Probes (Optional)

Connection Procedure

1. Turn OFF the DL7400.
2. Connect the B9852VN cable to the logic probe.
3. Connect the B9852VM probe tip (B9852VL if the logic probe is 701980) and the B9852VU earth lead to the logic probe.
To observe high-speed signals, connect the B9852VV earth lead (for terminal) to the GND terminal of the B9852VM probe tip.
4. If the logic probe is 701981, connect the B9852VY pincher tip to the tip of the B9852VM probe tip and the B9852VX pincher tip to the tip of the B9852VU or B9852VV earth lead. If the logic probe is 701980, connect the B9852VY pincher tip to the tip of the B9852VL probe tip and the B9852VZ pincher tip to the tip of the B9852VU earth lead.
5. Connect the other end of the B9852VN cable to the logic probe input connector of the DL7400.
6. Turn ON the power to the DL7400.
7. Connect the other end of the B9852VU or B9852VV (only when the logic probe is 701981) earth lead to the ground potential of the circuit being measured. To observe high-speed signals, connect the B9852VV earth lead (for terminal) to the ground potential of the circuit being measured.
8. Connect the B9852VY pincher tip that was connected to the probe tip to the item being measured.

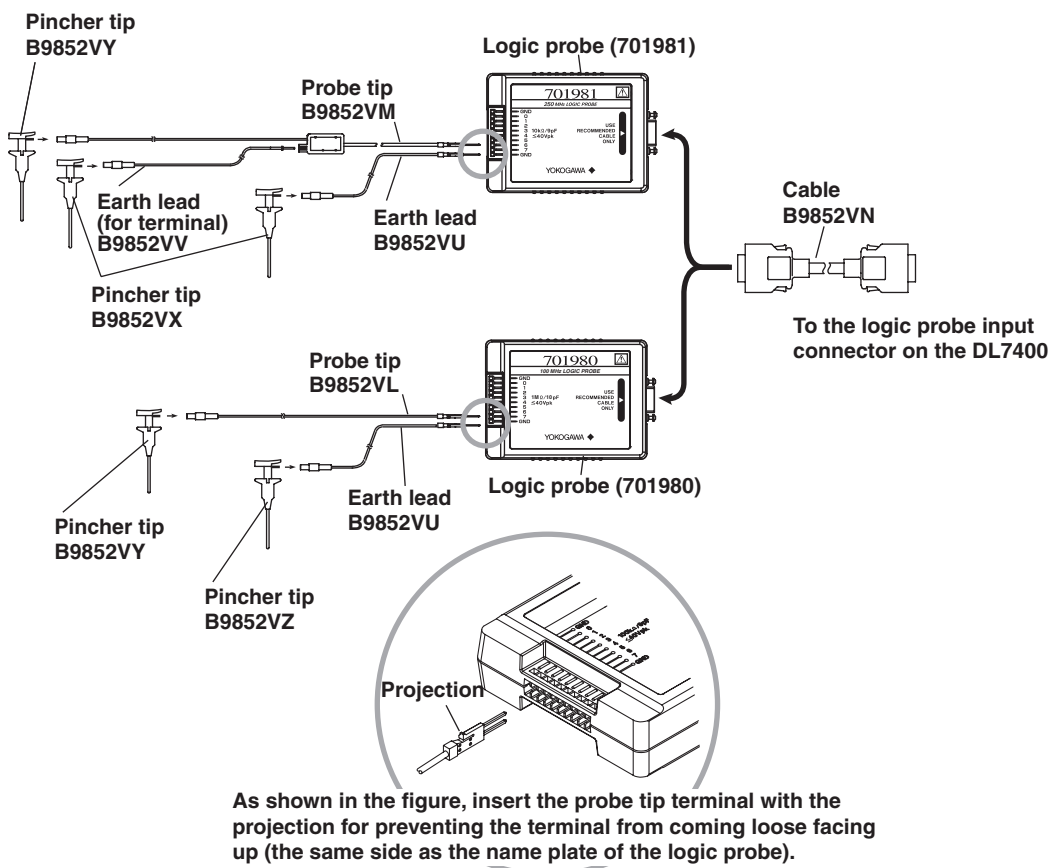

Note

If the logic probe is not connected to the DL7400, the logic probe input is at low level.

3.7 Setting the Date and Time

Procedure

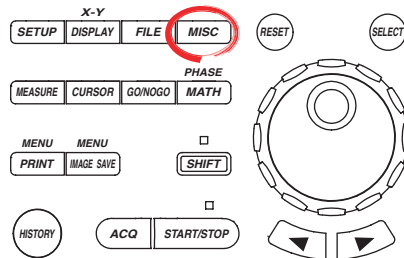

- To exit the menu during operation, press **ESC** located above the soft keys.
- In the procedural explanation below, the term *jog shuttle* & **SELECT** refers to the operation of selecting/setting items and entering values using the **jog shuttle**, **SELECT** and **RESET** keys. For details on this operation, see sections 4.1 or 4.2.
- For a description of the operation using a USB keyboard or a USB mouse, see section 4.3.

There are two ways of setting the date and time. One is to enter the date/time manually. The other is to automatically set the time using the Internet Time Server (NTP Server or SNTP Server). To use the NTP server or SNTP server, the DL7400 must be connected to the network and set up so that a connection can be established with the NTP server or SNTP server. For details, see section 13.2, "Setting Up TCP/IP" and section 13.8, "Setting the Time Difference from GMT (Greenwich Mean Time)/Setting SNTP."

Displaying the Date/Time Setup Dialog Box

1. Press **MISC**.
2. Press the **System Config** soft key. The System Config menu appears.
3. Press the **Date/Time** soft key. The Date/Time setup dialog box appears.

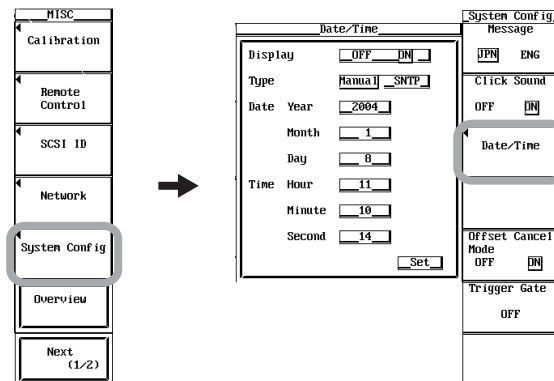

Turning ON/OFF the Date/Time Display

4. Use **jog shuttle** & **SELECT** to set Display to ON or OFF.

Entering the Date/Time

5. Turn the **jog shuttle** to move the cursor to Type, and press **SELECT** to select Manual.
6. Use **jog shuttle** & **SELECT** to set the Year.
7. Likewise, set the Month, Day, Hour, Minute, and Second.
8. Turn the **jog shuttle** to move the cursor to **Set** and press **SELECT** to enter the date/time.

Using the NTP Server or SNTP Server to Set the Date/Time (Firmware Version 1.30 or Later)

5. Turn the **jog shuttle** to move the cursor to Type, and press **SELECT** to select SNTP.
6. Use **jog shuttle & SELECT** to set the Time Hour of Time Difference from GMT in the range of -12 to 13.
7. Likewise, set the Minute of Time Difference from GMT in the range of 0 to 59.
8. Turn the **jog shuttle** to move the cursor to **Set** and press **SELECT**. If the DL7400 is connected to the network and the NTP server or SNTP server is already specified, pressing SELECT will make the DL7400 retrieve the date/time information from the NTP Server or SNTP Server and automatically set the current date/time by calculating the specified time difference from GMT. If the time information cannot be retrieved such as due to an incorrect assignment of the SNTP server, an error message is displayed.

The screenshot shows a menu titled "Date/Time" with the following fields and buttons:

- Display: OFF [DN]
- Type: Manual [SNTP]
- Time Difference From GMT:
 - Time Hour: 9
 - Minute: 0
- [Set]

Explanation

Date (Year/Month/Date)

Set the year, month and day. The selectable range of years is 1999 to 2079.

Time (Hour/Minute/Second)

Set the time using a 24-hour clock.

Automatically Setting the Date/Time Using the NTP Server or SNTP Server (Firmware Version 1.30 or Later)

On models with the Ethernet Interface installed, the DL7400 can behave as an SNTP client to retrieve data/time information from a specified NTP server or SNTP server on the Internet and automatically set the date/time. After retrieving the current date/time information, the date/time information is retrieved every time the power to the DL7400 is turned ON.

For the procedure of specifying the SNTP server, see section 13.8, "Setting the Time Difference from GMT (Greenwich Mean Time)/Setting SNTP."

The time difference from GMT that you specify here is synchronized to the Time difference From GMT setting in section 13.8, "Setting the Time Difference from GMT (Greenwich Mean Time)/Setting SNTP."

Note

- The date/time setting is backed up with the lithium battery when the power is turned OFF.
- Leap years are supported.

4.1 Operations and Functions of Keys and the Jog Shuttle

Basic Key Operations

Displaying the Setup Menu of the Panel Keys

1. Press the desired panel operation key. The setup menu for that key appears.
2. Press the soft key corresponding to the desired setup menu item.

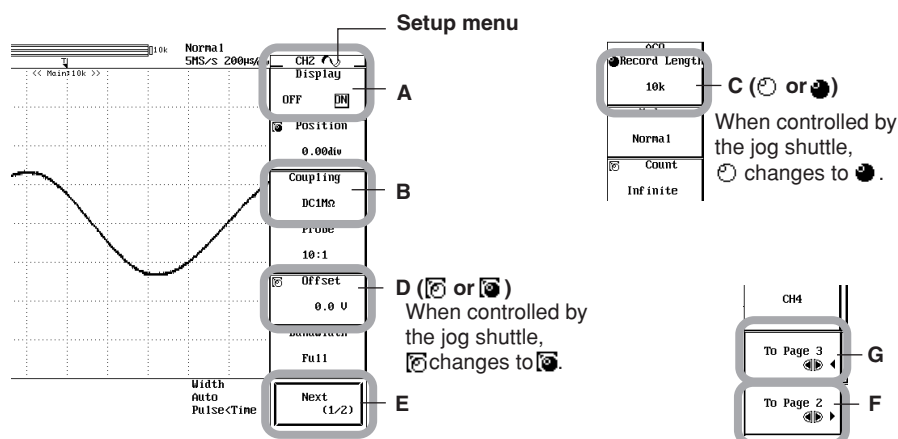

- A: Press the corresponding soft key to switch the selected item.
- B: Press the corresponding soft key to display the selection menu. Press the soft key corresponding to a selection to make the selection.
- C: Press the corresponding soft key to place the item under jog shuttle control. Turn the jog shuttle to change the setting. Press RESET to set the item back to the initial setting.
- D: Press the corresponding soft key to set the item under jog shuttle control. Turn the jog shuttle to set the value. Press the arrow keys to move along the digits. You can directly enter the value using the USB keyboard.
- E: Appears when there are 2 pages of the setup menu. Press the corresponding soft key to display the page 2/2 (2 of 2) of the setup menu. The name changes to "Back (2/2)." To return to page 1/2 (1 of 2), press the corresponding soft key again.
- F: Appears when the soft key selections span over multiple pages. Press the corresponding soft key or the right arrow key to display the next page of the menu. If there are 3 pages, the pages advance in the following order: page 1 → page 2 → page 3 → page 1 → page 2, and so on. Press the left arrow key to move through the pages in the reverse direction.
- G: Appears when the soft key selections span over 3 or more pages. Press the corresponding soft key to move through the pages of the menu in the direction opposite to that described in F.

Displaying the Setup Menu Marked in Purple above the Panel Keys

In the explanations in this manual, "SHIFT + panel key name (purple text)" refers to the following operation.

1. Press the **SHIFT** key. The green indicator above SHIFT illuminates to indicate the shifted state. The setup menu marked in purple above the panel keys can be selected.
2. Press the panel key corresponding to the setup menu you wish to display.

4.1 Operations and Functions of Keys and the Jog Shuttle

Operations on the Setup Dialog Box

In the explanations in this manual, “**jog shuttle & SELECT**” refers to the following operation.

1. Open the setup dialog box using basic key operations or other means.
2. Turn the **jog shuttle** to move the cursor to the desired item.
3. Press **SELECT**. The behavior that results when you press SELECT varies depending on the item as described below.
 - * When selecting a medium, directory, or file name on the File List window, you operate the jog shuttle to move the cursor and select using the SELECT key. This operation is also referred to as “jog shuttle & SELECT.”

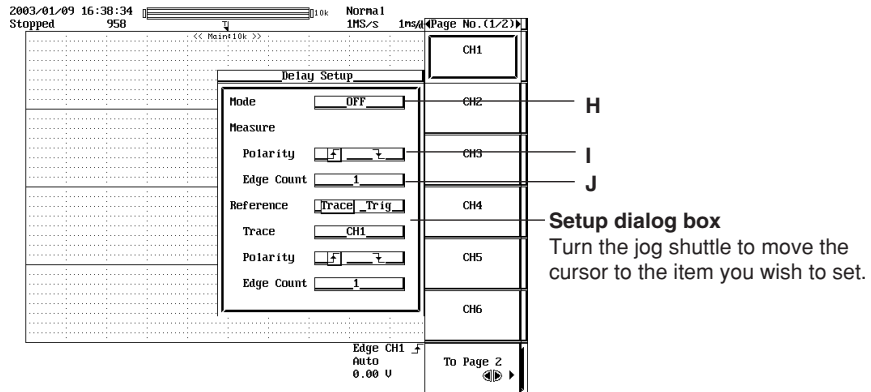

When Mode is selected (H)

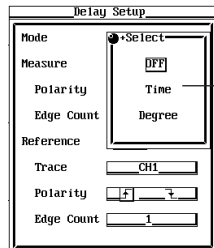

When Edge Count is selected (J)

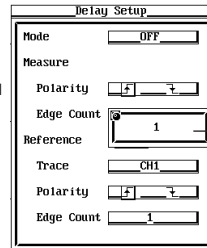

H: Press **SELECT** to display the selection menu.
Turn the jog shuttle to move the cursor to the item you wish to set.
Press **SELECT** to confirm the selection.

I: Press **SELECT** to switch the selected item.

J: Press **SELECT** to display the value entry box.
Turn the jog shuttle to set the value.
Press the arrow keys to change the selected digit.
You can directly enter the value from a USB keyboard.
Press **RESET** to set the item back to the initial setting.

Clearing the Setup Menu and Setup Dialog Box Displays

Press **ESC**. The setup menu or the dialog box shown on top is cleared from the screen.

Note

- In the procedural explanations in this manual, the operation of clearing the setup menu or setup dialog box may not be given.
- If the setup menu is cleared when the automated measurement values of waveform parameters or cursor measurement values are displayed in the waveform display area, these measured values are displayed at the display position of the setup menu.

4.2 Entering Values and Strings

Entering Values

Entering Values Directly Using the Dedicated Knobs

The dedicated knobs indicated below can be turned to directly enter values.

- V/DIV knob
- TIME/DIV knob

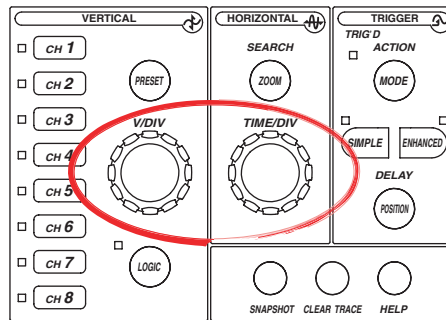

Entering Values Using the Jog Shuttle

After selecting the setup item using the soft key, use the jog shuttle to change the value (in the explanations in this manual, this operation may be indicated as “**jog shuttle & SELECT**”). The outer shuttle ring can be used step through the values in large increments. On some items, the arrow keys below the jog shuttle can be used to change the selected digit.

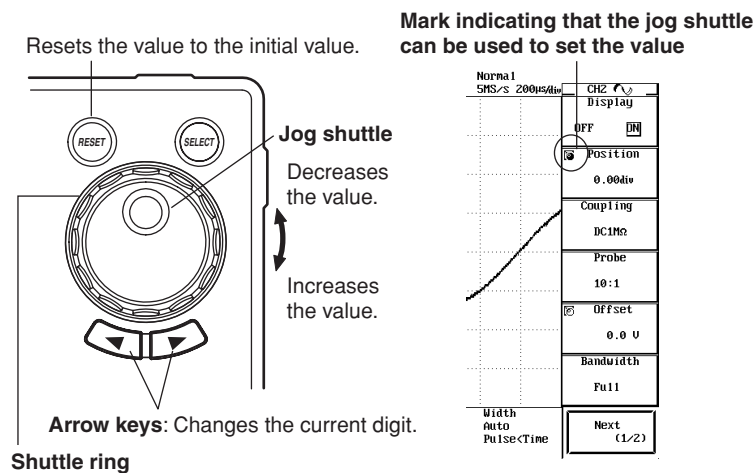

Note

The items that can be changed using the jog shuttle are reset to their default values when the RESET key is pressed.

Entering Strings

The keyboard displayed on the screen is used to enter character strings such as file names and comments. The jog shuttle, SELECT, and arrow keys are used to operate the keyboard to enter the character strings.

Operating the Keyboard

1. Turn the **jog shuttle** to move the cursor to the character to be entered. You can also press the soft keys corresponding to ▲ and ▼ to move the cursor vertically.
2. Press **SELECT** key to enter the character. If a character string has already been entered, move the cursor to the position in the string at which you want to enter a character.
3. Repeat steps 1 and 2 to enter all the characters in the string.
4. Selecting ENT on the keyboard and pressing **SELECT** confirms the string and the keyboard disappears. You can also press the ENT soft key to confirm the string and clear the keyboard. At the same time, the confirmed string is temporarily stored. If you wish to clear the entire string that you have entered, press **RESET** before confirming the string.

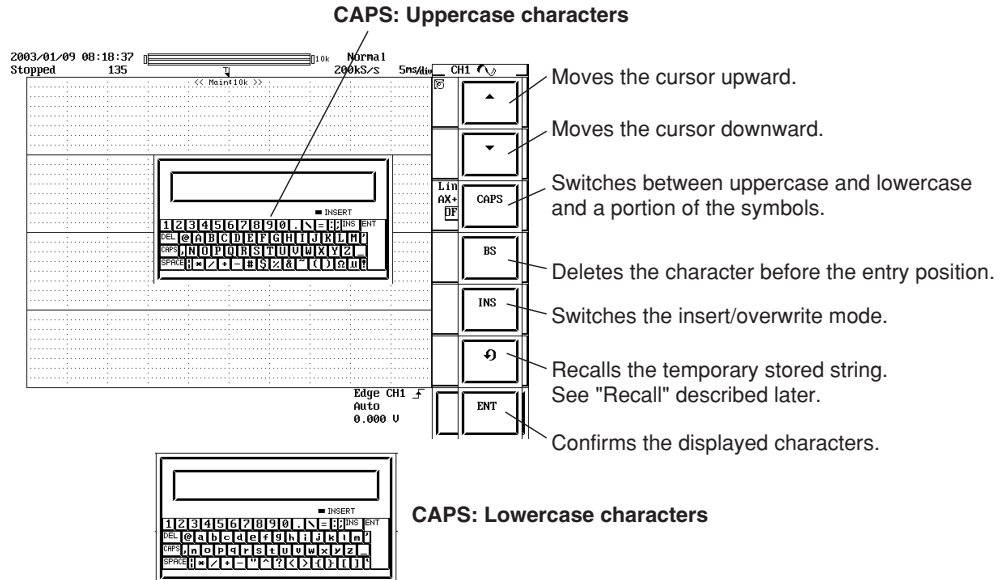

Note

When using the user-defined computation (option, see section 9.9), a keyboard for setting the computation appears. The basic setup procedure is the same as the procedure explained here.

Temporary Storage of Character Strings

Up to 8 confirmed strings are automatically stored. When the number of confirmed strings exceeds 8, the strings are deleted in order starting from the oldest string. For items with a string set as a default value such as channel labels, up to 8 strings including the initial string can be temporarily stored. Even when the number of confirmed string exceeds 8, the default string is not cleared. The oldest of the 7 confirmed strings excluding the default string is deleted.

Recalling

(Note that the unconfirmed string that is displayed in the entry box of the keyboard is overwritten when a string is recalled using the procedure in step 1 below.)

1. Every time the  soft key is pressed, strings that are temporarily stored appear in order from the newest string in the input box of the keyboard. When the 8 strings that are temporarily stored are displayed, the newest string is displayed again.
2. You can also edit the recalled string by performing steps 1 to 4 of "Entering Strings" described above. When the string is confirmed, it is temporarily stored as a new string.

Keys Other Than the Character Keys

DEL

Deletes the character at the cursor.

INS

Switches the insert/overwrite mode. When in insert mode, the INSERT indicator on the keyboard illuminates.

SPACE

Enters a space.

ENT

Confirms the displayed characters.

CAPS

Switches between uppercase and lowercase. Also switches a portion of the characters assigned to the keyboard.

Number of Characters and Types That Can Be Used in the Settings

Number of Characters	Characters That Can Be Used	
Date/Time	Specified number	0 to 9(/ :)
File name	1 to 14 characters	0 to 9, A to Z, %, _, (,), and -
Comments for screen images	0 to 20 characters	All characters (including spaces)
Comments for files	0 to 25 characters	All characters (including spaces)
Comments for e-mails	0 to 30 characters	All ASCII characters on the keyboard (including spaces)
E-mail address	0 to 40 characters	All ASCII characters on the keyboard (including spaces)
User name and login name	0 to 15 characters	All ASCII characters on the keyboard (including spaces)
Password	0 to 15 characters	All ASCII characters on the keyboard (including spaces)

Note

- Multiple @ characters cannot be entered consecutively.
- File names are not case-sensitive. Comments are case-sensitive. In addition, the following file names cannot be used due to limitations of MS-DOS.
AUX, CON, PRN, NUL, CLOCK, COM1 to COM9, and LPT1 to LPT9

4.3 Operating the DL7400 Using a USB Keyboard or a USB Mouse

Connecting a USB Keyboard

You can connect a USB keyboard for entering file names, comments, and other information. In addition, the functions of each key on the front panel of the DL7400 are assigned to the keys on the keyboard (see appendix 6). Thus, the keyboard can be used to carry out operations that are the same as the key operations on the DL7400.

Keyboards That Can Be Used

Keyboards that can be used depend on the USB keyboard language that you selected in section 15.2 (English or Japanese). The following keyboards that conform to USB Human Interface Devices (HID) Class Version 1.1 can be used.

- When the USB keyboard language is English: 104 keyboard and 89 keyboard
- When the USB keyboard language is Japanese: 109 keyboard and 89 keyboard

The default setting is the language specified by the message language selection (see section 15.1). To use a Japanese keyboard, change the USB keyboard language according to the procedures given in section 15.2.

Note

- Connect only the keyboards that are allowed.
- The operation of USB keyboards connected to a USB hub or those that have mouse connectors is not guaranteed.
- For USB keyboards that have been tested for compatibility, contact your nearest YOKOGAWA dealer.

USB PERIPHERAL Connector

Connect the USB keyboard to the USB PERIPHERAL connector on the rear panel. There are two USB PERIPHERAL connectors (ports).

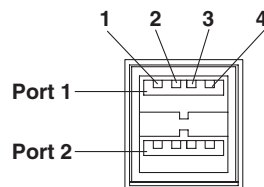

Pin No.	Signal Name
1	VBUS: +5V
2	D-: -Data
3	D+: +Data
4	GND: Ground

Connection Procedure

When connecting a USB keyboard, directly connect the keyboard to the DL7400 using a USB cable as shown below. You can connect the USB cable regardless of whether the power to the DL7400 is ON or OFF (supports hot-plugging). Connect the type A connector of the USB cable to the DL7400; connect the type B connector to the keyboard. When the power switch is ON, the keyboard is detected and enabled approximately six seconds after it is connected.

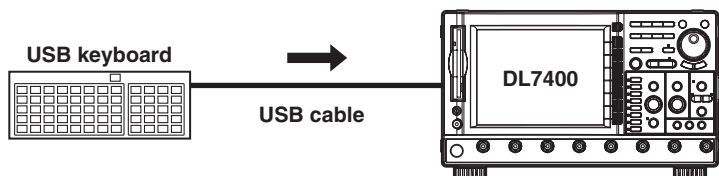

Note

- Connect the keyboard directly without going through a USB hub.
- Do not connect USB devices other than a USB keyboard, USB mouse, or printer to the USB PERIPHERAL connector.
- Do not connect multiple keyboards. Only 1 keyboard, 1 mouse, and 1 printer can be connected.
- Holding down a key on the keyboard does not enter the character or value repeatedly.
- Do not connect and disconnect multiple USB devices successively. Allow at least ten seconds between the connection and disconnection of a USB device and the connection and disconnection of the next USB device.
- Do not disconnect the USB cable after the power is turned ON until key operation becomes possible (approximately 20 to 30 s).

Confirming the Type of Keyboard That Is Connected

To determine the type of keyboard that is connected to the DL7400, follow the procedure given in section 15.2.

Entering File Names, Comments, and Other Items

When a keyboard is displayed on the screen, you can enter the file name, comment, and other items using a USB keyboard. The character that is entered through each key of the USB keyboard varies depending on the keyboard type. For details, see appendix 6.

Executing Functions Corresponding to the Front Panel Keys of the DL7400

The functions corresponding to the front panel keys of the DL7400 are assigned to the keys on the USB keyboard. By pressing the keys on the keyboard, you can operate the DL7400 in a similar fashion. The assignment of functions varies depending on the keyboard type. For details, see appendix 6.

4.3 Operating the DL7400 Using a USB Keyboard or a USB Mouse

Entering Values from a USB Keyboard

You can enter values from a USB keyboard for items with the  or  icon.

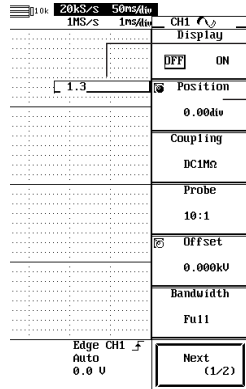

Value entered using the keyboard

Press the corresponding key and then enter the value using the USB keyboard. Press the Enter key to enter the value.

Entering Values with Prefix Units

If a prefix unit is shown as in “Offset” in the above example, you can enter not only the value but also the prefix unit from the USB keyboard. The items for which you can enter prefix units are voltage (V), time (seconds: s), and current (A).

Entry Example

- Entering **1**, then **Enter** under Offset is equivalent to entering 1 V, and the screen displays 1000 mV or 1.0 V.
- Entering **1, 0**, then **m** under Offset is equivalent to entering 10 mV, and the screen displays 10 mV or 0.01 V. If you enter the prefix unit from a USB keyboard, you do not have to press the Enter key.

Input Key	Prefix Unit
K or k	10 ³ (kilo)
m	10 ⁻³ (milli)
U or u	10 ⁻⁶ (micro)
N or n	10 ⁻⁹ (nano)
P or p	10 ⁻¹² (pico)

Operations Using a USB Mouse

You can use a USB mouse to operate the DL7400 as you would using the front panel keys. In addition, you can point to a desired item on a menu and click the item. This is analogous to pressing a soft key corresponding to a menu and pressing the SELECT key.

USB PERIPHERAL Connector

The USB mouse is connected to the USB PERIPHERAL connector on the rear panel of the DL7400. For details on the USB PERIPHERAL connector, see page 4-6.

Compatible USB Mouse

A USB wheel mouse conforming to USB HID Class Version 1.1 can be used.

Note

- For USB mouse devices that have been tested for compatibility, contact your nearest YOKOGAWA dealer.
- Some items cannot be specified when using a mouse without a wheel.

Connection Procedure

When connecting a USB mouse, directly connect the mouse to the USB PERIPHERAL connector using a USB cable. You can connect/disconnect the USB mouse connector regardless of the power ON/OFF state of the DL7400 (supports hot-plugging). When the power switch is turned ON, the mouse is detected approximately six seconds after it is connected, and a pointer () is displayed.

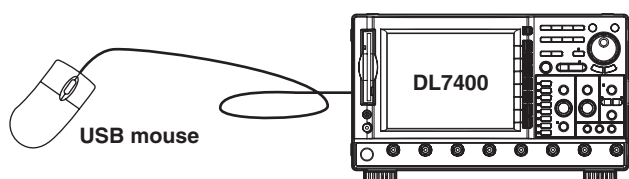

Note

- Do not connect USB devices other than a USB keyboard, USB mouse, or USB printer to the USB PERIPHERAL connector.
- There are two USB PERIPHERAL connectors on the DL7400. However, do not connect mouse devices to both connectors at the same time.

Confirming the Type of USB Mouse That Is Connected

The procedure for confirming the type of USB mouse that is connected to the DL7400 is the same as the procedure for confirming the type of USB keyboard. See section 15.2.

USB Mouse Operation

Operations Similar to the Front Panel Keys (Top Menu)

• **Displaying the Top Menu**

Right-click on the screen. The front panel key names on the DL7400 are displayed as the top menu.

• **Selecting Items on the Top Menu**

Point to the item you wish to select and left-click the item. The setup menu corresponding to the selected item is displayed on the right side of the screen. The top menu is cleared from the screen. Pointing to items with a sub menu (items with a > mark displayed to their right) displays the sub menu. As with the top menu, point to the item you wish to select and left-click the item.

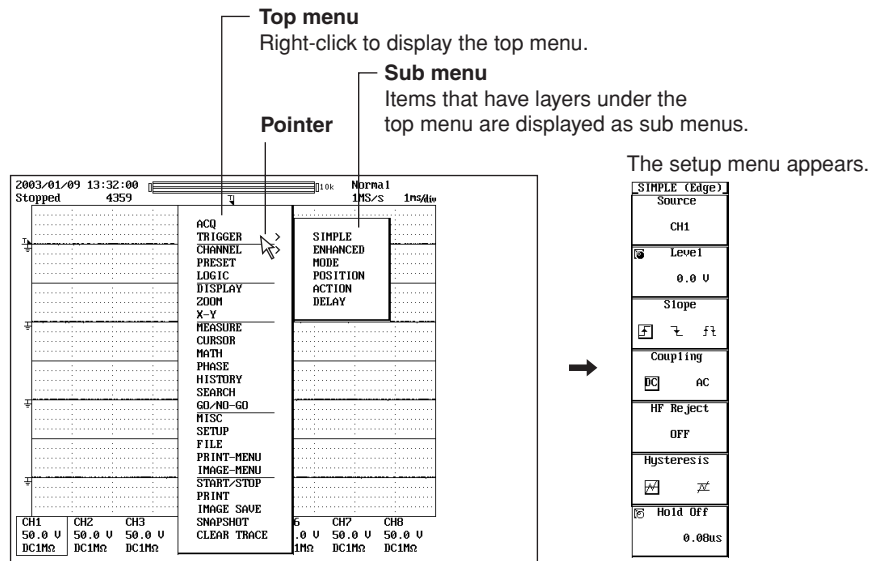

Note

- The following key names do not appear on the top menu.
ESC, RESET, SELECT, HELP, and arrow keys
- The top menu also displays characters that are marked in purple above the panel keys.
- The TRIGGER sub menu contains the following TRIGGER group panel key names.
MODE, SIMPLE/ENHANCED, POSITION, ACTION, and DELAY
- To display the PRINT menu or the IMAGE SAVE menu, select PRINT-MENU or IMAGE-MENU, respectively. To execute the PRINT or IMAGE SAVE operation, select PRINT or IMAGE SAVE, respectively.

Setup Menu Operation (Similar to the Soft Key Operation)

- **Selecting an Item on the Setup Menu**

Left-click the item you wish to select on the setup menu. If another menu appears when you select an item, move the pointer to the new menu displaying the item you wish to select and left-click the item. If an item such as ON or OFF appears when you select an item, move the pointer to the new frame and left-click within the frame to switch the selected item.

For menus in which items are selected using jog shuttle & SELECT (see page 4-3), left-click the desired item. Left-click again to confirm the new setting and close the selection dialog box. You can turn the mouse wheel to select scrollable items.

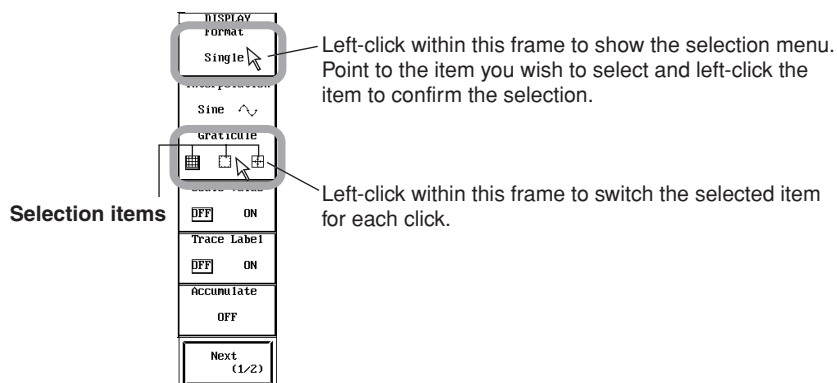

- **Clearing the Menu**

Left-click an area outside the menu.

Setting Values

For menu items with a or icon, the numeric value can be entered as follows:

- To select a menu item with a or icon, left-click the center of the menu item. If there are two setup items in a single menu item, you can repetitively left-click to select either item.
- Turn the mouse wheel downward to increase the value.
- Turn the mouse wheel upward to decrease the value.
- To change the selected digit, move the pointer to the left or right of the value. The pointer changes to or . Left-click to the left or right of the value. If you point to the left of the value and left-click, the current digit moves to the left; if you point to the right of the value and left-click, the current digit moves to the right. The current digit moves one digit at a time for each left-click.
- To restore a value's default setting, right-click on the value's menu item.

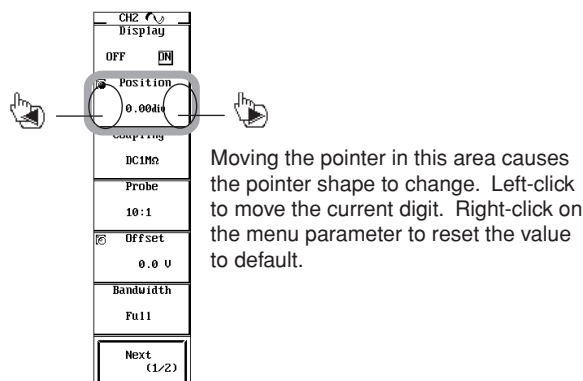

4.3 Operating the DL7400 Using a USB Keyboard or a USB Mouse

Selecting Toggle Box Items on the Dialog Box

Left-click the item you wish to select. The item is selected. Click the selected item again to deselect it. To close the dialog box, point to an area outside the dialog box and left-click.

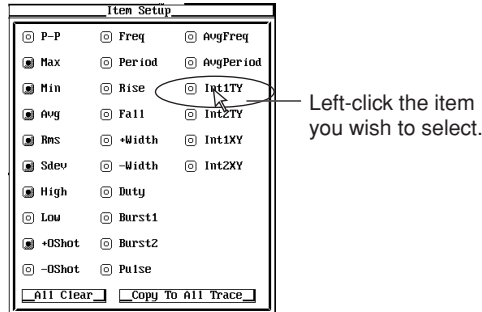

Note

To close an error dialog box, left- or right-click or turn the mouse wheel without moving the mouse.

Selecting a File, Directory, or Disk Drive on the File List Window

Left-click a file, directory, or disk drive name to select it. Turn the mouse wheel to scroll through the file list. To cancel the selection, point to an area outside the file list window and left-click. The selection is cancelled, and the file list window closes.

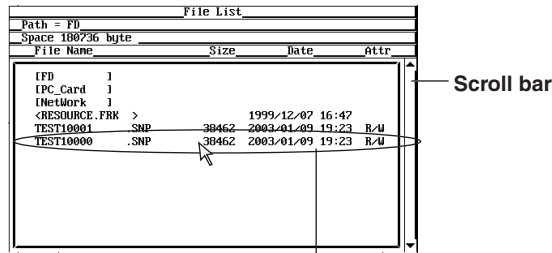

Move the pointer to the file, directory, or storage medium you wish to select and left-click.

Setting V/div and T/div

- **Setting V/div**

When the waveform of a channel measuring a voltage is displayed, point near the V/div value displayed at the bottom of the screen. The pointer changes to . Left-click on the V/div value of the channel you wish to set. The target V/div value is enclosed in a box and selected. Turning the mouse wheel upward increases the V/div value; turning it downward decreases the V/div value.

- **Setting T/div**

Point near the T/div value displayed at the upper right corner of the screen. The pointer changes to . Turning the mouse wheel upward increases the T/div value; turning it downward decreases the T/div value.

Moving the pointer to the position indicated below changes the pointer display. You can change the V/div or T/div setting by turning the wheel in this condition.

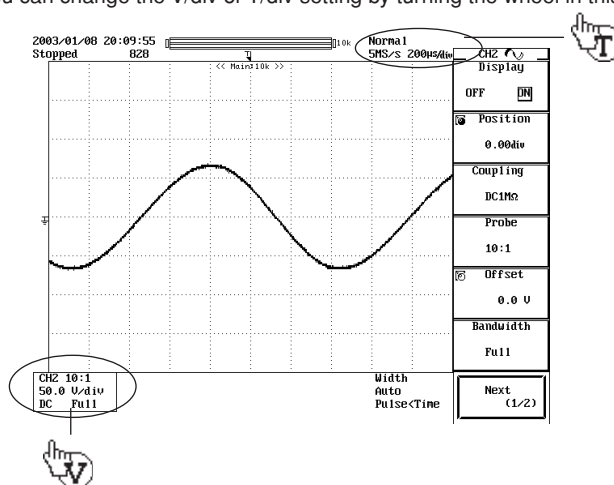

4.4 Initializing Settings

Procedure

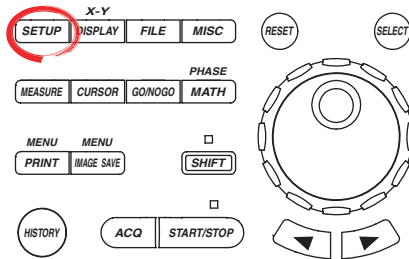

- To exit the menu during operation, press **ESC** located above the soft keys.
- For a description of the operation using a USB keyboard or a USB mouse, see section 4.3.

Executing Initialization

1. Press **SETUP**. The SETUP menu appears.
2. Press the **Initialize** soft key. Initialization is executed.

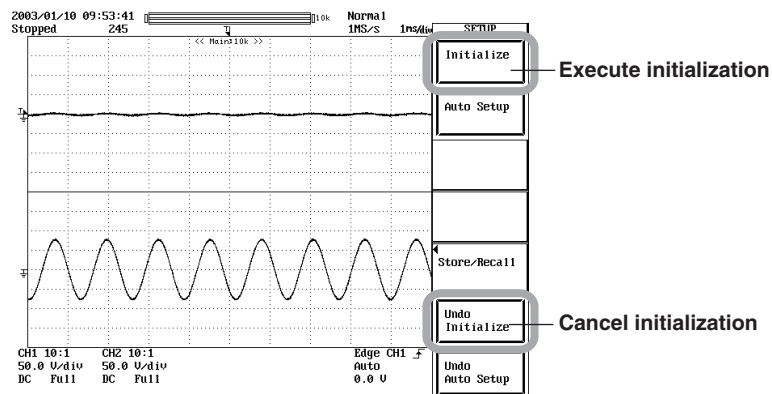

Canceling Initialization

3. Press the **Undo Initialize** soft key. The settings return to the conditions that existed immediately before initialization.

Note

When you turn OFF the power switch, the settings that existed immediately before initialization are cleared. Therefore, the "Undo" operation is not possible in this case.

Explanation

You can restore the factory default settings. This is useful when you wish to clear previous settings or start measurement from scratch.

Initialization

Initialization refers to the act of restoring the factory default settings. For a description of the factory default settings, see appendix 5.

Items That Cannot Be Initialized

- Date/Time setting
- Settings related to communications
- Setup data that has been stored using the store/recall function
- English/Japanese language setting
- USB keyboard language
- SCSI ID setting (when the SCSI interface option is installed)

Canceling Initialization

If you initialize the settings by mistake, you can press the Undo Initialize soft key to return to the settings that existed before the initialization.

Initializing All the Settings

When the power is turned ON while holding down the RESET key, all settings excluding the date/time setting (display ON/OFF is initialized) are initialized to factory default settings. Setup data that has been stored using the store/recall function is also initialized. If you initialize the DL7400 in this fashion, the settings cannot be set back to their original condition.

4.5 Performing Auto Setup

Procedure

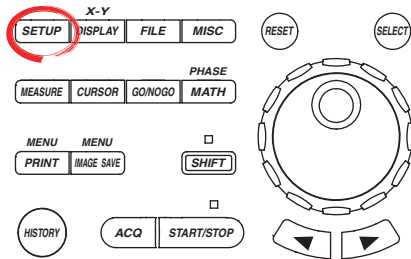

- To exit the menu during operation, press **ESC** located above the soft keys.
- For a description of the operation using a USB keyboard or a USB mouse, see section 4.3.

Executing Auto Setup

1. Press **SETUP**. The SETUP menu appears.
2. Press the **Auto Setup** soft key. Auto setup is executed. When auto setup is executed, waveform acquisition starts automatically.

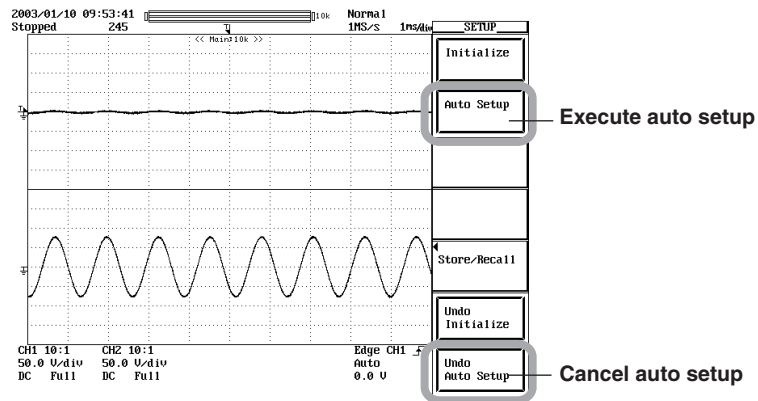

Canceling Auto Setup

3. Press the **Undo Auto Setup** soft key. The settings are set back to their original condition.

Explanation

The auto setup function automatically sets the key settings such as V/div, T/div, and trigger level that are appropriate for the input signal.

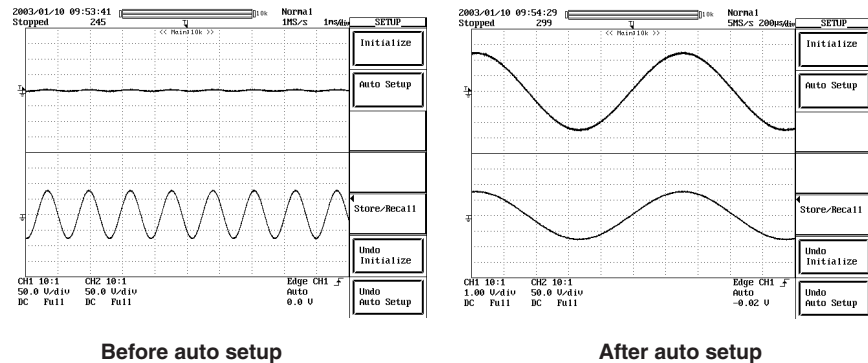

Before auto setup

After auto setup

Center Position after Auto Setup

The center position after auto setup is 0 V.

Applicable Channels

Auto setup is performed on all channels.

Loaded Waveforms

When auto setup is executed, loaded waveforms are unloaded (cannot be recovered using the Undo Auto Setup soft key).

Canceling Auto Setup

Pressing the Undo Auto Setup soft key sets the DL7400 back to the settings that existed immediately before auto setup. However, when you turn OFF the power switch, the settings that existed immediately before auto setup are cleared. Therefore, the “Undo” operation is not possible in this case.

Applicable Waveforms for Auto Setup

Frequency	Approx. 50 Hz or higher
Absolute value of the input voltage	Maximum value is greater than or equal to approximately 20 mV (1:1)
Type	Repetitive waveform (that is not complex)

Note

The auto setup function may not work properly if the waveform includes DC components or high-frequency components.

4.5 Performing Auto Setup

Setup Data after Executing Auto Setup

Waveform acquisition/display conditions

Acquisition mode	Normal
Acquisition Count	Infinite
Record length	10 k
Interleave mode	OFF
Time base	Int
Accumulate mode	OFF
Zoom target	Channels that are turned ON Waveforms whose Allocation on the ZOOM menu is OFF are not displayed.

Vertical-axis settings

V/div	Value that causes the absolute value of the input waveform to be 1.6 to 4 divisions
Offset voltage	0 V
Coupling	DC1M Ω for inputs other than DC50 Ω and DC50 Ω for DC50 Ω
Bandwidth limit	FULL
Display ON/OFF	Turns ON channels whose absolute value of the input voltage is greater than or equal to 20 mV (1:1)
Position	0 divisions

Horizontal-axis settings

T/div	Value that displays 1.6 to 4 periods of the waveform with the shortest period of the auto setup target waveforms
-------	--

Trigger settings

Trigger mode	Auto
Trigger type	Simple
Trigger source	Channel whose waveform amplitude is greater than or equal to 1 division with the longest period
Trigger level/slope	Center level between the maximum and minimum values/rising
Trigger coupling	DC
HF rejection	OFF
Hysteresis	A
Hold off time	80 ns
Trigger position	50%
Trigger delay	0 s
Trigger gate	OFF

Computation settings

Scaling	Auto
---------	------

Items other than those listed above are not applicable for auto setup.

4.6 Performing Calibration

Procedure

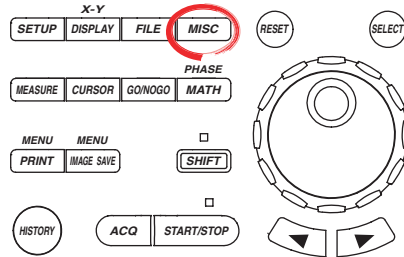

- To exit the menu during operation, press **ESC** located above the soft keys.
- For a description of the operation using a USB keyboard or a USB mouse, see section 4.3.

1. Press **MISC**. The MISC menu appears.
2. Press the **Calibration** soft key. The Calibration menu appears.
3. Press the **Auto Cal** soft key to select ON or OFF.

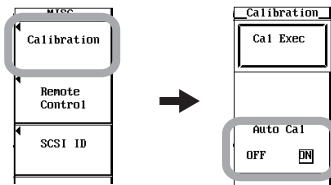

4. Press the **Cal Exec** soft key. Calibration is executed.

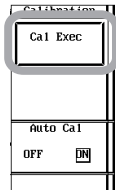

Explanation

Calibration

The following items are calibrated. Perform calibration when you wish to measure waveforms with high accuracy.

- Ground level and gain of the vertical axis
- Trigger threshold level
- Time measurement value during repetitive sampling

Note

The calibration described above is performed automatically when the power switch is turned ON.

Precautions to Be Taken When Performing Calibration

- Always allow the instrument to warm up for at least 30 minutes after the power is turned ON before starting calibration. If calibration is performed immediately after the power is turned ON, the calibration may be inaccurate due to drift caused by fluctuation in the temperature of the instrument.
- Calibration must be performed when the temperature of the instrument is stable and is between 5°C and 40°C (preferably at 23°C±5°C).
- Do not apply a signal when performing calibration. Calibration may be executed incorrectly when an input signal is being applied.

Auto Calibration

Calibration is automatically performed when T/div is changed and waveform acquisition is started for the first time after the following time elapses after turning ON the power.

- 3 minutes
- 10 minutes
- 30 minutes
- 1 hour and every hour thereafter

If calibration is executed while a signal is applied to the DL7400, it is recommended that the DL7400 be recalibrated without applying a signal.

4.7 Correcting the Delay Time of the Input Signals

Procedure

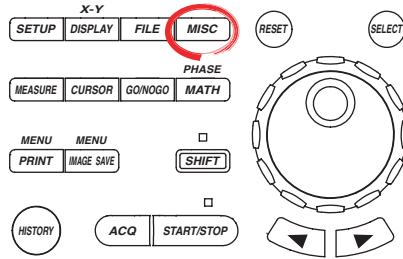

- To exit the menu during operation, press **ESC** located above the soft keys.
- For a description of the operation using a USB keyboard or a USB mouse, see section 4.3.

1. Press **MISC**. The MISC menu appears.
2. Press the **Calibration** soft key. The Calibration menu appears.

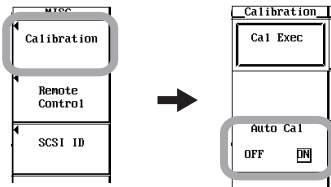

3. Press the **Deskeu** soft key to select ON or OFF.
 - If you select ON, proceed to step 4.
 - If you select OFF, the procedure is complete.

This mark appears when the Deskeu setting is ON and the deskeu time of the selected target CH is set to a value other than 0.00 ns

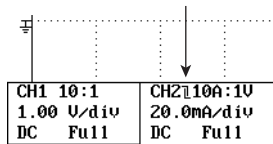

4. Press the **Target CH** soft key. The Target CH menu appears.
5. Press the **CH1 to CH8/4, Pod A, or Pod B** to select the target channel. You can select up to channel CH4 and CH8 on the DL7440 and DL7480, respectively.
6. Turn the **jog shuttle** to set the Deskeu Time.

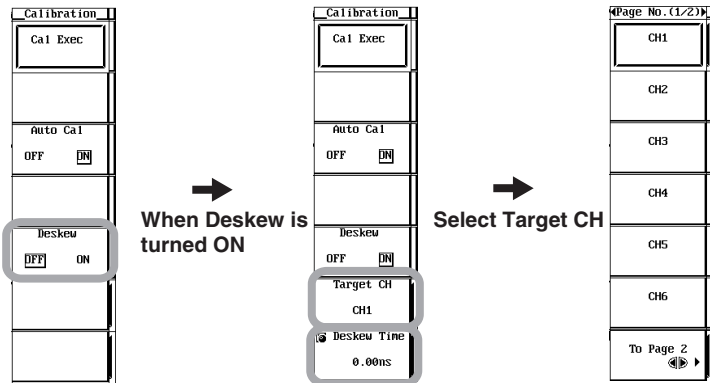

4.7 Correcting the Delay Time of the Input Signals

Explanation

You can use the deskew function to minimize the effects (skew) of the delay time of the input signals due to the probe or other factors, and observe the input signal.

You can correct the delay time of CH1 to CH8/4, Pod A, or Pod B.

You can select up to CH4 and CH8 on the DL7440 and DL7480, respectively.

Selectable Range of Skew Correction

The correction time can be set in the following range.

–100 ns to 100 ns (resolution is 0.01 ns)

4.8 Using the Help Function

Procedure

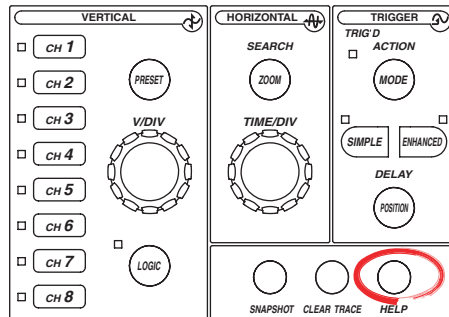

- To exit the menu during operation, press **ESC** located above the soft keys.
- For a description of the operation using a USB keyboard or a USB mouse, see section 4.3.

Displaying the Help Window

1. Press **HELP**. The help window appears.
2. Press the panel key or soft key that you wish to review.

Clearing the Help Window

3. Press **HELP** again. The help window disappears.

Explanation

Displaying the Help Window

When you press **HELP**, a help window containing information about the soft key menu or jog shuttle menu that was displayed immediately before **HELP** was pressed appears. If you press a key while the help window is displayed, a help window containing information about the key appears.

Clearing the Help Window

If you press **HELP** again while a help window is displayed, the help window closes.

5.1 Turning Channels ON/OFF

Procedure

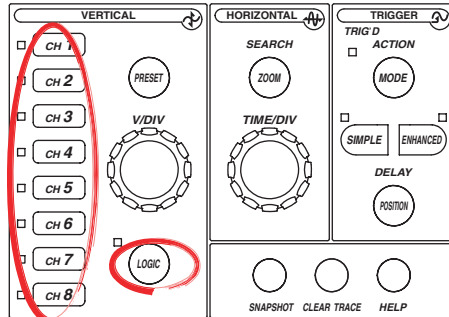

- To exit the menu during operation, press **ESC** located above the soft keys.
- For a description of the operation using a USB keyboard or a USB mouse, see section 4.3.

1. Press one of the **CH1** to **CH8/4** and **LOGIC** keys to select the channel. The CH menu or LOGIC menu appears.
You can select up to channel CH4 and CH8 on the DL7440 and DL7480, respectively.
2. Press the **Display** (when CH1 to CH8/4 is selected) or **Mode** (when Logic is selected) soft key to select ON or OFF. You can also turn ON/OFF the channel by pressing **CH1** to **CH8/4** or **Logic** twice.

Logic input

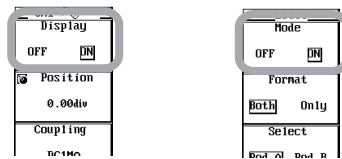

Explanation

For channels that are turned ON, the LED to the left of the channel key illuminates. The input waveform of 8 or 4 channels (CH1 to CH8/4) and the optional logic input waveform can be displayed simultaneously. If the logic input is turned ON, a logic waveform window opens as shown below. You can also display on the logic waveform (see section 8.1).

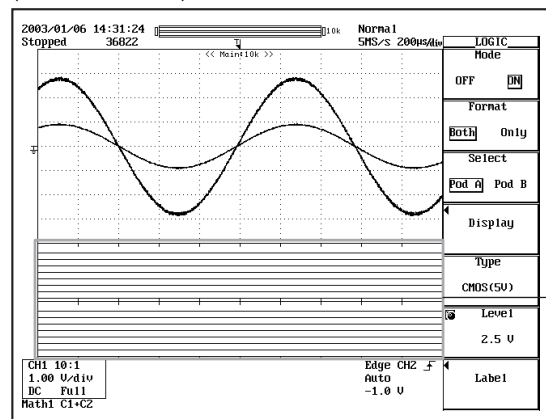

Logic waveform display frame

Note

- The screen can be split into up to eight display areas using the DISPLAY menu (see section 8.1). Scale values (see section 8.8) and waveform labels (see section 8.9) can also be displayed.
- If waveforms are recalled from the history waveforms or loaded from a storage medium such as a floppy disk or Zip disk, the input waveform cannot be displayed. To compare input waveforms and loaded waveforms, use the snapshot function (see section 8.6).

5.2 Setting V/div

<For a description of this function, refer to page 2-2.>

Procedure

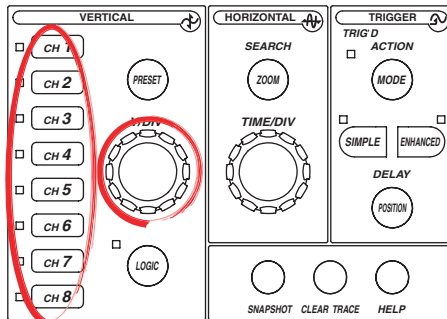

- To exit the menu during operation, press **ESC** located above the soft keys.
- For a description of the operation using a USB keyboard or a USB mouse, see section 4.3.

Using the V/DIV Knob

1. Press one of the **CH1** to **CH8/4** keys to select the channel. The CH menu appears.
You can select up to channel CH4 and CH8 on the DL7440 and DL7480, respectively.
2. Turn the **V/DIV** knob to set the V/div value.

Note

- The displayed waveforms do not change if you change the V/div value while the waveform acquisition is stopped. The new V/div value takes effect the next time the waveform acquisition is started.
- Turning the V/DIV knob while acquisition is stopped has no effect on cursor measurement values and automated measurement values of waveform parameters. The displayed values are for the original V/div setting.

Using the Variable Soft Key

1. Press one of the **CH1** to **CH8/4** keys to select the channel. The CH menu appears.
You can select up to channel CH4 and CH8 on the DL7440 and DL7480, respectively.
2. Press the **Next (1/2)** soft key
3. Press the **Variable** soft key.
4. Turn the **jog shuttle** to set the V/div value.

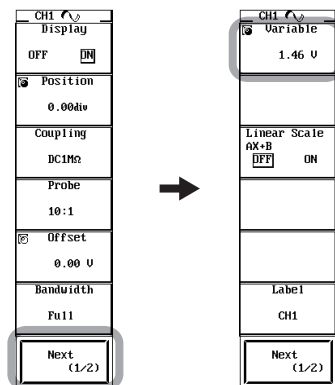

Note

- If you change the V/div value by turning the V/DIV knob, the Variable setting is cancelled.
- If you press the RESET key, the V/div value set using the Variable soft key is reset, and the value returns to the initial V/div value set using the V/DIV knob.

Explanation

The V/div (A/div when current probes are used) setting is used to adjust the displayed amplitude of the waveform for easy viewing. You can set the value in terms of the voltage (current) per division of the screen grid. There are two methods for setting this value.

Using the V/DIV Knob

V/div is set in steps of 1-2-5 (1 V/div → 2 V/div → 5 V/div). This value becomes the reference for the selectable range of settings using Variable (see the next section) and the setup step (resolution).

Selectable Range of V/div

The table below shows the selectable range according to the probe attenuation/current-to-voltage conversion ratio setting (see section 5.5).

Probe Attenuation	Selectable Range (When Input Coupling Is AC1M Ω or DC1M Ω)	Selectable Range (When Input Coupling Is DC50 Ω)
1 : 1	2 mV/div to 10 V/div	2 mV/div to 1 V/div
10 : 1	20 mV/div to 100 V/div	20 mV/div to 10 V/div
100 : 1	0.2 V/div to 1 kV/div	0.2 V/div to 100 V/div
1000 : 1	2 V/div to 10 kV/div	2 V/div to 1 kV/div

Probe Current-to-Voltage Conversion Ratio	Selectable Range (When Input Coupling Is AC1M Ω or DC1M Ω)	Selectable Range (When Input Coupling Is DC50 Ω)
10 A : 1 V	20 mA/div to 100 A/div	20 mA/div to 10 A/div
100 A : 1 V	0.2 A/div to 1 kA/div	0.2 A/div to 100 A/div

Using the Variable Command in the CH Menu

The variable command allows the V/div (A/div) values to be set in smaller steps than the setting entered using the V/DIV knob. It can also be used to expand/reduce the displayed waveform vertically after waveform acquisition. Waveform acquisition can be started using the modified V/div (A/div) setting.

Selectable Range and Resolution

The table below shows the values for the case when the probe attenuation is 10:1.

Setting Using the V/DIV Knob	Selectable Range Using Variable	Resolution
20 mV/div	2.0 mV to 50.0 mV	0.2 mV
50 mV/div	5.0 mV to 100.0 mV	0.5 mV
100 mV/div	10 mV to 200 mV	1 mV
200 mV/div	20 mV to 500 mV	2 mV
500 mV/div	50 mV to 1000 mV	5 mV
1 V/div	0.10 V to 2.00 V	0.01 V
2 V/div	0.20 V to 5.00 V	0.02 V
5 V/div	0.50 V to 10.00 V	0.05 V
10 V/div	1.0 V to 20.0 V	0.1 V
20 V/div	2.0 V to 50.0 V	0.2 V
50 V/div	5.0 V to 100.0 V	0.5 V
100 V/div	10 V to 200 V	1 V

* The values are 1/10th, 10 times, and 100 times the values shown above if the probe attenuation is 1:1, 100:1, and 1000:1, respectively. If the probe current-to-voltage conversion ratio is 10 A: 1 V, the values are the same values shown above with the unit changed to A. If the ratio is 100 A: 1 V, the values are 10 times the values shown above with the unit changed to A.

5.3 Setting the Vertical Position of the Waveform

<For a description of this function, refer to page 2-2.>

Procedure

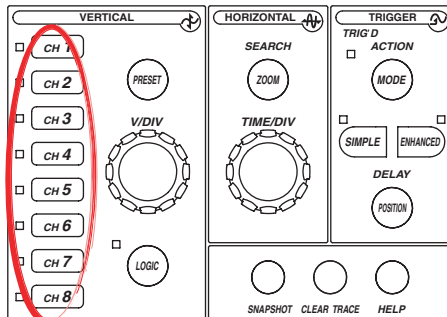

- To exit the menu during operation, press **ESC** located above the soft keys.
- For a description of the operation using a USB keyboard or a USB mouse, see section 4.3.

1. Press one of the **CH1** to **CH8/4** keys to select the channel. The CH menu appears.
You can select up to channel CH4 and CH8 on the DL7440 and DL7480, respectively.
2. Press the **Position** soft key.
3. Turn the **jog shuttle** to set the vertical position.

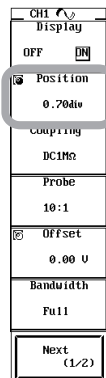

Explanation

Range of Movement

The vertical position can be moved within a range of ± 4 divisions from the center of the waveform display frame.

Resolution

0.01 divisions

Confirming the Vertical Position

For input waveforms and computed waveforms, the ground level and vertical position are marked to the left of the waveform display frame.

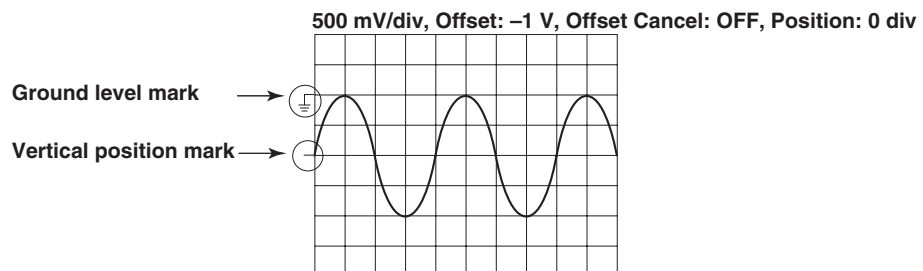

Note

- The waveform data that goes off the waveform display frame from moving the vertical position is handled as overflow data.
- If the display waveform goes out of the waveform display frame from moving the vertical position during waveform acquisition, a chopped waveform is displayed as shown in the following figure even if the vertical position is returned to its original position after stopping the acquisition.

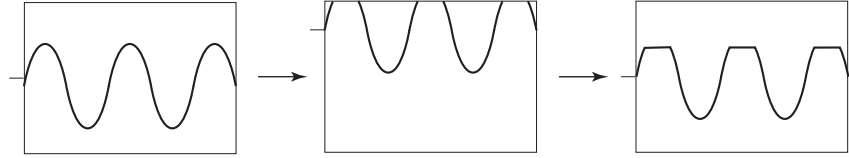

- Changing the vertical position also changes the valid data range. For details, see page 2-2.

5.4 Setting the Input Coupling

<For a description of this function, refer to page 2-3.>

Procedure

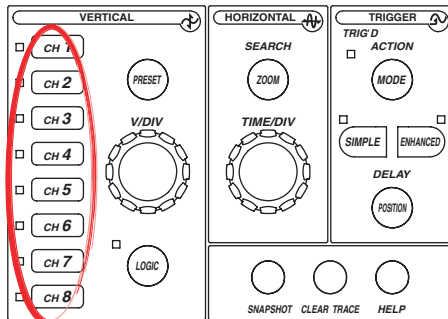

- To exit the menu during operation, press **ESC** located above the soft keys.
- For a description of the operation using a USB keyboard or a USB mouse, see section 4.3.

1. Press one of the **CH1** to **CH8/4** keys to select the channel. The CH menu appears.
You can select up to channel CH4 and CH8 on the DL7440 and DL7480, respectively.
2. Press the **Coupling** soft key. The Coupling menu appears.
3. Press the soft key corresponding to the desired coupling.
If DC50Ω is selected, a menu used to confirm the execution appears. Press the Set to DC50Ω or Cancel soft key.

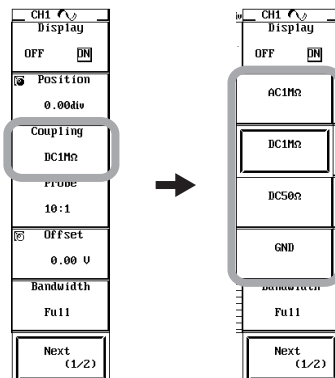

Explanation**Selecting the Input Coupling**

You can select the method of coupling the input signal to the vertical control circuit.

AC1M Ω

Acquires and displays only the AC component of the input signal.

DC1M Ω

Acquires and displays all the components (DC and AC) of the input signal (1-M Ω input).

DC50 Ω

Acquires and displays all the components (DC and AC) of the input signal (50- Ω input).

GND

Checks the ground level.

Input Coupling and Frequency Characteristics

Below are the frequency characteristics for the cases when AC1M Ω , DC50 Ω , and DC1M Ω are selected. Note that when AC1M Ω is selected, low frequency signals or signal components are not acquired (as shown in the figure below).

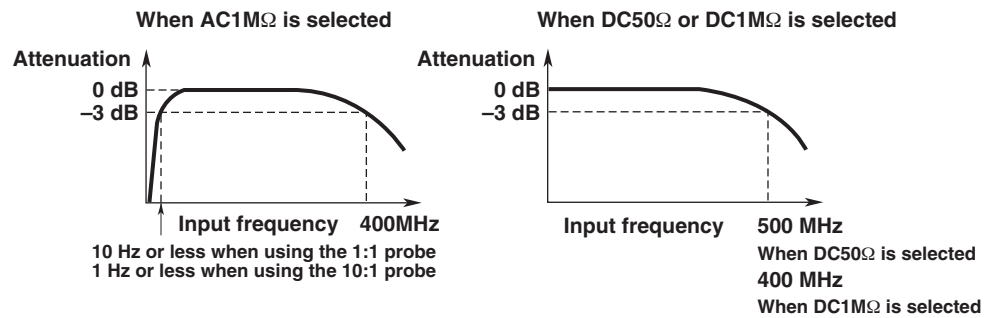
**CAUTION**

The maximum input voltage when the frequency is less than or equal to 1 kHz is 400 V (DC+ACpeak) for 1-M Ω input and 5 Vrms or 10 Vpeak for 50- Ω input. Applying a voltage exceeding either of the two values can damage the input section. If the frequency is above 1 kHz, damage may occur even when the voltage is below this value.

5.5 Selecting the Probe Attenuation/Current-to-Voltage Conversion Ratio

<For a description of this function, refer to page 2-3.>

Procedure

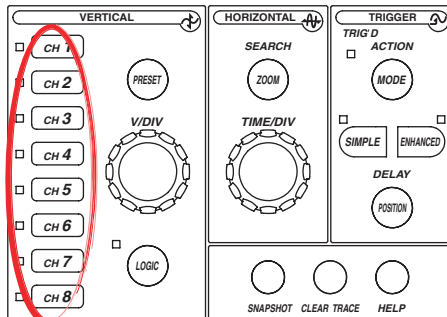

- To exit the menu during operation, press **ESC** located above the soft keys.
- For a description of the operation using a USB keyboard or a USB mouse, see section 4.3.

1. Press one of the **CH1** to **CH8/4** keys to select the channel. The CH menu appears.
You can select up to channel CH4 and CH8 on the DL7440 and DL7480, respectively.
2. Press the **Probe** soft key. The Probe menu appears.
3. Press the soft key corresponding to the desired attenuation/current-to-voltage conversion ratio.

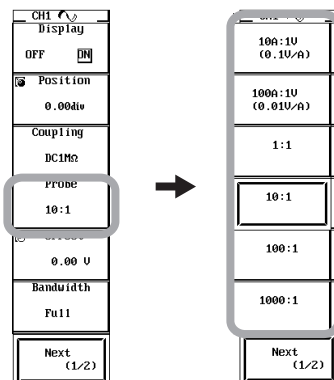

Explanation

You can select the attenuation or the current-to-voltage conversion ratio of the probe of each channel according to the probe being used from the following.

1:1, 10:1, 100:1, 1000:1, 10 A:1 V (0.1 V/A), or 100 A:1 V (0.01 V/A)

- 1:1 to 1000:1 are probe attenuation settings.
- 10 A:1 V (0.1 V/A) and 100 A:1 V (0.01 V/A) are probe current-to-voltage conversion ratio settings. The model name of the supported current probe is indicated inside the parentheses.

Note

If the attenuation or the current-to-voltage conversion ratio is not set correctly, the voltage and scale values of the input signals will not be displayed correctly. For example, if you set the attenuation to 1:1 when you are actually using a 10:1 probe, the displayed value for the waveform amplitude will be 1/10th the actual value.

5.6 Setting the Offset Voltage

<For a description of this function, refer to page 2-4.>

Procedure

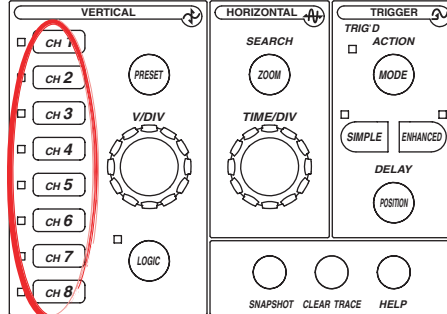

- To exit the menu during operation, press **ESC** located above the soft keys.
- For a description of the operation using a USB keyboard or a USB mouse, see section 4.3.

Setting the Offset Voltage

1. Press one of the **CH1** to **CH8/4** keys to select the channel.
You can select up to channel CH4 and CH8 on the DL7440 and DL7480, respectively.
2. Press the **Offset** soft key.
3. Turn the **jog shuttle** to set the offset voltage.

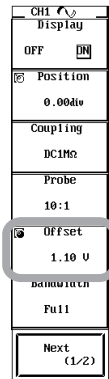

Resetting the Offset Voltage

4. Press **RESET**. The offset voltage is set to 0 V.

Explanation

The offset voltage applies to all input couplings.

Selectable Range of Offset Voltage

Voltage Axis Sensitivity (Probe = 1:1)	Offset Voltage Selectable Range
2 mV/div to 50 mV/div	-1.0 V to 1.0 V
0.1 V/div to 0.5 V/div	-10.0 V to 10.0 V
1 V/div to 10 V/div	-100.0 V to 100.0 V (except 1 V/div only for DC50Ω)

- 1 The resolution is 0.01 divisions. For 2 mV/div, the resolution is 0.02 mV.
- 2 The values are 10 times, 100 times, and 1000 times the values shown above when the probe attenuation is 10:1, 100:1, and 1000:1, respectively. If the probe current-to-voltage conversion ratio is 10 A: 1 V, the values are the same 10 times the values shown above with the unit changed to A. If the ratio is 100 A: 1 V, the values are 100 times the values shown above with the unit changed to A.

Resetting the Offset Value

Pressing the **RESET** key resets the offset value to 0 V.

5.6 Setting the Offset Voltage

Note

- Only the waveform display position changes when acquisition is stopped. The new offset voltage is applied to the acquired data the next time waveform acquisition is started.
 - You can select whether to apply the offset voltage to cursor measurement values, automated measurement values of waveform parameters, and computation. See section 15.3.
 - If you change the probe attenuation, the offset changes proportionally to reflect the new attenuation rate.
 - If you change the vertical axis sensitivity after setting the offset value, the offset value does not change.
 - The selectable range and resolution of the offset value vary depending on the vertical axis sensitivity setting. The behavior when you change the vertical axis sensitivity after setting the offset value is indicated below. If you change the vertical axis sensitivity back to the original setting without changing the offset value, the original offset value returns.
 - When the vertical axis sensitivity is increased (the value is decreased) and the specified offset value exceeds the selectable range of the offset voltage at the new vertical axis sensitivity, the offset voltage is set to the maximum value of the selectable range of the offset value at the new vertical axis sensitivity.
 - When the vertical axis sensitivity is decreased (the value is increased) and the specified resolution of the offset value falls below the resolution of the offset value at the new vertical axis sensitivity, the resolution is set to the resolution of the offset voltage at the new vertical axis sensitivity.
-

5.7 Using the Preset Function

Procedure

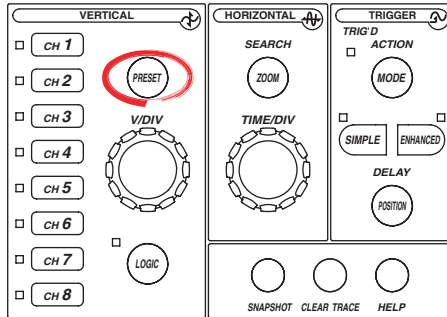

- To exit the menu during operation, press **ESC** located above the soft keys.
- For a description of the operation using a USB keyboard or a USB mouse, see section 4.3.

Selecting the Channels to Be Preset

1. Press **PRESET**. The PRESET menu appears.
2. Press the **Select** soft key. The Select menu appears.
3. Press the **CH1 to CH8/4** soft key to select the channel for setting the preset. Pressing All will select all the channels. You can select up to CH4 and CH8 on the DL7440 and DL7480, respectively. CH6 to CH8 appear when you press the To Page 2 soft key.

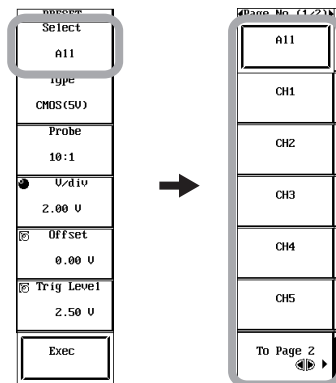

Selecting the Preset Type

4. Press the **Type** soft key. The Type menu appears.
5. Press the **CMOS(5V)**, **CMOS(3.3V)**, **ECL**, or **User** soft key.

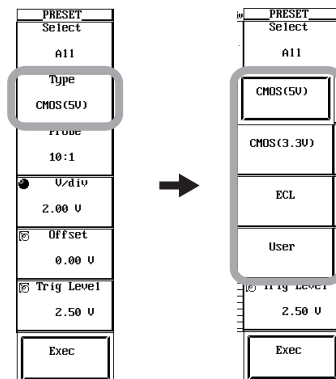

5.7 Using the Preset Function

Selecting the Probe Attenuation/Current-to-Voltage Conversion Ratio

6. Press the **Probe** soft key. The Probe menu appears.
7. Press the soft key corresponding to the desired attenuation/current-to-voltage conversion ratio.

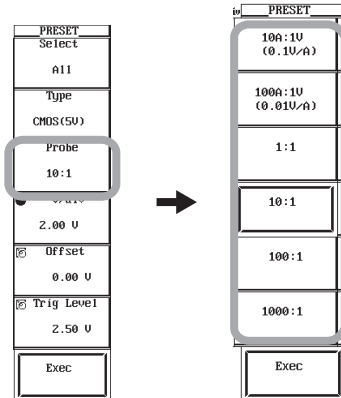

Proceed to step 12 unless USER type is selected.

Setting the V/div Value, Offset Voltage, and Trigger Type under USER

8. Press the **V/div** soft key.
9. Turn the **jog shuttle** to set the V/div value.
10. Press the **Offset** or **Trigger Level** soft key.
11. Turn the **jog shuttle** to set the offset voltage or trigger level.

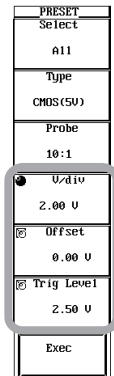

Executing the Preset Operation

12. Press the **Exec** soft key. Preset is executed.

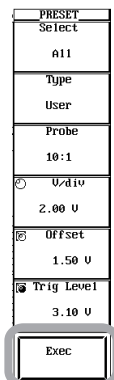

Explanation

The key settings of V/div, input coupling, trigger level, and other items are automatically set to the optimum values (or arbitrary values) for the CMOS signal or ECL signal. You can also automatically set to the optimum values for the current probe 700937, 701930 or 701931 (sold separately). You can set each channel separately or set all the channels to the same settings.

Setup after Executing Preset

Preset type	CMOS(5V)	CMOS(3.3V)	ECL	User
Input coupling	DC1M Ω	DC1M Ω	DC1M Ω	DC1M Ω
Trigger coupling	DC	DC	DC	DC
Probe	Select from 1:1, 10:1, 100:1, 1000:1, 10A:1V (0.1V/A), and 100A:1V (0.01V/A)			
V/div	2 V/div	1 V/div ¹	200 mV/div ¹	Arbitrary ²
Offset voltage	0 V	0 V	-1.3 V	Arbitrary ²
Trigger level	2.5 V	1.65 V	-1.3 V	Arbitrary ²

1 2 V/div (2 A/div) for 1000:1

2 For the selectable ranges, see section 5.2, "Setting V/div," 5.6, "Setting the Offset Voltage," and 6.5, "Setting the Edge Trigger (SIMPLE)."

5.8 Setting Bandwidth Limits

Procedure

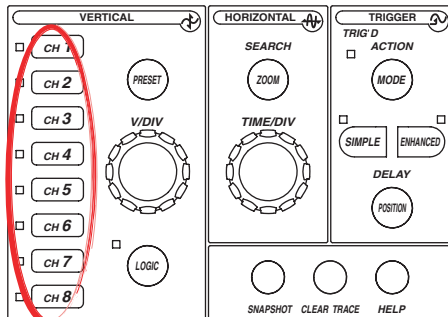

- To exit the menu during operation, press **ESC** located above the soft keys.
- For a description of the operation using a USB keyboard or a USB mouse, see section 4.3.

1. Press one of the **CH1** to **CH8/4** keys to select the channel. The CH menu appears.
You can select up to channel CH4 and CH8 on the DL7440 and DL7480, respectively.
2. Press the **Bandwidth** soft key. The Bandwidth menu appears.
3. Press the **20MHz**, **100MHz**, or **Full** soft key.
4. As necessary, repeat steps 1 to 3.

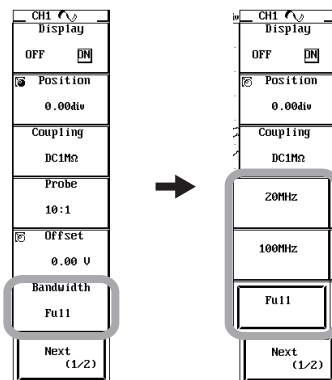

Note

The bandwidth limit is set for each channel. Set the bandwidth limit for all necessary channels.

Explanation

Bandwidth limits for 20 MHz and 100 MHz are available. The frequency characteristics when bandwidth is limited are shown below. If you select Full, the bandwidth limit is 500 MHz (50-Ω input) or 400 MHz (1-MΩ input).

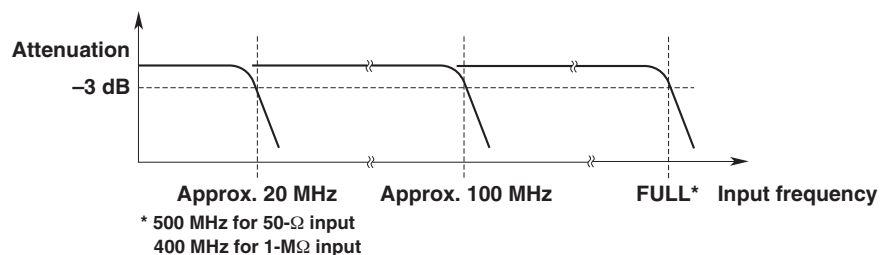

5.9 Using the Linear Scaling Function

<For a description of this function, refer to page 2-4.>

Procedure

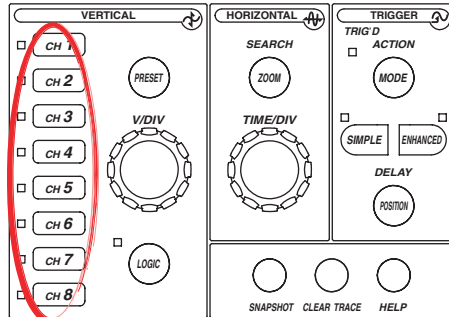

- To exit the menu during operation, press **ESC** located above the soft keys.
- For a description of the operation using a USB keyboard or a USB mouse, see section 4.3.

1. Press one of the **CH1** to **CH8/4** keys to select the channel. The CH menu appears.
You can select up to channel CH4 and CH8 on the DL7440 and DL7480, respectively.
2. Press the **Next (1/2)** soft key
3. Press the **Linear Scale AX+B** soft key to select ON.
4. Press the **A/B** soft key to set the jog shuttle control to A.
5. Turn the **jog shuttle** to set the A value.
6. Likewise, set the B value.
7. To attach a unit, press the **Unit** soft key to display the keyboard and enter the unit name.

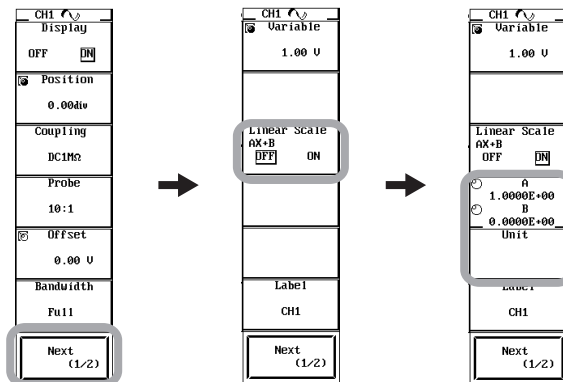

Note

- Linear scaling is not available for the following waveforms.
 - Snapshot waveforms
 - Accumulated waveforms (however, linear scaling is possible on the accumulated waveform acquired last.)
- Linear scaling is set for each channel.
- The scaling coefficient A and offset value B that you entered are held even if you turn OFF the linear scaling function.
- Computation is performed using the linear scaling results.

5.9 Using the Linear Scaling Function

Explanation

The computation shown below is executed using the specified coefficient A and offset B. The cursor measurement values and automated measurement values of waveform parameters are displayed using the scaled values. A unit can be attached to the scaled values.

$Y = AX + B$ (where X is the measured value and Y is the linear scaling result)

Setting Scaling Coefficient A and Offset Value B

Selectable range of A and B	-9.9999E+30 to +9.9999E+30
Default settings	A 1.0000E+00
	B 0.0000E+00

Setting the Unit

You can set the unit using up to four alphanumeric characters.

Displaying the Scale Value

The upper and lower limits of the vertical axis of each channel can be displayed using scaled values (scale values). For the procedure of displaying scale values, see section 8.8.

5.10 Turning ON/OFF the Logic Input and Setting the Threshold Level

Procedure

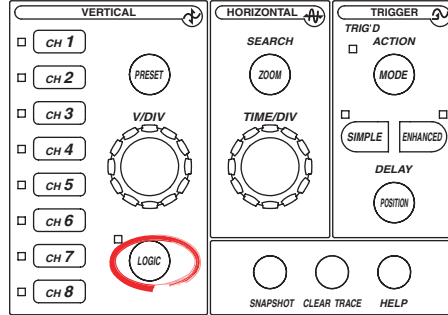

- To exit the menu during operation, press **ESC** located above the soft keys.
- In the procedural explanation below, the term *jog shuttle* & *SELECT* refers to the operation of selecting/setting items and entering values using the **jog shuttle** and **SELECT** and **RESET** keys. For details on this operation, see sections 4.1 or 4.2.
- For a description of the operation using a USB keyboard or a USB mouse, see section 4.3.

Turning ON/OFF the Logic Input

1. Press **LOGIC**. The LOGIC menu appears.
2. Press the **Mode** soft key to select ON or OFF.

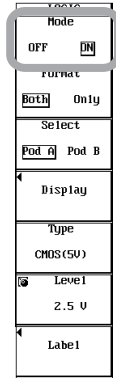

Selecting the Target Pod

3. Press the **Select** soft key to select Pod A or Pod B.

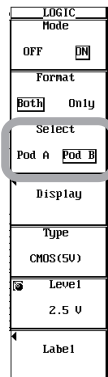

5.10 Turning ON/OFF the Logic Input and Setting the Threshold Level

Turning ON/OFF Each Bit

4. Press the **Display** soft key. The Display dialog box appears.
5. Use the **jog shuttle** to select the bit, and then press **SELECT** to select ON or OFF.
 - The input is turned ON when the mark to the left of the bit is highlighted.
 - If All ON is selected, the input of all the bits is turned ON.
 - If All OFF is selected, the input of all the bits is turned OFF.

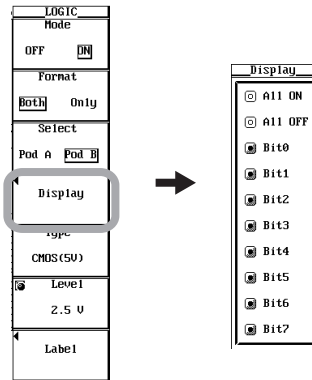

Setting the Threshold Level

6. Press the **Type** soft key to select CMOS(5V), CMOS(3.3V), ECL, or User.
7. If you selected User, use the **jog shuttle** to set the threshold level.
If you change the threshold level using the jog shuttle even if a setting other than User is selected at step 6, Type is automatically set to User.

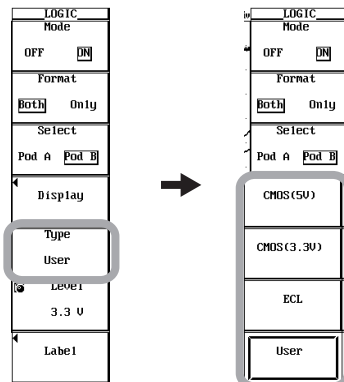

8. Press **ESC** to close the dialog box.

Setting Labels

9. Press the **Label** soft key. A Label dialog box opens.
10. Use **jog shuttle & SELECT** to select the target bit. A keyboard appears.
11. Use the keyboard to enter the waveform label.
12. Repeat steps 9 and 10 as necessary.
13. Press **ESC** to close the dialog box.

5.10 Turning ON/OFF the Logic Input and Setting the Threshold Level

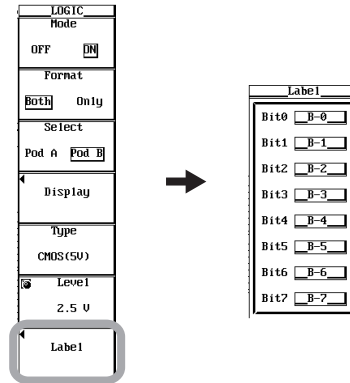

Explanation

Each bit of the optional logic input can be turned ON/OFF, and the threshold level can be specified.

Turning ON/OFF the Logic Input

If you turn ON the logic input, a logic waveform display frame opens.

Note

To display the logic waveform display frame on a full screen, press the Format soft key and select Only (see section 8.1).

Selecting the Bits to Be Displayed

You can specify the bits to be displayed on each pod. If all the bits of either POD A or POD B are turned OFF, the vertical display range of the other pod is expanded.

Threshold Level

You can select the threshold level of the input signal for each pod.

CMOS(5V)	2.5 V
CMOS(3.3V)	1.6 V
ECL	-1.3 V
User	User-defined setting
	Selectable range: ± 40 V when using the 701980 Logic Probe, ± 10 V when using the 701981 Logic Probe
	Resolution: 0.1 V

Assigning the Waveform Labels

You can set a waveform label for each bit using up to 8 characters.

Note

- If the acquisition mode is set to Average or Box Average while using the logic input, average or box average applies only to analog waveforms.
- If interleave mode is turned ON, Pod B cannot be used.
- The threshold level for the external clock input and the trigger level for the external trigger input are common.

5.11 Selecting the Time Base

<For a description of this function, refer to page 2-5.>

Procedure

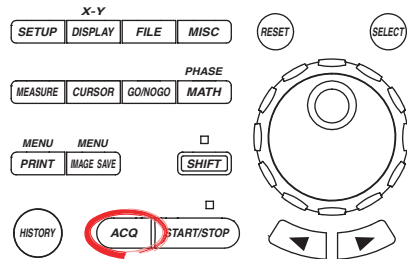

- To exit the menu during operation, press **ESC** located above the soft keys.
- For a description of the operation using a USB keyboard or a USB mouse, see section 4.3.

Selecting the Time Base

1. Press **ACQ**. The ACQ menu appears.
2. Press the **Time Base** soft key to select Int or Ext.

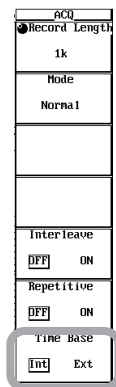

Setting the Threshold Level When Using an External Clock

3. Press **SIMPLE**. In the menu appears, set the trigger source to EXT and set the level.

This operation is common with the trigger level settings. For details on the procedure, see section 6.6.

Explanation**Selecting the Time Base**

You can select the time base that is used as a timing reference for acquiring waveform data.

Int	Internal clock signal
Ext	Clock signal applied to the external clock input terminal

When Setting the External Clock Signal as the Time Base

Apply a clock signal of the following specifications to the EXT CLOCK IN/EXT TRIG IN/TRIG GATE IN terminal (shared with the external trigger input) on the rear panel.

Item	Specifications
Connector type	BNC
Maximum allowable input voltage	± 40 V (DC+ACpeak) or 28 Vrms when the frequency is 10 kHz or less
Input frequency range	40 Hz to 20 MHz (continuous clock only)
Sampling jitter	± 1.25 ns or less
Minimum input amplitude	0.1 Vp-p
Input impedance	Approx. 1 M Ω , approx. 22 pF
Threshold level	± 2 V (resolution is 5 mV)
Minimum pulse width	10 ns or more for high and low

External Clock Input Terminal**CAUTION**

Applying a voltage that exceeds the maximum allowable input voltage indicated above to the EXT CLOCK IN/EXT TRIG IN/TRIG GATE IN terminal can damage the input section.

Note

- The clock signal must be a continuous clock signal. Burst signals cannot be applied.
- Only realtime sampling mode can be used.
- You cannot set the acquisition mode to Envelope or Box Average.
- You cannot display waveforms in roll mode.
- No function is provided for frequency-dividing the clock signal.
- Since the time axis setting cannot be changed, zoom in/out of the time axis when you wish to change the display range of the time axis. For the zoom procedure, see section 8.4.
- You cannot set a trigger delay.
- You cannot use the deskew function.
- The time measured by the cursor measurement or automated measurement of waveform parameters is expressed in the number of pulses of the clock signal. No unit is displayed.
- The threshold level for the external clock input and the trigger level for the external trigger input are common.

5.12 Setting T/div

<For a description of this function, refer to page 2-5.>

Procedure

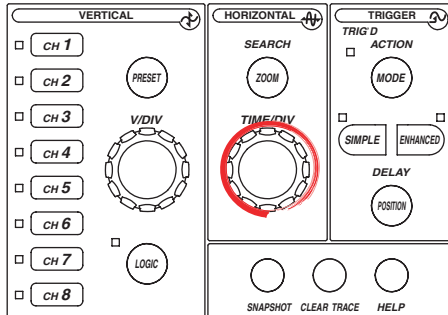

- To exit the menu during operation, press **ESC** located above the soft keys.
- For a description of the operation using a USB keyboard or a USB mouse, see section 4.3.

Turn the **TIME/DIV** knob to set the T/div.

Note

If the TIME/DIV knob is turned while the waveform acquisition is stopped, the new T/div value is displayed inside the parentheses at the upper right corner of the screen. The new T/div value becomes valid the next time waveform acquisition is started.

Explanation

Selectable T/div Range

- 1 ns/div to 50 s/div in 1-2-5 steps (when the record length is 10 kW or more)
- 1 ns/div to 5 s/div in 1-2-5 steps (when the record length is 1 kW)

T/div and Sampling Mode

The maximum sample rate when repetitive sampling is OFF (see section 7.4) is 1 GS/s (2 GS/s when interleave mode is ON). In repetitive sampling mode, data can be sampled at 2 GS/s (5 GS/s when interleave mode is ON) to 100 GS/s. However, the time axis settings that allow repetitive sampling mode vary depending on the model and settings such as the record length. For details, see appendix 1.

Note

When you change the T/div setting, repetitive sampling mode may be automatically enabled even when repetitive sampling is set to OFF (see appendix 1).

T/div and Roll Mode

Under the following conditions, roll mode display is enabled for the T/div settings listed below.

- Acquisition mode is set to a mode other than averaging.
- Acquisition count is set to infinite.
- The trigger mode is set to auto, auto level, or single.

Record Length	T/div
1 kW	50 ms/div to 5 s/div
10 k to 1 MW	50 ms/div to 50 s/div
2 MW	100 ms/div to 50 s/div
4 MW	200 ms/div to 50 s/div
8 MW	500 ms/div to 50 s/div
16 MW	1 s/div to 50 s/div

6.1 Selecting the Trigger Mode

<For a description of this function, refer to page 2-12.>

Procedure

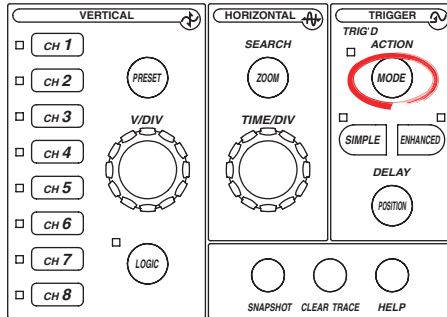

- To exit the menu during operation, press **ESC** located above the soft keys.
- For a description of the operation using a USB keyboard or a USB mouse, see section 4.3.

1. Press **MODE**. The MODE menu appears.
2. Press the soft key corresponding to the desired mode.
For the procedure of selecting Single(N), see section 7.6.

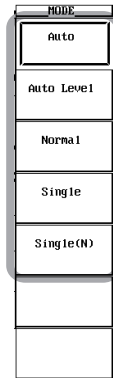

Explanation

Auto Mode

If the trigger condition is met within the 100-ms timeout period, the waveform is updated on each trigger occurrence. If the trigger condition is not met after the timeout period elapses, the waveform is automatically updated. If the time axis setting is in the range in which the display mode is set to roll mode, the display is set to roll mode (see page 2-7).

Auto Level Mode

If a trigger occurs within the timeout period, the waveform is displayed in the same fashion as in auto mode. If a trigger is not activated within the timeout period, then the center value of the amplitude of the trigger source is detected, and the trigger level is changed to that value. A trigger is activated using the new value, and the displayed waveforms are updated. Auto-level mode is valid only if the trigger is a simple trigger and the trigger source is between CH1 and CH8/4*. For all other cases, the operation is the same as for auto mode. If the time axis setting is in the range in which the display mode is set to roll mode, the display is set to roll mode.

* You can select up to CH4 and CH8 on the DL7440 and DL7480, respectively.

Normal Mode

The display is updated only when the trigger conditions are met. The display is not updated if the trigger does not occur. Therefore, to check the waveform or ground level when no trigger is detected, use auto mode.

Single Mode

The display is updated once when the trigger conditions are met and the waveform acquisition stops. In the time axis setting range in which the display is set to roll mode, the display is set to roll mode. When a trigger occurs, the specified record length of data is acquired and the displayed waveform stops.

Single (N) Mode

Select this mode when acquiring waveforms using the sequential store function. For the procedure of selecting this mode, see section 7.6.

Note

The trigger mode setting applies to both simple and enhanced triggers.

6.2 Setting the Trigger Position

<For a description of this function, refer to page 2-13.>

Procedure

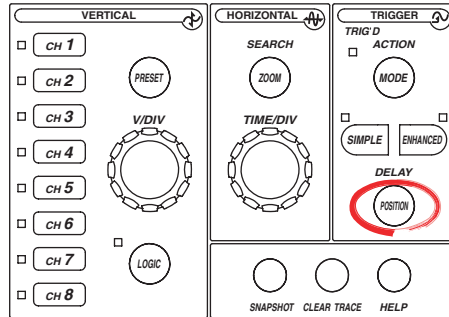

- To exit the menu during operation, press **ESC** located above the soft keys.
- For a description of the operation using a USB keyboard or a USB mouse, see section 4.3.

1. Press **POSITION**. The POSITION menu appears.
2. Turn the **jog shuttle** to set the trigger position.
 - If you wish to select 10%, 50%, or 90%, you can press the corresponding soft key.
 - Pressing RESET resets the number to 50%.

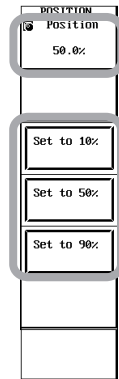

Explanation

Trigger Position

Trigger position = Trigger point + trigger delay

You can select the location of the trigger position on the screen. If the trigger delay is 0 s, the trigger position and the trigger point match. For the operating procedure of the trigger delay, see section 6.3.

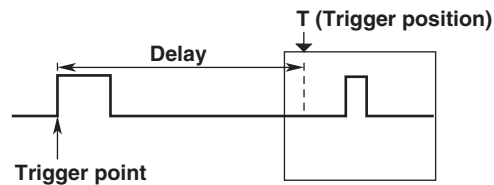

Selectable Range of Trigger Position

The trigger position can be set in the range of 0 to 100% (resolution is 0.1%) taking the display record length (see appendix 1) to be 100%.

Display the Trigger Position

A mark that appears at the top of the screen indicates the trigger position with respect to the display record length.

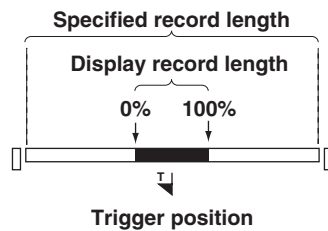

Note

- If you change the trigger position while waveform acquisition is stopped, the new setting will not become effective until acquisition is started and the waveform is updated.
 - Note that cursor time measurements are with respect to the trigger position. Changing the trigger position therefore changes the measurement values (except when in roll mode display).
 - If you change the T/div setting, the time axis setting is rescaled with respect to the trigger position.
-

6.3 Setting the Trigger Delay

Procedure

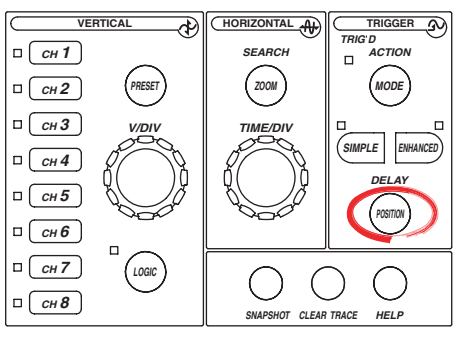

- To exit the menu during operation, press **ESC** located above the soft keys.
- For a description of the operation using a USB keyboard or a USB mouse, see section 4.3.

1. Press **SHIFT+POSITION(DELAY)**. The DELAY menu appears.
2. Press the soft key corresponding to the desired time unit.
If you are not specifying a time unit (ms, us, ns, or ps), press the DELAY soft key.
3. Turn the **jog shuttle** to set the delay.
Pressing RESET resets the value to 0 s.

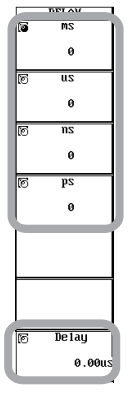

Explanation

Although the display usually shows the waveform before and after the trigger point, it is possible to display the acquired waveform after a fixed time period elapses using the trigger delay.

Selectable Range of Delay

0 to 4 s (resolution is (1/sample rate)/10))

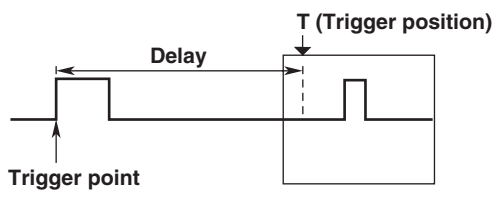

Note

- When T/div is changed, the delay remains unchanged.
- If the time base is set to external clock, the trigger delay cannot be specified (delay is fixed 0 s).

6.4 Setting the Hold Off Time

Procedure

For Simple Triggers

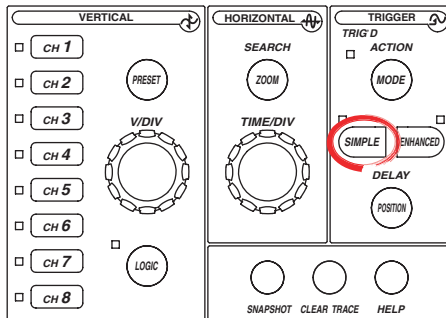

- To exit the menu during operation, press **ESC** located above the soft keys.
- For a description of the operation using a USB keyboard or a USB mouse, see section 4.3.

1. Press **SIMPLE**. The SIMPLE (Edge) menu appears.
2. Press the **Hold Off** soft key.
3. Turn the **jog shuttle** to set the hold off time.
Pressing RESET resets the value to 0.08 us.

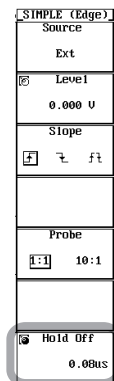

For Enhanced Triggers

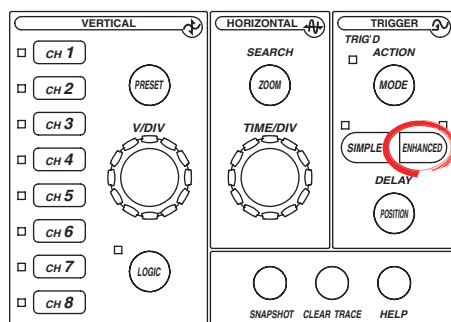

- To exit the menu during operation, press **ESC** located above the soft keys.
- For a description of the operation using a USB keyboard or a USB mouse, see section 4.3.

1. Press **ENHANCED**. The ENHANCED menu appears.
2. Press the **Hold Off** soft key.
3. Turn the **jog shuttle** to set the hold off time.
Pressing RESET resets the value to 0.08 us.

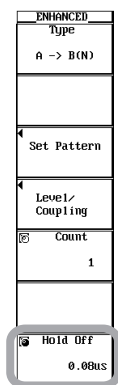
**Note**

The hold off time setting applies to both simple and enhanced triggers.

6.4 Setting the Hold Off Time

Explanation

As shown in the figure below, this setting prevents a trigger from being activated for a specified time, even when the trigger conditions are met during this time. This is useful when you wish to activate the trigger in sync with a periodic signal.

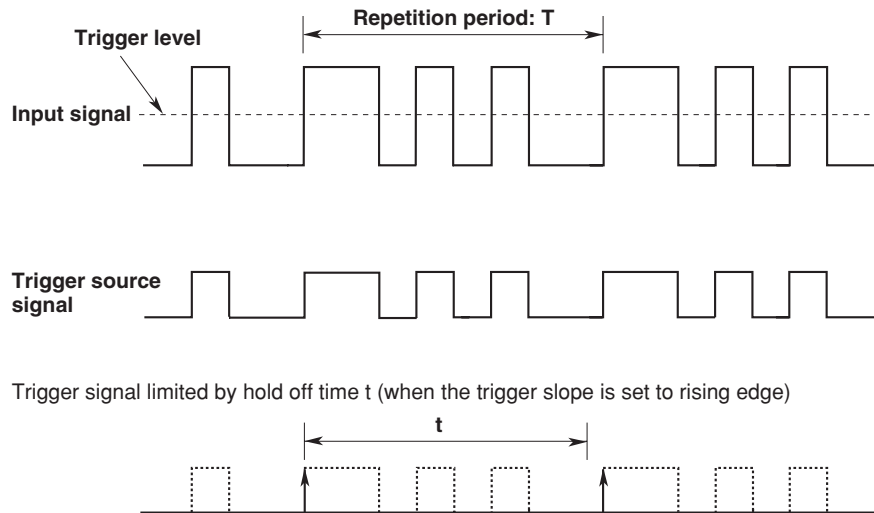

Selectable Range of the Hold Off Time

The selectable range is 80 ns to 10 s (the default value is 80 ns), and the resolution is 20 ns.

Note

- The updating of the waveform may slow down when using repetitive sampling. In such case, set the hold off time to a smaller value.
 - If you are setting the hold off time to 100 ms or greater, set the trigger mode to normal.
 - When used with A->B(N) or A Delay B trigger, the hold off time applies only to condition A.
-

6.5 Setting the Edge Trigger (SIMPLE)

<For a description of this function, refer to page 2-8.>

Procedure

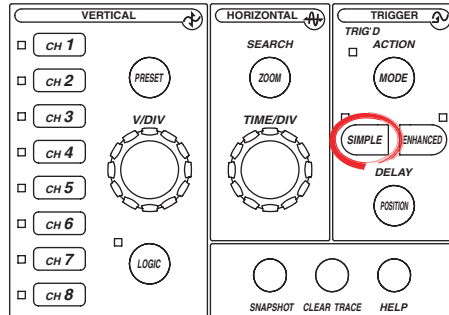

- To exit the menu during operation, press **ESC** located above the soft keys.
- For a description of the operation using a USB keyboard or a USB mouse, see section 4.3.

Setting the Trigger Source

1. Press **SIMPLE**. The SIMPLE (Edge) menu appears.
2. Press the **Source** soft key. The Source menu appears.
3. Press the soft key corresponding to the desired trigger source.
 - You can select up to channel CH4 and CH8 on the DL7440 and DL7480, respectively.
 - To set CH7 and CH8, press the To Page 2 soft key to display the page 2 menu.

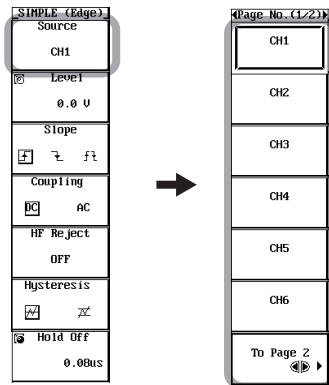

Setting the Trigger Level

4. Press the **Level** soft key.
5. Turn the **jog shuttle** to set the trigger level.
 - Pressing **RESET** resets the trigger level to the current offset voltage.

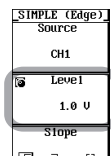

Note

The trigger level setting applies to both simple and enhanced triggers.

6.5 Setting the Edge Trigger (SIMPLE)

Setting the Trigger Slope

6. Press the **Slope** soft key to select \uparrow , \downarrow , or $\uparrow\downarrow$.

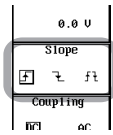

Setting the Trigger Coupling

7. Press the **Coupling** soft key to select DC or AC.

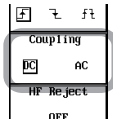

Note

The trigger coupling setting applies to both simple and enhanced triggers.

Setting the HF Rejection

8. Press the **HF Reject** soft key. The HF Reject menu is displayed.
9. Press the soft key corresponding to the desired frequency.

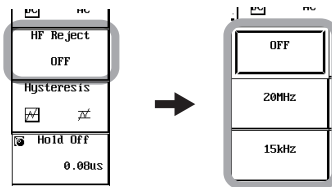

Note

The HF rejection setting applies to both simple and enhanced triggers.

Setting the Hysteresis

10. Press the **Hysteresis** soft key to select ∇ or ∇ .

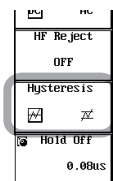

Note

The Hysteresis setting applies to both simple and enhanced triggers.

Setting the Hold Off

11. Set the hold off time according to the procedures given in section 6.4.

Explanation

This setting is used to activate a trigger when the input signal of a specified channel crosses the trigger level.

Trigger Source

You can select from CH1 to CH8/4. You can select up to channel CH4 and CH8 on the DL7440 and DL7480, respectively.



- For the procedure of setting the external signal applied to the EXT TRIG IN terminal on the rear panel as the trigger source (setting the trigger source to EXT), see section 6.6.
- For the procedure of activating the trigger in sync with the power supplied to the DL7400 (setting the trigger source to line), see section 6.7.

Trigger Level

- The selectable range is 8 divisions within the screen. The resolution is 0.01 divisions. For example, the resolution for 2 mV/div is 0.02 mV.
- You can also press the RESET key to reset the trigger level to the current offset voltage.

Trigger Slope

You can select how the trigger source signal is to cross the trigger level in activating the trigger.

	Activated when the trigger source changes from below the trigger level to above the trigger level (rising).
	Activated when the trigger source changes from above the trigger level to below the trigger level (falling).
	Activated on either a rising edge or falling edge.

Trigger Coupling

You can select the trigger coupling.



AC	Uses a signal that is obtained by removing the DC component from the trigger source signal.
DC	Uses the trigger source signal as-is.

HF Rejection

Set HF rejection to 15 kHz or 20 MHz if you wish to use a signal that is obtained by removing the high frequency components (frequency components greater than 15 kHz or 20 MHz) from the trigger source signal as the trigger source.

Hysteresis

Sets a width to the trigger level so that triggers are not activated by small changes in the trigger signal.

	Approximately 0.3 divisions* of hysteresis around the trigger level.
	Approximately 1 division* of hysteresis around the trigger level.

* The value above is an approximate value. It is not strictly warranted.

Hold Off

See section 6.4.

6.6 Setting the External Trigger (SIMPLE)

Procedure

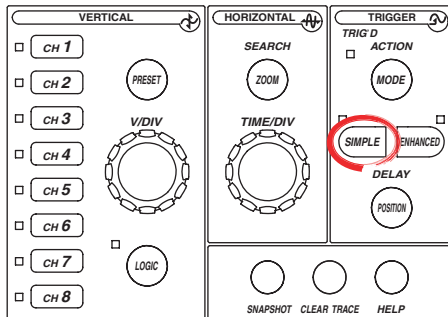

- To exit the menu during operation, press **ESC** located above the soft keys.
- For a description of the operation using a USB keyboard or a USB mouse, see section 4.3.

Setting the Trigger Source

1. Press **SIMPLE**. The SIMPLE (Edge) menu appears.
2. Press the **Source** soft key. The Source menu appears.
3. On the DL7480, press the **To Page 2** soft key.
4. Press the **Ext** soft key.

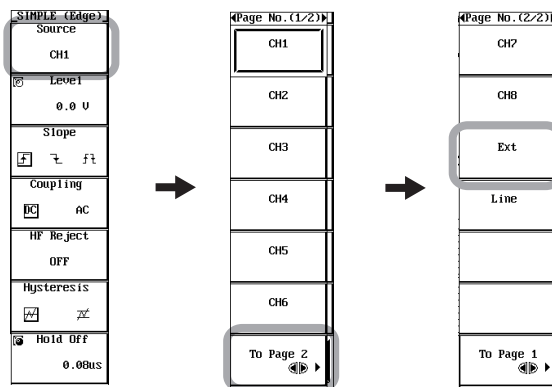

Setting the Trigger Level

4. Press the **Level** soft key.
5. Turn the **jog shuttle** to set the trigger level.
Pressing RESET resets the trigger level to 0 V.

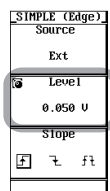

Setting the Trigger Slope

6. Press the **Slope** soft key to select **f**, **↕**, or **f↕**.

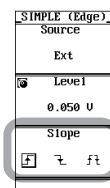

Setting the Probe Attenuation

7. Press the **Probe** soft key to select 1:1 or 10:1.

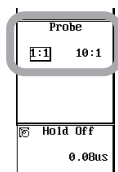
**Setting the Hold Off**

8. Set the hold off time according to the procedures given in section 6.4.

Explanation

The setting is for activating a trigger using the external signal applied to the EXT TRIG IN terminal on the rear panel of the DL7400.

Note

- For the specifications of the EXT TRIG IN terminal, see section 14.1.
- The threshold level for the external clock input and the trigger level for the external trigger input are common.

Trigger Source



Select Ext.

Trigger Level

The selectable range is ± 2 V, and the resolution is 5 mV.

Trigger Slope

You can select how the trigger source is to cross a specified level for activating the trigger.

- | | |
|---|--|
|  | Activated when the trigger source changes from below the trigger level to above the trigger level (rising). |
|  | Activated when the trigger source changes from above the trigger level to below the trigger level (falling). |
|  | Activated on either a rising edge or falling edge. |

Setting the Probe Attenuation

When connecting a probe to the EXT TRIG IN terminal and inputting the trigger signal, you can select the attenuation of the connected probe.

1:1, 10:1

Setting the Hold Off

See section 6.4.

6.7 Activating Triggers on the Commercial Power Supply (SIMPLE)

Procedure

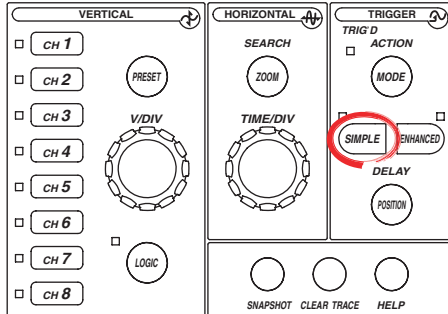

- To exit the menu during operation, press **ESC** located above the soft keys.
- For a description of the operation using a USB keyboard or a USB mouse, see section 4.3.

Setting the Trigger Source

1. Press **SIMPLE**. The SIMPLE (Edge) menu appears.
2. Press the **Source** soft key. The Source menu appears.
3. On the DL7480, press the **To Page 2** soft key.
4. Press the **Line** soft key.

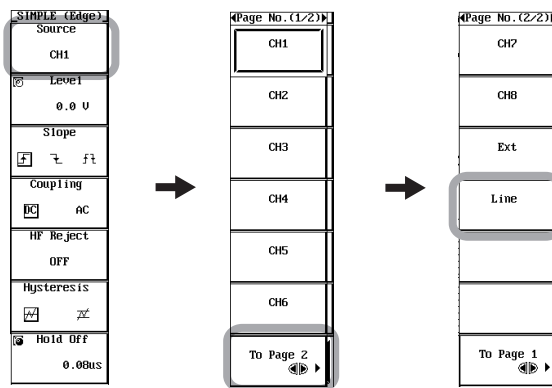

Setting the Hold Off

4. Set the hold off time according to the procedures given in section 6.4.

Explanation

This setting is used for activating a trigger on the rising edge of the waveform of the commercial power being supplied to the DL7400. Waveforms can be observed by synchronizing to the commercial power supply frequency (50 Hz or 60 Hz).

6.8 Setting the A->B(N) Trigger (ENHANCED)

<For a description of this function, refer to page 2-9.>

Procedure

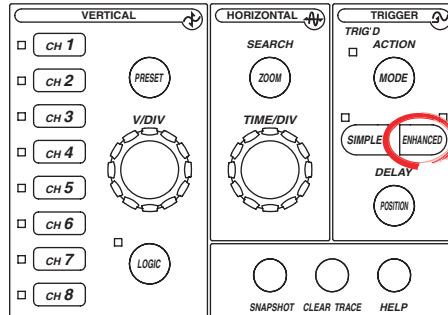

- To exit the menu during operation, press **ESC** located above the soft keys.
- In the procedural explanation below, the term *jog shuttle & SELECT* refers to the operation of selecting/setting items and entering values using the **jog shuttle** and **SELECT** and **RESET** keys. For details on this operation, see sections 4.1 or 4.2.
- For a description of the operation using a USB keyboard or a USB mouse, see section 4.3.

Setting the Trigger Type

1. Press **ENHANCED**. The ENHANCED menu appears.
2. Press the **Type** soft key. The Type menu appears.
3. Press the **A->B(N)** soft key.

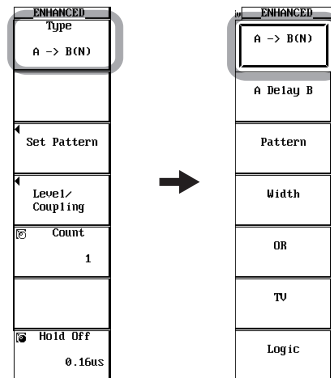

Setting the Status and Condition of Condition A and Condition B

4. Press the **Set Pattern** soft key. The Set Pattern dialog box opens.
5. Use **jog shuttle & SELECT** to set the status of condition A of each channel to H, L, or X.
6. Use **jog shuttle & SELECT** to set the condition of condition A to Enter or Exit.
7. Likewise, set condition B.

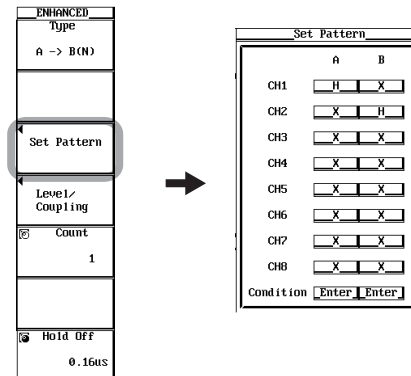

8. Press **ESC**. The Set Pattern dialog box closes.

6.8 Setting the A->B(N) Trigger (ENHANCED)

Setting the Level, Hysteresis, Trigger Coupling, and HF Rejection

9. Press the **Level/Coupling** soft key. The Level/Coupling dialog box opens.

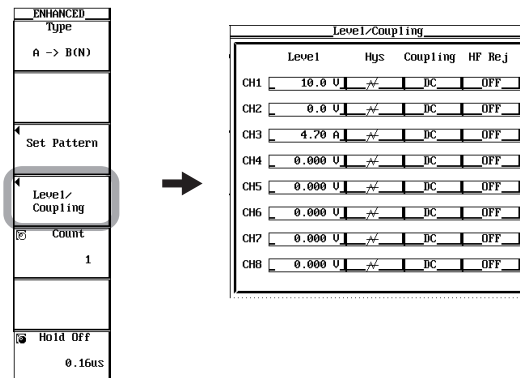

Setting the Level

10. Use **jog shuttle & SELECT** to set the level of each channel.

Setting the Hysteresis

11. Use **jog shuttle & SELECT** to set the hysteresis of each channel to ~~AC~~ or ~~AC~~.

Setting the Trigger Coupling

12. Use **jog shuttle & SELECT** to set the trigger coupling of each channel to DC or AC.

Setting the HF Rejection

13. Use **jog shuttle & SELECT** to set the HF rejection of each channel to OFF, 20MHz, or 15kHz.
14. Press **ESC**. The Level/Coupling dialog box closes.

Setting the Number of Times Condition B Is to Be Met

15. Press the **Count** soft key.
16. Turn the **jog shuttle** to set the count.
Pressing RESET resets the value to 1.

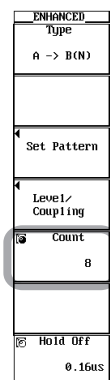

Setting the Hold Off

17. Set the hold off time according to the procedures given in section 6.4.

Note

- The status settings of conditions A and B apply to A->B(N) and A Delay B.
- The trigger level, hysteresis, trigger coupling, and HF rejection settings apply to both simple and enhanced triggers.

Explanation

This setting is for activating a trigger the Nth time condition B becomes true after condition A has become true.

Conditions A and B

You can select the status of each channel.

H	Above the preset trigger level
L	Below the preset trigger level
X	Don't Care

You can select the condition.

Enter	Trigger is activated when all channels match the specified condition.
Exit	Trigger is activated when any of the channels no longer match the specified condition.

Number of Times Pattern B Is to Be Met



You can set the value in the range of 1 to 10⁸.

Trigger Level

The selectable range is 8 divisions within the screen. The resolution is 0.01 divisions. For example, the resolution for 2 mV/div is 0.02 mV.

Hysteresis

Sets a width to the trigger level so that triggers are not activated by small changes in the trigger signal.

	Approximately 0.3 divisions* of hysteresis around the trigger level.
	Approximately 1 division* of hysteresis around the trigger level.

* The value above is an approximate value. It is not strictly warranted.

Trigger Coupling

You can select the trigger coupling.

AC	Uses a signal that is obtained by removing the DC component from the trigger source signal.
DC	Uses the trigger source signal as-is.

Turning ON/OFF the HF Rejection

Specify 15 kHz or 20 MHz if you wish to use a signal that is obtained by removing the high frequency components (frequency components greater than 15 kHz or 20 MHz) from the trigger source signal as the trigger source.

Hold Off

See section 6.4.

Note

If you wish to activate a trigger on a single pattern condition, use the pattern trigger (see section 6.10). If you specify Xs for all of the status of condition A or condition B, triggers will not be activated.

6.9 Setting the A Delay B Trigger (ENHANCED)

<For a description of this function, refer to page 2-9.>

Procedure

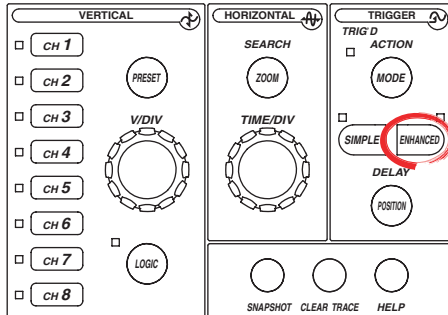

- To exit the menu during operation, press **ESC** located above the soft keys.
- In the procedural explanation below, the term *jog shuttle & SELECT* refers to the operation of selecting/setting items and entering values using the **jog shuttle** and **SELECT** and **RESET** keys. For details on this operation, see sections 4.1 or 4.2.
- For a description of the operation using a USB keyboard or a USB mouse, see section 4.3.

Setting the Trigger Type

1. Press **ENHANCED**. The ENHANCED menu appears.
2. Press the **Type** soft key. The Type menu appears.
3. Press the **A Delay B** soft key.

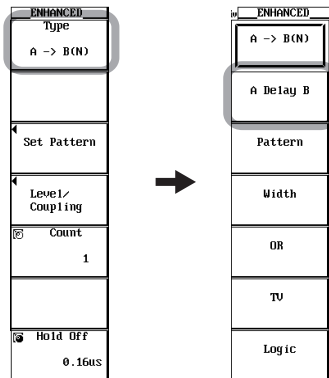

Setting the Status and Condition of Condition A and Condition B

4. Press the **Set Pattern** soft key. The Set Pattern dialog box opens.
5. Use **jog shuttle & SELECT** to set the status of condition A of each channel to H, L, or X.
6. Use **jog shuttle & SELECT** to set the condition of condition A to Enter or Exit.
7. Likewise, set condition B.

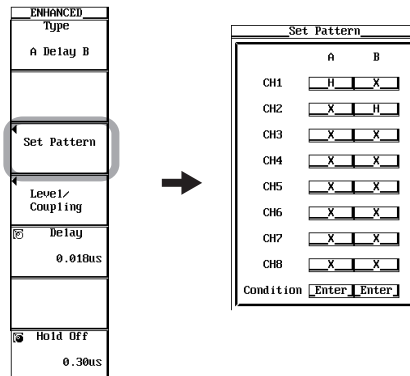

8. Press **ESC**. The Set Pattern dialog box closes.

Setting the Level, Hysteresis, Trigger Coupling, and HF Rejection

9. Press the **Level/Coupling** soft key. The Level/Coupling dialog box opens.
10. Like in the case of the A->B(N) trigger, set the level, hysteresis, trigger coupling, and HF rejection.

The setup procedure is common to the A->B(N) trigger. See page 6-16.

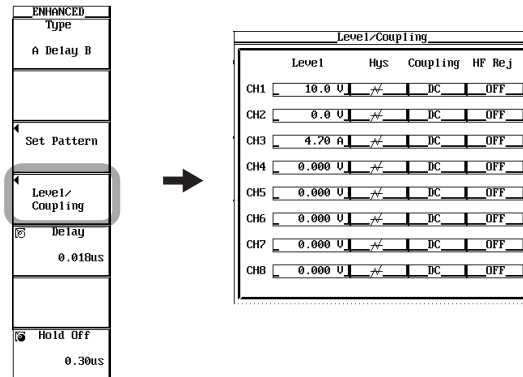

11. Press **ESC**. The Level/Coupling dialog box closes.

Setting the Delay

12. Press the **Delay** soft key.
13. Turn the **jog shuttle** to set the delay.
Pressing RESET resets the value to 0.003 μ s.

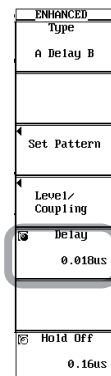
**Setting the Hold Off**

14. Set the hold off time according to the procedures given in section 6.4.

Note

- The status settings of conditions A and B apply to A->B(N) and A Delay B.
- The trigger level, hysteresis, trigger coupling, and HF rejection settings apply to both simple and enhanced triggers.

6.9 Setting the A Delay B Trigger (ENHANCED)

Explanation

This setting is for activating a trigger the first time condition B becomes true after condition A has become true and the preset time has elapsed.

Conditions A and B

You can select the status of each channel.

H	Above the preset trigger level
L	Below the preset trigger level
X	Don't Care

You can select the condition.

Enter	Trigger is activated when all channels match the specified condition.
Exit	Trigger is activated when any of the channels no longer match the specified condition.

Delay



3 ns to 5 s (resolution is 1 ns)

Trigger Level

The selectable range is 8 divisions within the screen. The resolution is 0.01 divisions. For example, the resolution for 2 mV/div is 0.02 mV.

Hysteresis

Sets a width to the trigger level so that triggers are not activated by small changes in the trigger signal.

	Approximately 0.3 divisions* of hysteresis around the trigger level.
	Approximately 1 division* of hysteresis around the trigger level.

* The value above is an approximate value. It is not strictly warranted.

Trigger Coupling

You can select the trigger coupling.

AC	Uses a signal that is obtained by removing the DC component from the trigger source signal.
DC	Uses the trigger source signal as-is.

Turning ON/OFF the HF Rejection

Specify 15 kHz or 20 MHz if you wish to use a signal that is obtained by removing the high frequency components (frequency components greater than 15 kHz or 20 MHz) from the trigger source signal as the trigger source.

Hold Off

See section 6.4.

Note

If you wish to activate a trigger on a single pattern condition, use the pattern trigger (see section 6.10). If you specify Xs for all of the status of condition A or condition B, triggers will not be activated.

6.10 Setting the Pattern Trigger (ENHANCED)

<For a description of this function, refer to page 2-10.>

Procedure

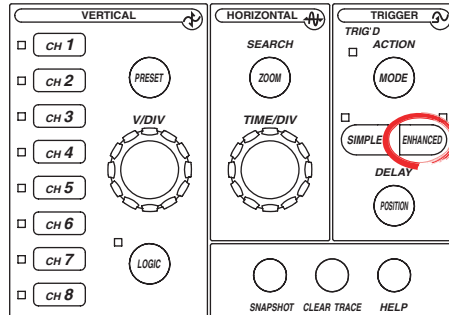

- To exit the menu during operation, press **ESC** located above the soft keys.
- In the procedural explanation below, the term *jog shuttle & SELECT* refers to the operation of selecting/setting items and entering values using the **jog shuttle** and **SELECT** and **RESET** keys. For details on this operation, see sections 4.1 or 4.2.
- For a description of the operation using a USB keyboard or a USB mouse, see section 4.3.

Setting the Trigger Type

1. Press **ENHANCED**. The ENHANCED menu appears.
2. Press the **Type** soft key. The Type menu appears.
3. Press the **Pattern** soft key.

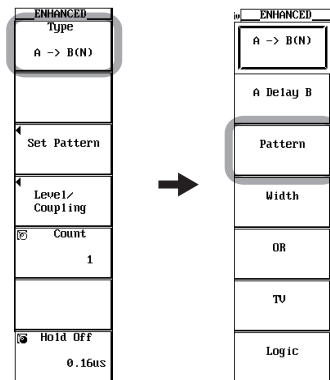

Setting the Status and Condition

4. Press the **Set Pattern** soft key. The Set Pattern dialog box opens.

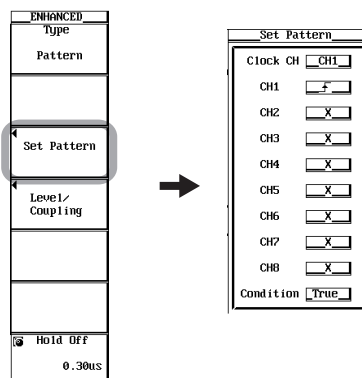

Activating a Trigger Only on the Status Pattern

5. Use **jog shuttle & SELECT** to set Clock CH to None.
6. Use **jog shuttle & SELECT** to set the status of each channel to H, L, or X.

6.10 Setting the Pattern Trigger (ENHANCED)

- Use **jog shuttle & SELECT** to set Condition to Enter or Exit.
Proceed to step 9.

Activating a Trigger in Synchronization with the Clock Channel

- Use **jog shuttle & SELECT** to set Clock CH to CH1 to CH8/4.
You can select up to channel CH4 and CH8 on the DL7440 and DL7480, respectively.
- Use **jog shuttle & SELECT** to set the trigger slope of the clock channel to \uparrow or \downarrow .
- Use **jog shuttle & SELECT** to set the status of each channel to H, L, or X.
- Use **jog shuttle & SELECT** to set Condition to True or False.
- Press **ESC**. The Set Pattern dialog box closes.

Setting the Level, Hysteresis, Trigger Coupling, and HF Rejection of the Clock CH

- Press the **Level/Coupling** soft key. The Level/Coupling dialog box opens.
- Like in the case of the A->B(N) trigger, set the level, hysteresis, trigger coupling, and HF rejection. The setup procedure is the same as the A->B(N) trigger. See page 6-16.

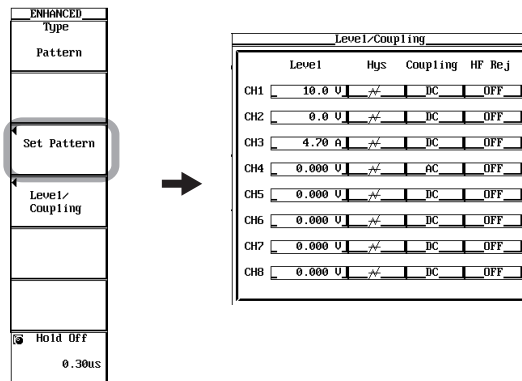

- Press **ESC**. The Level/Coupling dialog box closes.

Setting the Hold Off

- Set the hold off time according to the procedures given in section 6.4.

Note

The trigger level, hysteresis, trigger coupling, and HF rejection settings apply to both simple and enhanced triggers.

Explanation

This setting is for activating a trigger when all the conditions specified on multiple trigger sources are met or not met.

Trigger Status

You can select the trigger status of the trigger source.

H	When the trigger source level is above the specified trigger level
L	When the trigger source level is below the specified trigger level
X	Don't care

Clock Channel

You can select the synchronization signal for activating a trigger.

- Select "None" if the trigger is not to be activated in synchronization with the signal.
- To activate the trigger in synchronization with the signal, select CH1 or CH8/4 for the clock channel.
- You can select the trigger slope of the clock channel.

	Rising slope
	Falling slope

Trigger Condition

Activating a Trigger Only on the Status Pattern

You can select the condition for activating a trigger.

Enter	Activates a trigger when the specified combination (pattern) is met.
Exit	Activates a trigger when the specified pattern is no longer met.

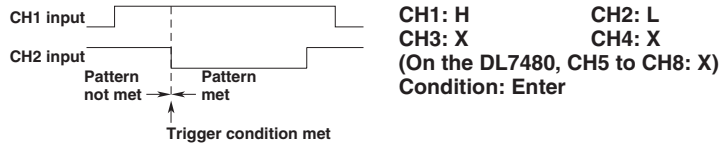

Activating a Trigger in Synchronization with the Clock Channel

You can select the condition for activating a trigger.

True	A trigger is activated on the rising or falling edge of the clock channel while the status pattern is met.
False	A trigger is activated on the rising or falling edge of the clock channel while the status pattern is not met.

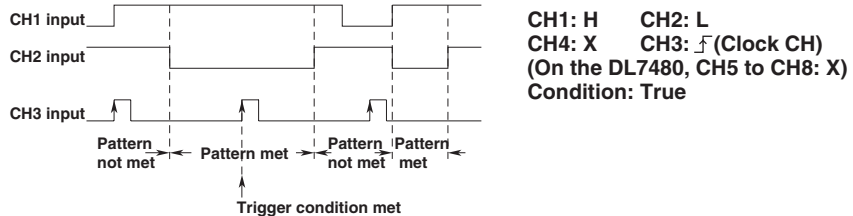

6.10 Setting the Pattern Trigger (ENHANCED)

Trigger Level

The selectable range is 8 divisions within the screen. The resolution is 0.01 divisions. For example, the resolution for 2 mV/div is 0.02 mV.

Hysteresis

Sets a width to the trigger level so that triggers are not activated by small changes in the trigger signal.

 Approximately 0.3 divisions* of hysteresis around the trigger level.

 Approximately 1 division* of hysteresis around the trigger level.

* The value above is an approximate value. It is not strictly warranted.

Trigger Coupling

You can select the trigger coupling.

AC Uses a signal that is obtained by removing the DC component from the trigger source signal.

DC Uses the trigger source signal as-is.

Turning ON/OFF the HF Rejection

Specify 15 kHz or 20 MHz if you wish to use a signal that is obtained by removing the high frequency components (frequency components greater than 15 kHz or 20 MHz) from the trigger source signal as the trigger source.

Hold Off

See section 6.4.

Note

- If you change the trigger type setting, the pattern trigger setting is disabled. However, if the trigger type is set to pattern trigger again, the previous setting is activated.
 - The operation is set to auto mode even when the trigger mode is set to auto level mode.
 - You can set the trigger status to all trigger sources. On the channel selected to be the clock channel, select the trigger slope.
 - If the setup time of the pattern against the clock signal is less than 1 ns or the hold time is less than 1 ns when activating a trigger in synchronization with the clock signal, the trigger may not operate properly.
-

6.11 Setting the Width (Pulse<Time, Pulse>Time, T1<Pulse<T2, and Time Out) Trigger (ENHANCED)

<For a description of this function, refer to page 2-10.>

Procedure

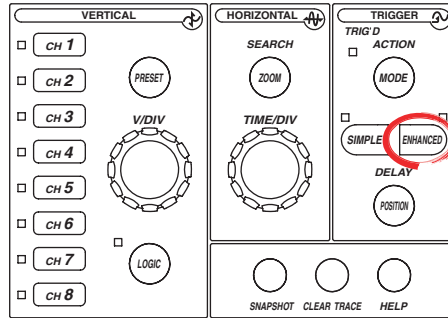

- To exit the menu during operation, press **ESC** located above the soft keys.
- In the procedural explanation below, the term *jog shuttle* & *SELECT* refers to the operation of selecting/setting items and entering values using the *jog shuttle* and **SELECT** and **RESET** keys. For details on this operation, see sections 4.1 or 4.2.
- For a description of the operation using a USB keyboard or a USB mouse, see section 4.3.

Setting the Trigger Type

- Press **ENHANCED**. The ENHANCED menu appears.
- Press the **Type** soft key. The Type menu appears.
- Press the **Width** soft key.

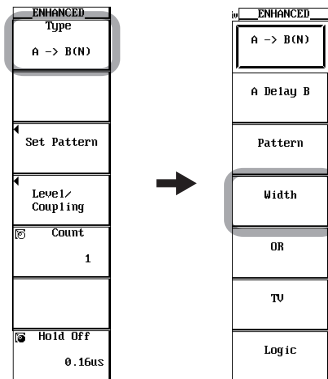

Setting the Width Type

- Press the **Width Type** soft key. The Width Type menu appears.
- Press the **Pulse<Time, Pulse>Time, T1<Pulse<T2, or Time Out** soft key.

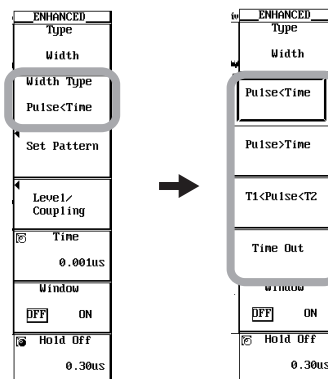

6.11 Setting the Width (Pulse<Time, Pulse>Time, T1<Pulse<T2, and Time Out) Trigger (ENHANCED)

Setting the Status of Each Channel

6. Press the **Set Pattern** soft key. The Set Pattern dialog box opens.
7. Use **jog shuttle & SELECT** to set the status of each channel to H, L, or X (IN, OUT, or X if Window is ON).
8. Use **jog shuttle & SELECT** to set Condition to True or False.

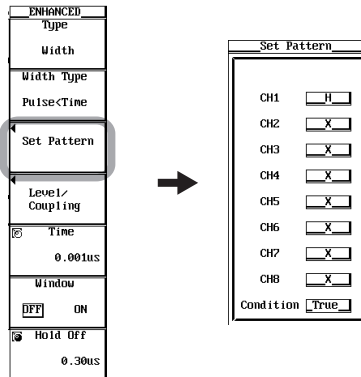

9. Press **ESC**. The Set Pattern dialog box closes.

Setting the Level, Hysteresis, Trigger Coupling, and HF Rejection

10. Press the **Level/Coupling** soft key. The Level/Coupling dialog box opens.
11. Like in the case of the A->B(N) trigger, set the level, hysteresis, trigger coupling, and HF rejection.
 - The setup procedure is common to the A->B(N) trigger. See page 6-16.
 - If Window is ON, set the window position and width, trigger coupling, and HF rejection. The setting is the same as the window trigger. See section 6.13.

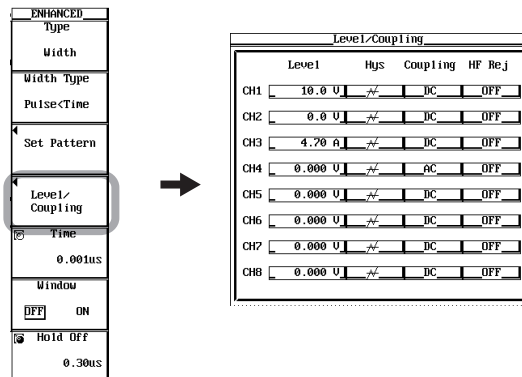

12. Press **ESC**. The Level/Coupling dialog box closes.

Note

The trigger level, hysteresis, trigger coupling, and HF rejection settings apply to both simple and enhanced triggers.

Setting the Determination Time

13. Press the **Time** soft key.
 - If Width Type is T1<Pulse<T2, press the Time1/Time2 soft key to set the jog shuttle control to Time1 or Time2.

6.11 Setting the Width (Pulse<Time, Pulse>Time, T1<Pulse<T2, and Time Out) Trigger (ENHANCED)

- Turn the **jog shuttle** to set the determination time.

Pressing RESET resets the determination time to 0.001 us (0.002 us for Time2).

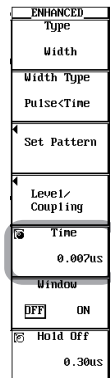

Setting the Window

- Press the **Window** soft key to select ON or OFF.
 - If set to OFF, a trigger is activated on the time over which the parallel pattern of the status (H, L, or X) of each channel is met or not met.
 - If set to ON, a trigger is activated on the time over which the parallel pattern of the window condition (IN, OUT, or X) of each channel is met or not met.

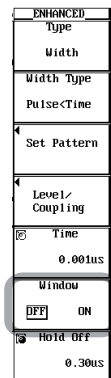

Setting the Hold Off

- Set the hold off time according to the procedures given in section 6.4.

6.11 Setting the Width (Pulse<Time, Pulse>Time, T1<Pulse<T2, and Time Out) Trigger (ENHANCED)

Explanation

This setting is for activating a trigger by determining whether the time over which the specified condition is met or not met is shorter or longer than the determination time set in advance.

Determination Type

You can select the type of determination.

Pulse<Time

A trigger is activated when the time over which the status pattern condition is met becomes shorter than the specified determination time.

Pulse>Time

A trigger is activated when the time over which the status pattern condition is met becomes longer than the specified determination time and the condition changes.

T1<Pulse<T2

A trigger is activated when the time over which the status pattern condition is met is between the two specified determination times.

Time Out

A trigger is activated when the time over which the status pattern condition is met becomes longer than the specified determination times.

Example

Pulse<Time, Condition: CH1 = H, CH2 = H, Other CHs: X, Condition = True, and Time = 400 ns

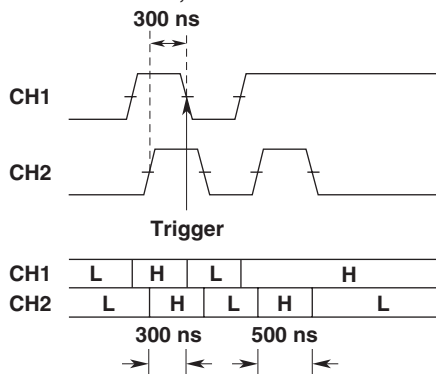

The point where the trigger occurs differs between Pulse > Time and Time Out as shown in the figure below.

Pulse>Time, CH1 = H, Other CHs: X, and Time = 400 ns

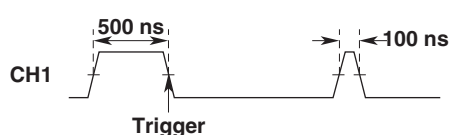

Time Out, CH1 = H, Other CHs: X, and Time = 400 ns

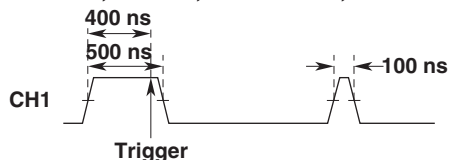

Status of Each Channel

- The status (H, L, and X) is the same as A->B(n) trigger when Window is OFF. See page 6-17.
- The status (IN, OUT, and X) is the same as the window trigger when Window is ON. For a description of the window trigger, see page 6-34.

Trigger Level

The selectable range is 8 divisions within the screen. The resolution is 0.01 divisions. For example, the resolution for 2 mV/div is 0.02 mV.

Hysteresis

Sets a width to the trigger level so that triggers are not activated by small changes in the trigger signal.

 Approximately 0.3 divisions* of hysteresis around the trigger level.

 Approximately 1 division* of hysteresis around the trigger level.

* The value above is an approximate value. It is not strictly warranted.

Trigger Coupling

You can select the trigger coupling.

AC Uses a signal that is obtained by removing the DC component from the trigger source signal.

DC Uses the trigger source signal as-is.

Turning ON/OFF the HF Rejection

Specify 15 kHz or 20 MHz if you wish to use a signal that is obtained by removing the high frequency components (frequency components greater than 15 kHz or 20 MHz) from the trigger source signal as the trigger source.

Determination Time

The selectable range is 1 ns to 1 s, and the resolution is 1 ns.

Relationship with the Window

When Window is turned ON, a trigger is also activated on the time over which the parallel pattern of the window condition (IN, OUT, or X) of each channel is met or not met. For details on the window, see section 6.13.

Hold Off

See section 6.4.

Note

The trigger may not operate correctly, if the interval between signals or the pulse width of the signal is less than 2 ns. The time accuracy of the pulse width under standard operating conditions after calibration is $\pm(0.5\% \text{ of setting} + 1 \text{ ns})$. However, the setting for T1<Pulse<T2 is the T2 value.

6.12 Setting the OR Trigger (ENHANCED)

<For a description of this function, refer to page 2-11.>

Procedure

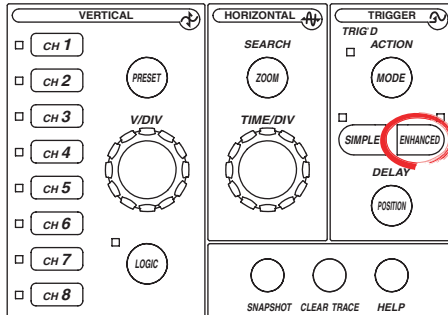

- To exit the menu during operation, press **ESC** located above the soft keys.
- In the procedural explanation below, the term *jog shuttle & SELECT* refers to the operation of selecting/setting items and entering values using the **jog shuttle** and **SELECT** and **RESET** keys. For details on this operation, see sections 4.1 or 4.2.
- For a description of the operation using a USB keyboard or a USB mouse, see section 4.3.

Setting the Trigger Type

1. Press **ENHANCED**. The ENHANCED menu appears.
2. Press the **Type** soft key. The Type menu appears.
3. Press the **OR** soft key.

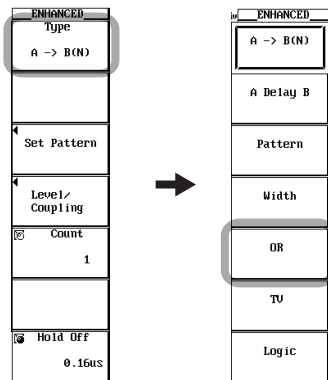

Setting the Slope of the Edge Trigger of Each Channel

4. Press the **Set Pattern** soft key. The Set Pattern dialog box opens.
5. Use **jog shuttle & SELECT** to set the slope of the edge trigger of each channel to \uparrow , \downarrow , or $-$ (IN, OUT, or $-$ if Window is ON).

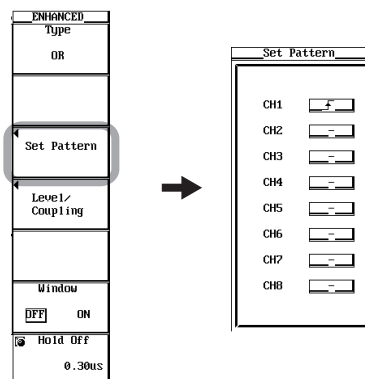

6. Press **ESC**. The Set Pattern dialog box closes.

Setting the Level, Hysteresis, Trigger Coupling, and HF Rejection

7. Press the **Level/Coupling** soft key. The Level/Coupling dialog box opens.
8. Like in the case of the A->B(N) trigger, set the level, hysteresis, trigger coupling, and HF rejection.
 - The setup procedure is common to the A->B(N) trigger. See page 6-16.
 - If Window is ON, set the window position and width, trigger coupling, and HF rejection. The setting is the same as the window trigger. See section 6.13.

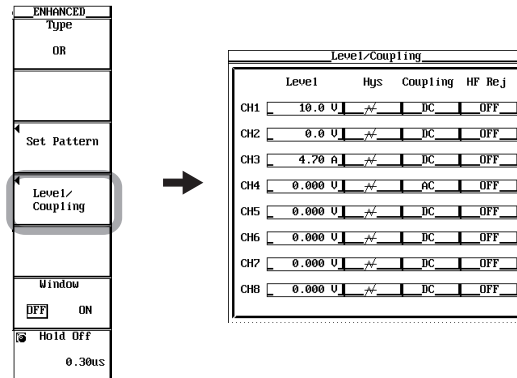

9. Press **ESC**. The Level/Coupling dialog box closes.

Note

The trigger level, hysteresis, trigger coupling, and HF rejection settings apply to both simple and enhanced triggers.

Setting the Window

10. Press the **Window** soft key to select ON or OFF.
 - If set to OFF, a trigger is activated on the OR logic of the edge of each channel.
 - If set to ON, a trigger is activated on the OR logic of the window condition of each channel.

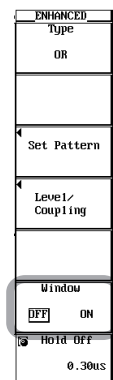

Setting the Hold Off

11. Set the hold off time according to the procedures given in section 6.4.



6.12 Setting the OR Trigger (ENHANCED)

Explanation

This setting is for activating a trigger on the OR logic of the edge trigger or the OR logic of the window trigger of each channel.

Slope of the Edge Trigger of Each Channel

You can select the slope of the edge trigger of each channel.



	Rising slope
	Falling slope
-	Don't Care

Trigger Level

The selectable range is 8 divisions within the screen. The resolution is 0.01 divisions. For example, the resolution for 2 mV/div is 0.02 mV.

Hysteresis

Sets a width to the trigger level so that triggers are not activated by small changes in the trigger signal.

	Approximately 0.3 divisions* of hysteresis around the trigger level.
	Approximately 1 division* of hysteresis around the trigger level.

* The value above is an approximate value. It is not strictly warranted.

Trigger Coupling

You can select the trigger coupling.

AC	Uses a signal that is obtained by removing the DC component from the trigger source signal.
DC	Uses the trigger source signal as-is.

Turning ON/OFF the HF Rejection

Specify 15 kHz or 20 MHz if you wish to use a signal that is obtained by removing the high frequency components (frequency components greater than 15 kHz or 20 MHz) from the trigger source signal as the trigger source.

Relationship with the Window

When Window is turned ON, a trigger is activated on the OR logic of the window conditions. For details on the window, see section 6.13.

Hold Off

See section 6.4.

6.13 Setting the Window Trigger (ENHANCED)

Procedure

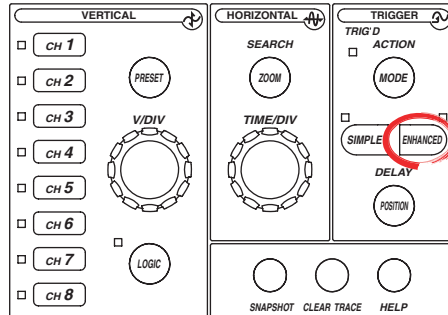

- To exit the menu during operation, press **ESC** located above the soft keys.
- In the procedural explanation below, the term *jog shuttle & SELECT* refers to the operation of selecting/setting items and entering values using the **jog shuttle** and **SELECT** and **RESET** keys. For details on this operation, see sections 4.1 or 4.2.
- For a description of the operation using a USB keyboard or a USB mouse, see section 4.3.

Setting the Trigger Type

1. Press **ENHANCED**. The ENHANCED menu appears.
2. Press the **Type** soft key. The Type menu appears.
3. Press the **Width** or the **OR** soft key.

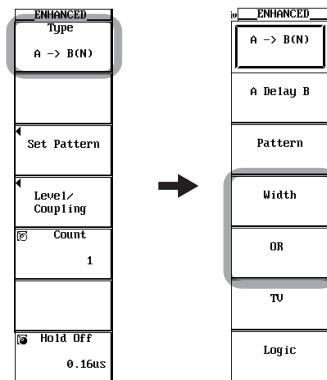

Setting the Window Trigger

4. Press the **Window** soft key to select ON.
Set the status and trigger condition of each channel according to the procedures given in section 6.11 or 6.12.

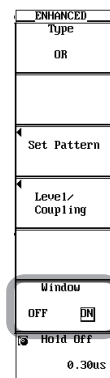

6.13 Setting the Window Trigger (ENHANCED)

Setting the Center Level and Window Width

5. Press the **Level/Coupling** soft key. The Level/Coupling dialog box opens.
6. Use **jog shuttle & SELECT** to set the window center level and the window width.

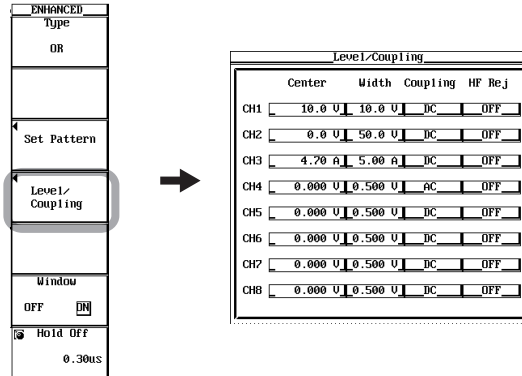

Setting the Trigger Coupling and HF Rejection

7. The setup procedure of the trigger coupling and HF rejection is common to the A->B(N) trigger. See page 6-16.
8. Press **ESC**. The Level/Coupling dialog box closes.

Explanation

This setting is for activating a trigger using a window trigger on the input signal of CH1 to CH8/4.

You can select up to CH4 and CH8 on the DL7440 and DL7480, respectively.

Trigger Condition

You can set a trigger condition for each trigger.

Window Trigger

IN The interval over which the trigger source is within a specified width is assumed to be the time over which the condition is met.

OUT The interval over which the trigger source is outside a specified width is assumed to be the time over which the condition is met.

OR Trigger

IN A trigger is activated when the trigger source enters a specified width.

OUT A trigger is activated when the trigger source exits from a specified width.

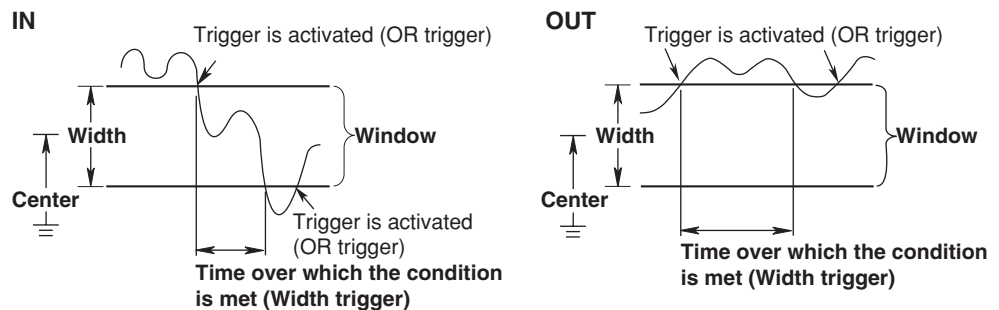

Window

A window is defined by its center level and width.

Selectable Range of Center

The selectable range is 8 divisions within the screen. The resolution is 0.01 divisions. For example, the resolution for 1 V/div is 0.01 V.

Selectable Range of Width

The selectable range is ± 0.5 to ± 4 divisions around the center level. The resolution is 0.01 divisions. For example, the resolution for 1 V/div is 0.01 V.

Note

The width level can be set above ± 4 divisions from the center of the screen. However, if either level exceeds the edge of the screen, the operation becomes unstable. Whenever possible, do not set the width level exceeding the display.

Trigger Coupling

You can select the trigger coupling.

AC Uses a signal that is obtained by removing the DC component from the trigger source signal.

DC Uses the trigger source signal as-is.

Turning ON/OFF the HF Rejection

Specify 15 kHz or 20 MHz if you wish to use a signal that is obtained by removing the high frequency components (frequency components greater than 15 kHz or 20 MHz) from the trigger source signal as the trigger source.

Relationship with the Width/OR Trigger

- The trigger types that the window trigger can use are Width and OR.
- To set the window trigger on a single channel, set the status of all channels except the channel to be used to – or X.

Hold Off

See section 6.4.

6.14 Setting the TV Trigger (ENHANCED)

Procedure

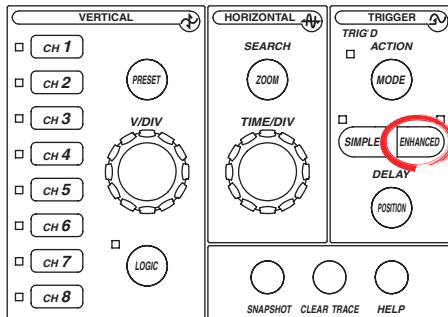

- To exit the menu during operation, press **ESC** located above the soft keys.
- For a description of the operation using a USB keyboard or a USB mouse, see section 4.3.

Applying a Video Signal

Connect the probe (cable) for applying the video signal to the CH1 input terminal.

Selecting the TV Trigger

1. Press **ENHANCED**. The ENHANCED menu appears.
2. Press the **Type** soft key. The Type menu appears.
3. Press the **TV** soft key.

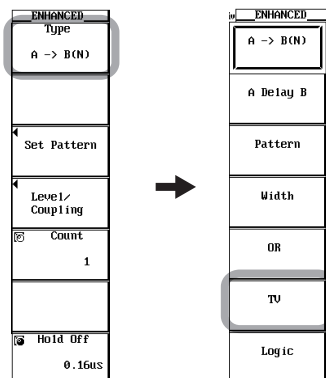

Selecting the Broadcasting Type of the Video Signal

4. Press the **TV Type** soft key. The TV Type menu appears.
5. Press the soft key corresponding to the broadcast type of the video signal.
The selections 480/60p, 1080/25p, 1080/24p, 1080/24sF, and 1080/60p are available on the page 2 menu.

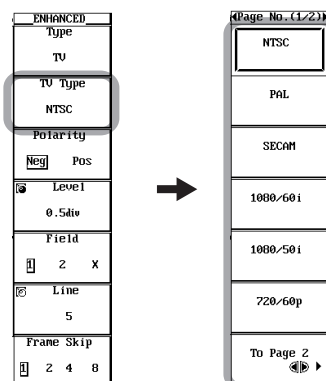

Selecting the Polarity

6. Press the **Polarity** soft key to select the polarity.

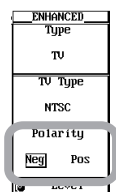
**Setting the Trigger Level**

7. Press the **Level** soft key.
8. Turn the **jog shuttle** to set the trigger level.
Pressing RESET sets the trigger level to 0.5 divisions or 1.0 division depending on the TV Type (broadcast type).

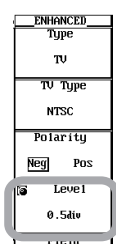
**Selecting the Field Number**

9. Press the **Field** soft key to select the field number.
This value cannot be specified when the TV Type is set to 720/60p, 480/60p, 1080/25p, 1080/24p, or 1080/60p.

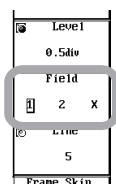
**Selecting the Line Number**

10. Press the **Line** soft key.
11. Turn the **jog shuttle** to select the line number.
Pressing RESET sets the minimum line setting to 8, 5, or 2 depending on the TV Type setting.

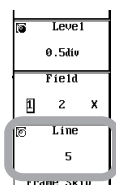

6.14 Setting the TV Trigger (ENHANCED)

Selecting Frame Skip

12. Press the **Frame Skip** soft key to select frame skip.

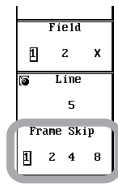

Explanation

This setting is for activating a trigger on a video signal applied to CH1.

Broadcast Types That TV Trigger Supports

You can select the broadcast type.

NTSC, PAL, SECAM, 1080/60i, 1080/50i, 720/60p, 480/60p, 1080/25p, 1080/24p, 1080/24sF, and 1080/60p

Field Number

You can select the field number to be detected.

- | | |
|---|--|
| 1 | Detect a field in which the start of the vertical sync pulse and the start of the line is at the same time. |
| 2 | Detect a field in which the start of the vertical sync pulse is delayed by 1/2 H (H is the horizontal scan interval) of the start of the line. |
| X | Detect both. |

Polarity

You can select Pos (positive) or Neg (negative).

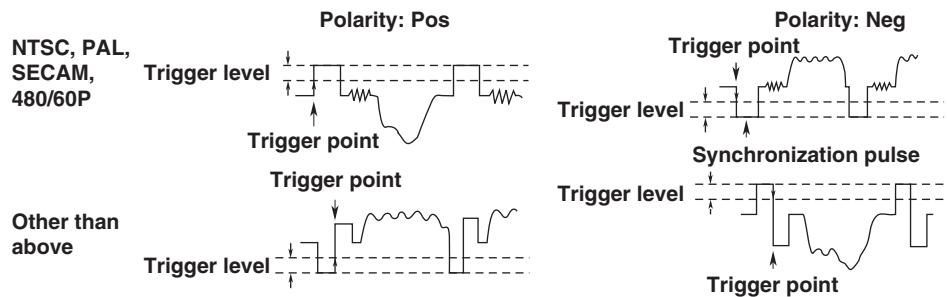

Trigger Level

Set the difference between the trigger level and the start value of the sync pulse in unit of divisions. The selectable range is 0.1 to 2.0 divisions within the screen. The resolution is 0.1 divisions. By default, the trigger level for NTSC, PAL, and SECOM is 0.5 divisions. For all other broadcasting types, the trigger level is 1.0 division.

Line Number

A trigger is activated at the start of the line of the selected number.

NTSC: 5 to 1054

The following line numbers are those when the field number is set to 1 (if the field number is set to 2, the numbers are assigned sequentially by setting 268 to 5).

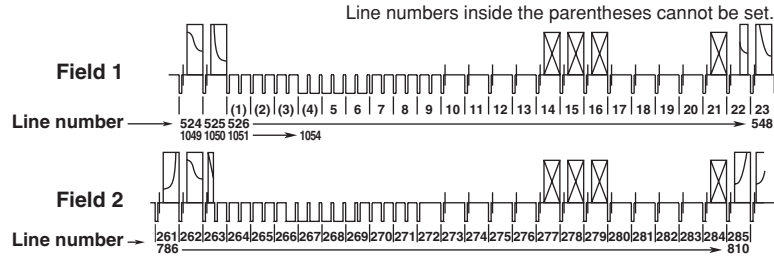

PAL or SECAM: 2 to 1251

The following line numbers are those when the field number is set to 1 (if the field number is set to 2, the numbers are assigned sequentially by setting 315 to 2).

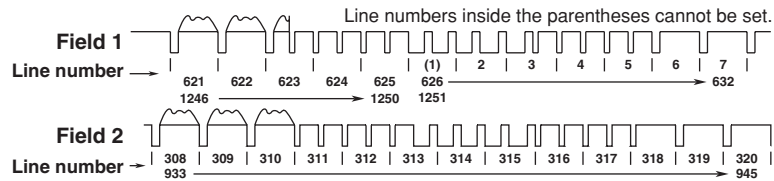

1080/60i, 1080/50i, or 1080/24sF: 2 to 2251

The following line numbers are those when the field number is set to 1 (if the field number is set to 2, the numbers are assigned sequentially by setting 565 to 2).

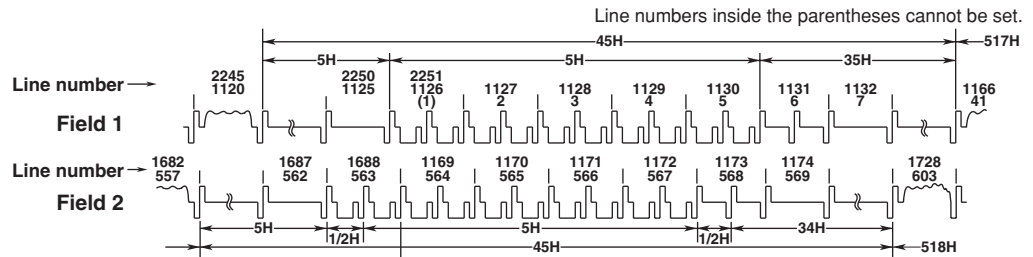

1080/25p, 1080/24p, or 1080/60p: 2 to 2251

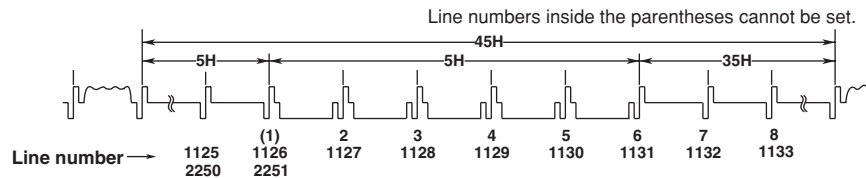

720/60p: 2 to 2251

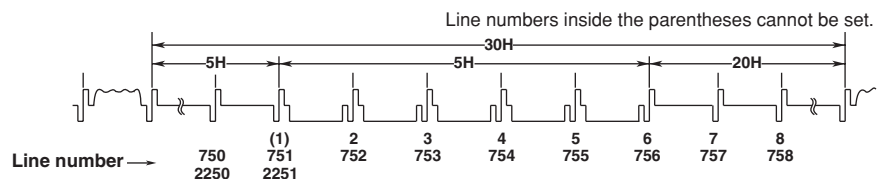

6.14 Setting the TV Trigger (ENHANCED)

480/60p: 8 to 2251

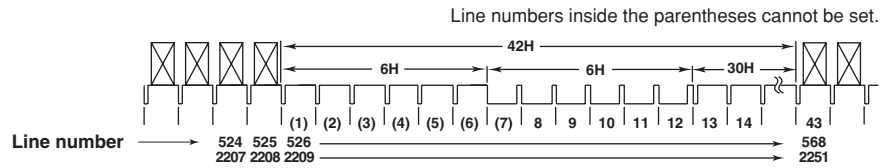

Frame Skip

This function is used to skip frames such as when the color burst is inverted every frame. You can select the number of frames at which this operation is repeated.

- | | |
|---|---|
| 1 | Activates a trigger at the specified field every time. |
| 2 | Skips 1 frame and activates a trigger at the specified field of the succeeding frame. This operation is repeated every 2 frames. |
| 4 | Skips 3 frames and activates a trigger at the specified field of the succeeding frame. This operation is repeated every 4 frames. |
| 8 | Skips 7 frames and activates a trigger at the specified field of the succeeding frame. This operation is repeated every 8 frames. |

Note

- Video signals can only be input to CH1. All other channels do not support video signals.
- Hold-off, trigger coupling, and HF rejection settings are ignored.

6.15 Setting the Logic Trigger (ENHANCED, Optional)

<For a description of this function, refer to page 2-12.>

Procedure

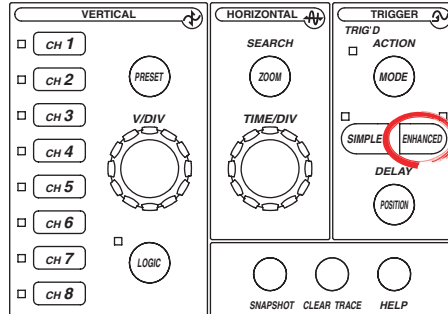

- To exit the menu during operation, press **ESC** located above the soft keys.
- In the procedural explanation below, the term *jog shuttle & SELECT* refers to the operation of selecting/setting items and entering values using the **jog shuttle** and **SELECT** and **RESET** keys. For details on this operation, see sections 4.1 or 4.2.
- For a description of the operation using a USB keyboard or a USB mouse, see section 4.3.

Setting the Trigger Type

1. Press **ENHANCED**. The ENHANCED menu appears.
2. Press the **Type** soft key. The Type menu appears.
3. Press the **Logic** soft key.

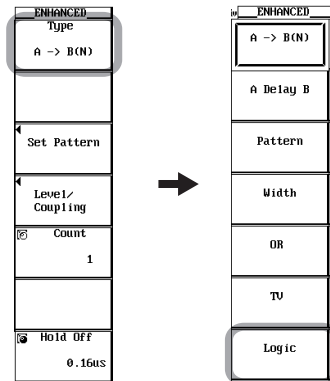

Setting the Status and Condition

4. Press the **Set Pattern** soft key. The Set Pattern dialog box opens.

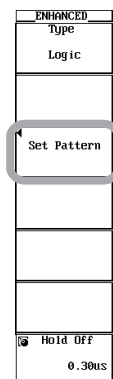

6.15 Setting the Logic Trigger (ENHANCED, Optional)

Activating a Trigger Only on the Status Pattern

5. Use **jog shuttle & SELECT** to set Clock Bit to None.
6. Use **jog shuttle & SELECT** to set the status of each bit to H, L, or X.
7. Use **jog shuttle & SELECT** to set trigger condition to Enter or Exit.
8. Press **ESC**. The Set Pattern dialog box closes.
Proceed to step 10.

Activating a Trigger in Synchronization with a Specified Bit Signal

5. Use **jog shuttle & SELECT** to set Clock Bit to the specified bit.
6. Use **jog shuttle & SELECT** to set the trigger slope of the bit set to be the clock channel to \uparrow or \downarrow .
7. Use **jog shuttle & SELECT** to set the status of the bits other than the bit set to be the clock bit to H, L, or X.
8. Use **jog shuttle & SELECT** to set trigger condition to True or False.
9. Press **ESC**. The Set Pattern dialog box closes.

Set Pattern	
Clock Bit	<input type="text" value="A0"/>
Pod A Pod B	
Bit0	<input type="text" value="↑ X X X"/>
Bit1	<input type="text" value="X X X X"/>
Bit2	<input type="text" value="X X X X"/>
Bit3	<input type="text" value="X X X X"/>
Bit4	<input type="text" value="X X X X"/>
Bit5	<input type="text" value="X X X X"/>
Bit6	<input type="text" value="X X X X"/>
Bit7	<input type="text" value="X X X X"/>
Condition	<input type="text" value="TRUE"/>

Setting the Hold Off

10. Set the hold off time according to the procedures given in section 6.4.

Explanation

This setting is for activating a trigger on the edge of a specified bit while the combination of the H, L, and Don't care of Pod A and B (16 bits) are met.

Logic Condition**Status of Each Pod**



H	Above the specified threshold level*
L	Below the specified threshold level*
X	Don't Care

* For a description of the threshold level, see section 5.10.

Clock Bit

You can select the synchronization signal for activating a trigger.

- Select None if the trigger is not to be activated in synchronization with the signal.
- When activating a trigger in synchronization with a signal, select 1 bit from bits A0 to A7 of Pod A and bits B0 to B7 of Pod B.
- You can select the trigger slope of the clock bit.

	Rising slope
	Falling slope

Selecting the Trigger Condition**Activating a Trigger Only on the Status Pattern**

You can select the condition for activating a trigger.

Enter	Activates a trigger when the specified combination (pattern) is met.
Exit	Activates a trigger when the specified pattern is no longer met.

Activating a Trigger in Synchronization with the Clock Bit

You can select the condition for activating a trigger.

True	A trigger is activated on the rising or falling edge of the clock bit while the status pattern is met.
False	A trigger is activated on the rising or falling edge of the clock bit while the status pattern is not met.

Note

If the setup time of the pattern against the clock signal is less 1 ns or the hold time is less than 1 ns when activating a trigger in synchronization with the clock bit signal, the trigger may not operate properly.

6.16 Setting the Action-on-Trigger

Procedure

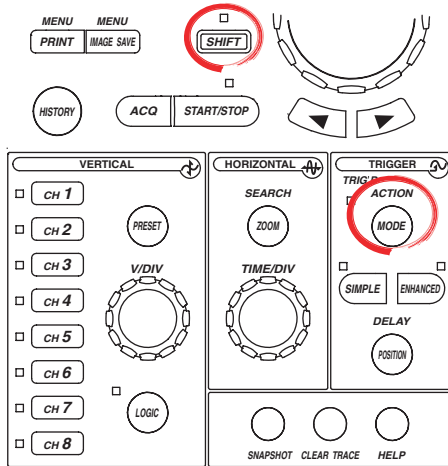

- To exit the menu during operation, press **ESC** located above the soft keys.
- For a description of the operation using a USB keyboard or a USB mouse, see section 4.3.

1. Press **SHIFT+MODE (ACTION)**. The ACTION menu appears.
2. Press the soft key corresponding to the action to be enabled and select ON.
If Send Mail is turned ON, use the jog shuttle to set the mail transmission count (MailCount).

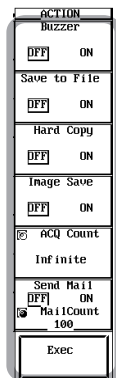

Setting the Action Count

3. Turn the **jog shuttle** to set the action count (ACQ Count).
Pressing RESET sets the count to Infinite.

Executing/Aborting Action-on-Trigger

4. Press the **Exec** soft key. The waveform acquisition starts and action-on-trigger is executed. The Exec soft key changes to Abort. To abort action-on-trigger, press the **Abort** soft key or **START/STOP**. The waveform acquisition stops and action-on-trigger is aborted.

Explanation

This setting is for performing a specified action each time the trigger is activated.

Action to Be Performed When the Trigger Condition Is Met

The specified action is performed whenever a trigger is activated.

Buzzer

Sounds a buzzer.

Save to File

Saves the data to the storage medium (floppy disk or Zip disk, PC card, Net Drive¹, SCSI device², or USB storage) specified in the FILE menu.

Hard Copy

Outputs the screen image data to the destination (built-in printer, USB, or Net Print¹) specified under "Print to" in the PRINT menu.

Image Save

Saves the screen image data to the storage medium (floppy disk, Zip disk, PC card, Net Drive¹, SCSI device², or USB storage) specified in the IMAGE menu.

Send Mail

Sends a mail message¹. Set the number of mail transmission in the range of 1 to 1000. For details, see section 13.5.

- 1 When the Ethernet interface option is installed
- 2 When the SCSI interface option is installed

Note

When the action-on-trigger is started, the specified action is performed when the trigger is activated in the normal mode regardless of the trigger mode setting.

Action Count

You can set the action count of the action-on-trigger.

1 to 65536	Repeats the action the specified number of counts.
Infinite	Repeats the action until waveform acquisition is stopped.

File Name When Save to File or Image Save Is Selected

The file name is automatically assigned by the auto naming function. For details, see section 12.8 or 12.12.

Trigger Mode

The trigger mode is set to Single.

Note

- Action-on-trigger cannot be used if the acquisition mode is Average.
- Settings cannot be changed while action-on-trigger is in progress.

6.17 Setting the Trigger Gate

Procedure

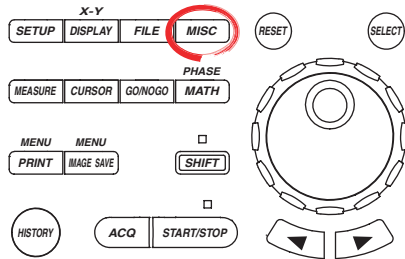

- To exit the menu during operation, press **ESC** located above the soft keys.
- For a description of the operation using a USB keyboard or a USB mouse, see section 4.3.

1. Press **MISC**. The MISC menu appears.
2. Press the **System Config** soft key. The System Config menu appears.
3. Press the **Trigger Gate** soft key to select OFF, Active High, or Active Low.

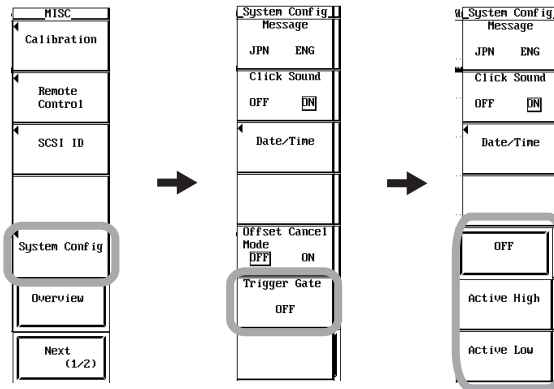

Explanation**Trigger Gate**

Set the timing when the specified trigger condition is activated.

OFF

When the trigger condition is met, the waveform is acquired.

Active High

When the external signal is low, the waveform is not acquired even when the trigger condition is met. When the trigger condition is met when the external signal is high, the waveform is acquired.

Active Low

When the external signal is high, the waveform is not acquired even when the trigger condition is met. When the trigger condition is met when the external signal is low, the waveform is acquired.

* When trigger gate is set to Active, A->B(N) trigger and A delay B trigger cannot be selected.

Level

High or Low is determined by referring to the external trigger level. See section 6.6. An external signal can be applied to the EXT TRIG IN/EXT CLOCK IN /TRIG GATE IN terminal on the rear panel.

Trigger Input Terminal

The external trigger input terminal (EXT TRIG IN) is also used as an external clock input terminal (EXT CLOCK IN). The terminal is used when you wish to activate the trigger using an external signal.

Item	Specifications
Connector type	BNC
Maximum input voltage	± 40 V (DC+ACpeak) or 28 Vrms when the frequency is 10 kHz or less
Frequency range	DC to 50 MHz
Input impedance	Approx. 1 M Ω , approx. 22 pF
Input range	± 2 V
Minimum input amplitude	0.1 V _{P-P}
Minimum pulse width	10 ns or more for high and low



EXT CLOCK IN
EXT TRIG IN
TRIG GATE IN
 ≈ 40 Vpk 1M Ω

Note

The determination level for the trigger gate input and the trigger level for the external trigger input are common.

**CAUTION**

Applying a voltage that exceeds the maximum allowable input voltage indicated above to the EXT CLOCK IN/EXT TRIG IN/TRIG GATE IN terminal can damage the input section.

7.1 Starting/Stopping Waveform Acquisition

Procedure

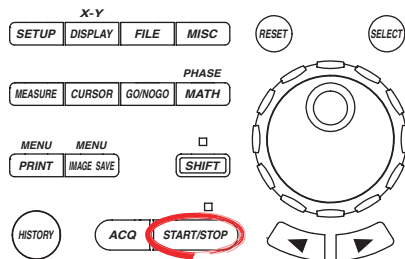

- To exit the menu during operation, press **ESC** located above the soft keys.
- For a description of the operation using a USB keyboard or a USB mouse, see section 4.3.

Press **START/STOP**.

Waveform acquisition is in progress when the indicator above and to the right of the key is illuminated. When waveform acquisition is stopped, the indicator is OFF and “Stopped” is displayed at the upper left corner of the screen.

Explanation

When waveform acquisition is started, waveform data is stored to the acquisition memory each time a trigger is activated, and the displayed waveform is updated. The acquisition memory is divided by the specified record length, and the maximum number of waveforms that can be acquired is retained. The past waveforms that have been retained can be recalled and displayed using the history memory function when waveform acquisition is stopped. For the procedure of recalling waveforms using the history memory function, see section 10.1.

Operation When the Acquisition Mode Is Set to Averaging Mode

- Averaging is stopped when waveform acquisition is stopped.
- Averaging starts again when waveform acquisition is restarted.

START/STOP Operation during Accumulation

Accumulation is aborted when acquisition is stopped. When acquisition is started, the accumulated waveforms up to that point are cleared, and new accumulation is started.

Events that Disable the START/STOP key

- When remote mode is engaged using the communication interface.
- When printing, during auto setup, and while the storage medium is being accessed.

Note

- Pressing the FILE key or HISTORY key while acquiring waveforms stops waveform acquisition.
- If you start waveform acquisition after changing the waveform acquisition conditions, the data that had been stored in the acquisition memory up to that point is cleared.
- A snapshot function that keeps the current displayed waveform on the screen is also available. You can update the display without stopping waveform acquisition (see section 8.6).

7.2 Setting the Record Length

<For a description of this function, refer to page 2-15.>

Procedure

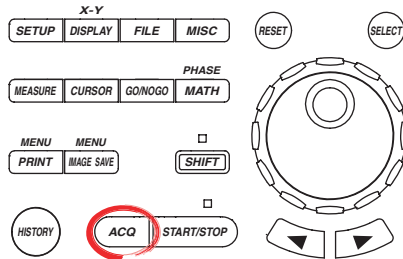

- To exit the menu during operation, press **ESC** located above the soft keys.
- For a description of the operation using a USB keyboard or a USB mouse, see section 4.3.

1. Press **ACQ**. The ACQ menu appears.
2. Press the **Record Length** soft key.
3. Turn the **jog shuttle** to select the record length from 1k to 8M (2M).
 - If interleave mode is ON, you can select the record length in the range of 1k to 16M (4M).
 - The selectable maximum record length varies depending on the model.

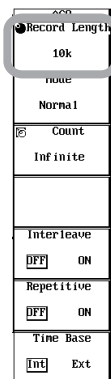

Explanation

You can set the record length (the number of data points) to be stored to the acquisition memory.

The selectable maximum record length varies depending on the model.

16 MW memory model (701460 and 701480)
1k, 10k, 50k, 100k, 250k, 500k, 1M, 2M, 4M, 8M (, or 16M)

4 MW memory model (701450 and 701470)
1k, 10k, 50k, 100k, 250k, 500k, 1M, 2M (, or 4M)

* The value inside the parentheses is selectable only when interleave mode is ON (see the next section).

Note

- The sample rate and display record length vary depending on the T/div setting. For details, see appendix 1.
- The maximum record length for box average is half the record length of each model indicated above.
- Waveform computation cannot be performed at the following record lengths.
When interleave mode is OFF: 8 MW
When interleave mode is ON: 16 MW

7.3 Using Interleave Mode

Procedure

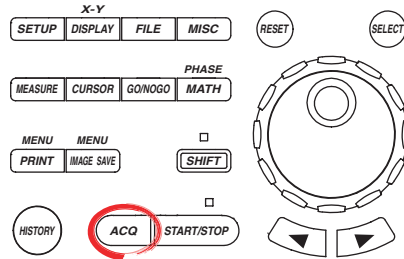

- To exit the menu during operation, press **ESC** located above the soft keys.
- For a description of the operation using a USB keyboard or a USB mouse, see section 4.3.

1. Press **ACQ**. The ACQ menu appears.
2. Press the **Interleave** soft key to select ON or OFF.

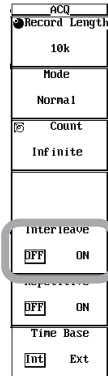

Explanation

When interleave mode is turned ON, the number of channels that can be used is limited, but history memory, sequential store count, and record length can be set to twice the normal values. In addition, in realtime sampling mode, sampling becomes possible at a rate of up to 2 GS/s. The channels that cannot be used when interleave mode is turned ON are CH2, CH4, CH6, and CH8 (CH2 and CH4 on the DL7440). If the optional logic input is available, POD B cannot be used. For a description of the limitations of the record length, sample rate, and other items when interleave mode is turned ON, see appendix 1.

7.4 Turning ON/OFF Repetitive Sampling Mode

<For a description of this function, refer to page 2-15.>

Procedure

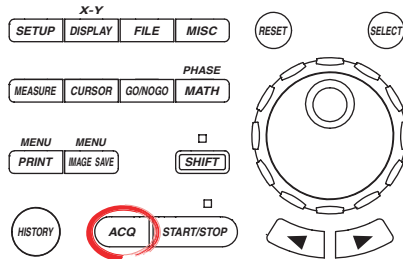

- To exit the menu during operation, press **ESC** located above the soft keys.
- For a description of the operation using a USB keyboard or a USB mouse, see section 4.3.

1. Press **ACQ**. The ACQ menu appears.
2. Press the **Repetitive** soft key to select ON or OFF.

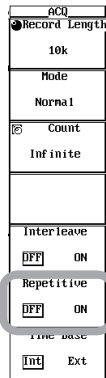

Explanation

You can turn repetitive sampling ON or OFF. For a description of the record length and sample rate when in repetitive sampling mode, see appendix 1.

Possible T/div Settings for Performing Repetitive Sampling

If repetitive sampling mode is turned ON and the time axis is set according to the table below, repetitive sampling is performed. The possible T/div settings for performing repetitive sampling vary depending on the record length and model.

Record Length	T/div	
1 kW	1 ns/div to 50 ns/div	(1 ns/div to 20 ns/div)
10 kW	1 ns/div to 500 ns/div	(1 ns/div to 200 ns/div)
50 kW	1 ns/div to 2 μs/div	(1 ns/div to 1 μs/div)
100 kW	1 ns/div to 5 μs/div	(1 ns/div to 2 μs/div)
250 kW	1 ns/div to 10 μs/div	(1 ns/div to 5 μs/div)
500 kW	1 ns/div to 20 μs/div	(1 ns/div to 10 μs/div)
1 MW	1 ns/div to 50 μs/div	(1 ns/div to 20 μs/div)
2 MW	1 ns/div to 100 μs/div	(1 ns/div to 50 μs/div)
4 MW	1 ns/div to 200 μs/div	(1 ns/div to 100 μs/div)
8 MW	1 ns/div to 500 μs/div	(1 ns/div to 200 μs/div)
16 MW	—	(1 ns/div to 5 ns/div) ²

- 1 The record length is up to 2 MW when interleave mode is OFF on the 4 MW memory model (701450 and 701470). The values inside the parentheses are the selectable ranges when interleave mode is ON.
- 2 The repetitive sampling mode setting remains OFF, but repetitive sampling is performed.

Note

- When the record length is 16 MW, you cannot switch repetitive sampling mode ON/OFF. The menu indicates OFF.
 - When repetitive sampling mode is turned ON, the sample rate is set greater than or equal to 2 GS/s (greater than or equal to 5 GS/s when interleave mode is ON) for certain T/div settings.
 - When repetitive sampling is turned OFF, sampling is performed at a rate of up to 1 GS/s (2 GS/s when interleave mode is ON). When the number of displayed data points is less than 500, data is interpolated and displayed. However, even when repetitive sampling is turned OFF, repetitive sampling may be performed depending on the time axis setting.
 - When repetitive sampling is in progress, waveform acquisition using the Single(N) trigger mode is not possible.
-

7.5 Setting the Acquisition Mode

<For a description of this function, refer to page 2-15.>

Procedure

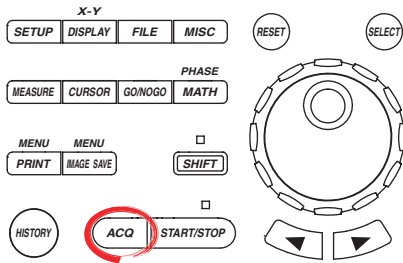

- To exit the menu during operation, press **ESC** located above the soft keys.
- For a description of the operation using a USB keyboard or a USB mouse, see section 4.3.

Setting the Acquisition Mode

1. Press **ACQ**. The ACQ menu appears.
2. Press the **Mode** soft key. The Mode menu appears.
3. Press a soft key to select the acquisition mode.

You may not be able to select some modes depending on the trigger mode setting.

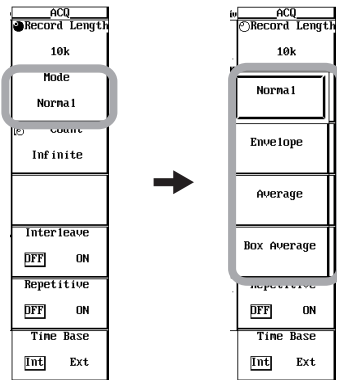

Setting the Acquisition Count

4. Press the **Count** soft key.
 - You cannot set the acquisition count when the trigger mode is Single or Single (N).
5. Turn the **jog shuttle** to set the acquisition count.
 - Pressing **RESET** resets the count to Infinite.
 - If the acquisition mode is Average and you set Count to Infinite, proceed to step 6.

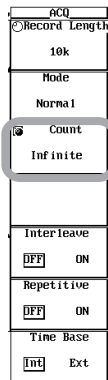

Setting the Attenuation Constant (When the Acquisition Mode Is Average and Count Is Infinite)

6. Press the **Weight** soft key.
7. Turn the **jog shuttle** to set the attenuation constant.



Explanation

You can select the acquisition mode from the following. The default setting is normal mode.

Normal Mode

Sampled data is stored in the acquisition memory without special processing.

Envelope Mode

Regardless of the interleave mode setting (ON or OFF), the maximum and minimum values are determined every acquisition interval from the data sampled at 1 GS/s or 800 MS/s. The maximum and minimum values are stored to the acquisition memory and an envelope waveform is displayed.

Note

This mode can be specified when the time axis would be 500 MS/s or less in normal mode regardless of the interleave mode setting (ON or OFF). For all other cases, the mode is set to normal mode even when envelope mode is specified.

Averaging Mode

Sampled data is averaged and stored to the acquisition memory. The averaging method varies depending on the acquisition count setting. If the acquisition count is set to Infinite, exponential averaging is performed and you must set the attenuation constant (Weight). If the acquisition count is set to a value in the range of 2 to 65536, simple averaging is performed. The specified value is the average count.

Exponential Average

Cannot be specified when the trigger mode is Single or Single (N).

Simple Average

Switches to exponential averaging when in repetitive sampling mode. The maximum record length is 4 MW (8 MW when interleave mode is ON).

Exponential average (when set to Infinite)

$$A_n = \frac{1}{N} \{(N-1)A_{n-1} + X_n\}$$

A_n : nth averaged value

X_n : nth measured value

N : Attenuation (2 to 256, 2^n steps)

Simple average (when set to 1 to 65536)

$$A_n = \frac{\sum_{n=1}^N X_n}{N}$$

X_n : nth measured value

N : Average count

(acquisition count, 2^n steps)

For the relationship between the time axis setting and roll mode or repetitive sampling mode, see appendix 1.

7.5 Setting the Acquisition Mode

Box Average

At sample rates that allow box averaging, data is normally sampled at 1 GS/s or 800 MS/s regardless of the interleave mode setting (ON or OFF), and the sampled data is decimated according to the T/div setting and stored to the acquisition memory. The internal sample rate is the same as the envelope mode. For details, see appendix 1. When you use the box averaging function, the operation is different. Moving average is computed on a given number of data points, and the result is sampled and stored to the acquisition memory.

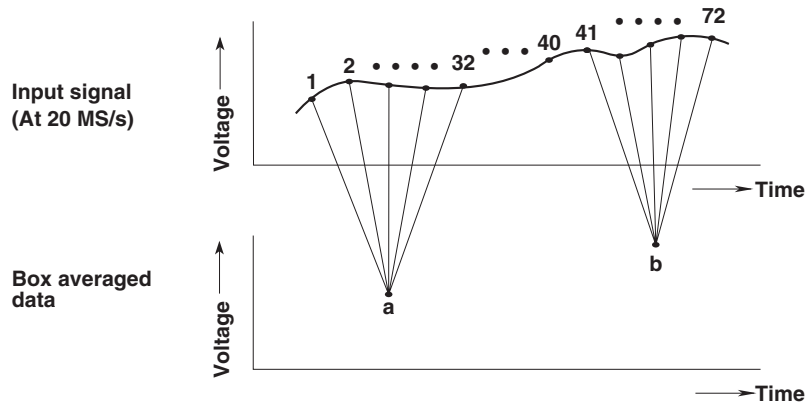

Sample Rate and Number of Moving Average Points

Sample Rate	Number of Moving Average Points
500 MS/s	2 points every 2 points of 1 GS/s
200 MS/s	4 points every 4 points of 800 MS/s
100 MS/s	8 points every 8 points of 800 MS/s
50 MS/s	16 points every 16 points of 800 MS/s
20 MS/s	32 points every 40 points of 800 MS/s
10 MS/s	64 points every 80 points of 800 MS/s
5 MS/s	128 points every 160 points of 800 MS/s
2 MS/s	256 points every 400 points of 800 MS/s
1 MS/s	256 points every 800 points of 800 MS/s
500 kS/s or less	256 points every 1600* points of 800 MS/s

* The interval at which data is resampled varies depending on the sample rate. However, the maximum number of data points that is box averaged is 256.

Possible Record Lengths

16 MW memory model (701460 and 701480)
4 MW or less (8 MW or less when in interleave mode)
4 MW memory model (701450 and 701470)
1 MW or less (2 MW or less when in interleave mode)

Possible Sample Rates

Sample rates can be set up to 500 MS/s regardless of the interleave mode setting (ON or OFF). If the sample rate exceeds 500 MS/s regardless of the interleave mode setting (ON or OFF), the acquisition mode is set to normal mode even when box average is specified.

Acquisition Count

You can set the acquisition count. If you set the value to Infinite, acquisition will continue until you press the START/STOP key. The default setting is Infinite. You cannot change the acquisition count while measurement is in progress. Stop the measurement first.

Normal, Envelope, and Box Average
2 to 65536 (1 step), Infinite

Averaging
2 to 65536 (2ⁿ steps), Infinite

Note

- Averaging is effective only for repetitive waveforms.
 - Correct averaging is not possible if the waveform has imperfect triggering (incomplete synchronization), and the displayed waveform will be distorted. When working with this type of signal, set the trigger mode to Normal, so that the waveform display is updated only when the trigger is activated (see section 6.1).
 - Roll mode display is disabled when averaging is used.
 - If you stop waveform acquisition by pressing the START/STOP key, the averaging process also stops. Averaging restarts from the beginning when acquisition resumes.
 - If you are using simple averaging, the DL7400 terminates acquisition automatically when it completes the specified number of acquisitions (acquisition count).
 - Averaging is not performed on the logic input (optional) even when the acquisition mode is set to average or box average.
 - When in repetitive sampling mode, only exponential averaging is executed.
-

7.6 Performing Sequential Store (SINGLE(N) Mode)

<For a description of this function, refer to page 2-17.>

Procedure

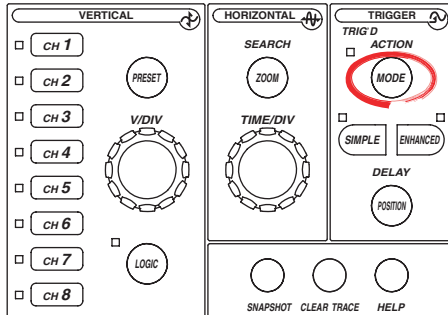

- To exit the menu during operation, press **ESC** located above the soft keys.
- For a description of the operation using a USB keyboard or a USB mouse, see section 4.3.

1. Press **MODE**. The MODE menu appears.
2. Press the **Single(N)** soft key to set the trigger mode to Single(N).
3. Use the **jog shuttle** to set Single(N) Count.

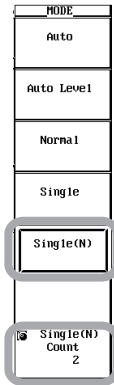

Explanation

This setting is for using the sequential store (SINGLE (N) mode) function. The sequential store function sequentially acquires waveforms the specified number of times when the trigger conditions are met and displays the waveforms after acquisition stops. In sequential store (SINGLE (N) mode), the interval for acquiring waveforms is minimized by not performing other processes such as waveform display until the acquisition of the specified number of waveforms is complete.

Acquisition Count

You can set the acquisition count. The acquisition count that can be specified varies depending on the specified record length as follows.

Specified Record Length	Count When in Normal Mode		Count When in Box Average Mode	
	16 MW memory model	4 MW memory model	16 MW memory model	4 MW memory model
1 kW	1 to 2048 (4096)	1 to 1024 (2048)	1 to 2048 (4096)	1 to 512 (1024)
10 kW	1 to 256 (512)	1 to 128 (256)	1 to 256 (512)	1 to 64 (128)
50 kW	1 to 64 (128)	1 to 32 (64)	1 to 64 (128)	1 to 16 (32)
100 kW	1 to 32 (64)	1 to 16 (32)	1 to 32 (64)	1 to 8 (16)
250 kW	1 to 16 (32)	1 to 8 (16)	1 to 16 (32)	1 to 4 (8)
500 kW	1 to 8 (16)	1 to 4 (8)	1 to 8 (16)	1 to 2 (4)
1 MW	1 to 4 (8)	1 to 2 (4)	1 to 4 (8)	1 (2)
2 MW	1 to 2 (4)	1 (2)	1 to 2 (4)	-(1)
4 MW	1 (2)	-(1)	1 (2)	-
8 MW	1 (1)	-	-(1)	-
16 MW	-(1)	-	-	-

* The value inside the parentheses is selectable only when interleave mode is ON.

Displaying Waveforms

You can recall waveforms from memory in the same fashion as with the history memory function. For details, see section 10.1.

Note

- Sequential store is not possible when in repetitive sampling mode or roll mode.
- If you stop waveform acquisition by pressing the START/STOP key, the sequential store operation also stops. If restarted, the acquisition count is reset, and waveform is acquired from the first waveform.

8.1 Setting the Display Format

Procedure

Setting the Display Format of Normal Waveforms

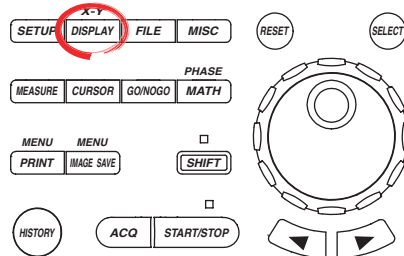

- To exit the menu during operation, press **ESC** located above the soft keys.
- In the procedural explanation below, the term *jog shuttle & SELECT* refers to the operation of selecting/setting items and entering values using the **jog shuttle** and **SELECT** and **RESET** keys. For details on this operation, see sections 4.1 or 4.2.
- For a description of the operation using a USB keyboard or a USB mouse, see section 4.3.

Selecting the Display Format

1. Press **DISPLAY**. The DISPLAY menu appears.
2. Press the **Format** soft key. The Format menu appears.
3. Press one of the **Single to Octal** keys to select the display format.
Octal can be used on the DL7480.

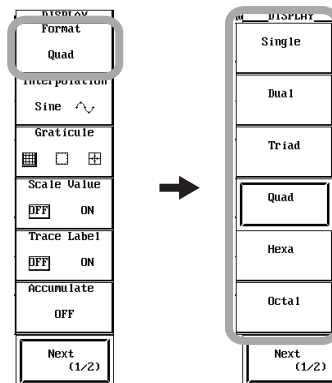

Setting the Waveform Mapping

4. Press the **Next (1/2)** soft key. The page 2 menu appears.
5. Press the **Mapping** soft key.
6. Press the **Auto**, **Fixed**, or **User** soft key to select the waveform mapping method.
 - If you select Auto or Fixed, you are done.
 - If you select User, proceed to step 7.
7. Press the **Set Mapping** soft key. The Set Mapping dialog box appears.
8. Use **jog shuttle & SELECT** to set the mapping number of each channel.

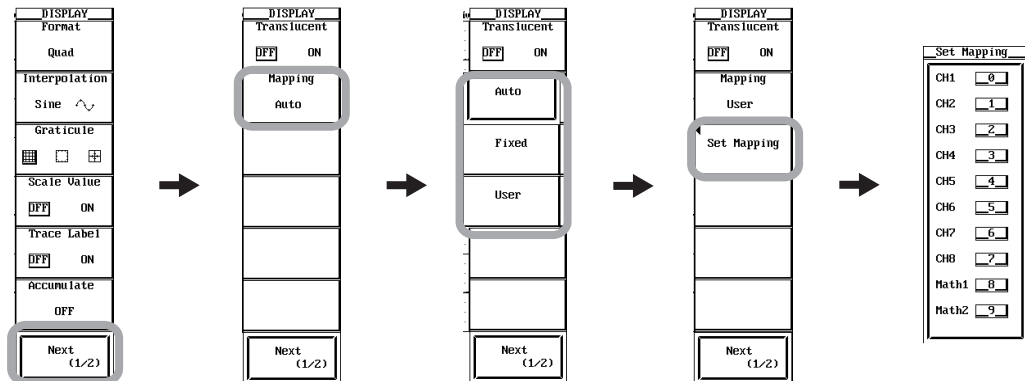

8.1 Setting the Display Format

Setting the Display Format of Logic Waveforms

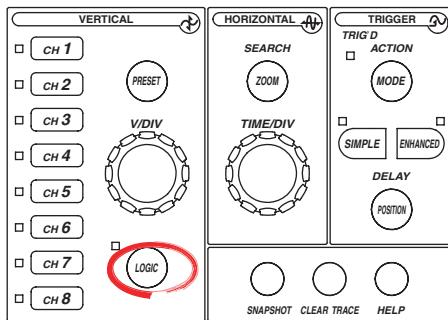

- To exit the menu during operation, press **ESC** located above the soft keys.
- For a description of the operation using a USB keyboard or a USB mouse, see section 4.3.

1. Press **LOGIC**. The LOGIC menu appears.
2. Press the **Mode** soft key to select **ON**. The Format menu appears.
3. Press the **Format** soft key to select **Both** or **Only**.
 - If you select Both, normal waveforms and logic waveforms are displayed simultaneously in divided windows (top and bottom).
 - If you select Only, only the logic waveforms are displayed over the entire screen.

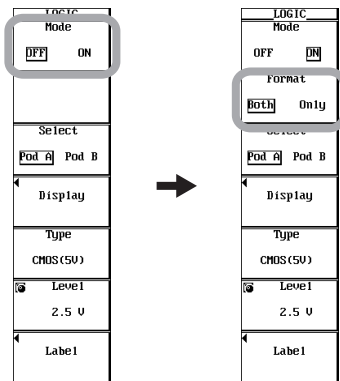

Note

For a description of the other menus displayed on the LOGIC menu, see section 5.10.

Explanation

You can select the number of windows into which the normal analog waveform (normal waveform) display window is divided. The position of the waveform of each channel varies depending on the display format. You can also select the display format when displaying logic waveforms and normal waveforms.

Normal Waveform Display Format (Number of Divided Windows)

Single	1 window
Dual	2 windows
Triad	3 windows
Quad	4 windows
Hexa	6 windows
Octal	8 windows (DL7480 only)

- The number of displayed points in the vertical direction of one divided window varies depending on the number of windows as follows. The vertical resolution of the waveform data stored to the acquisition memory remains unchanged even if the number of displayed points changes.

Single	384 points (240 points)
Dual	192 points (120 points)
Triad	128 points (80 points)
Quad	96 points (60 points)
Hexa	64 points (40 points)
Octal	48 points (30 points) (DL7480 only)

The values inside the parentheses are those when the logic input is also displayed.

Normal Waveform Mapping**Auto**

The waveforms whose display is turned ON are assigned in the order of CH1, CH2, ..., CH8/4, Math1, and Math2 to the divided windows from the top window. Channels whose display is turned OFF are excluded.

Fixed

Regardless of whether the display is turned ON/OFF, the waveforms are assigned in the order of CH1, CH2, ..., CH8/4, Math1, and Math2 to the divided windows from the top window.

User

The waveforms can be assigned arbitrarily to the divided windows regardless of whether the display is turned ON/OFF. You can select the display position from 0 to 7. The waveforms are assigned in order starting from number 0 from the top divided window.

Display Example When Display Format Is Dual

Auto
(CH3 and CH5 to CH8 displays are OFF)

CH1, CH4
CH2

Fixed
(CH3 and CH5 to CH8 displays are OFF)

CH1
CH2, CH4

User

Display position number 0, 2, 4, 6
1, 3, 5, 7

Display Format of Logic Waveforms

You can select the format for displaying logic waveforms.

Both

Normal waveforms and logic waveforms are displayed simultaneously in divided windows (top and bottom).

Only

Only logic waveforms are displayed over the entire screen.

- * A display example when Both is selected is given on page 1-7.

8.2 Performing Display Interpolation

<For a description of this function, refer to page 2-18.>

Procedure

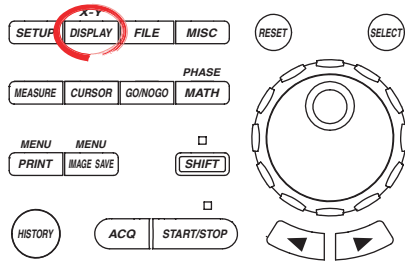

- To exit the menu during operation, press **ESC** located above the soft keys.
- For a description of the operation using a USB keyboard or a USB mouse, see section 4.3.

Setting the Interpolation Method

1. Press **DISPLAY**. The DISPLAY menu appears.
2. Press the **Interpolation** soft key. The Interpolation menu appears.
3. Press the **OFF**, **Sine**, **Line**, or **Pulse** soft key to select the interpolation method.

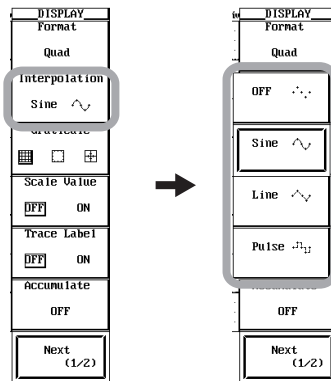

Explanation

Interpolation Method

Any area along the time axis having less than 500 points in 10 divisions (less than 250 points in the Z1 and Z2 window when displaying Main&Z1&Z2) is recognized as an interpolation area. If you leave interpolation off, these points will appear as discrete dots (so that the display will show gaps between dots or vertical lines). If you set interpolation on, however, the DL7400 will connect the points. The following methods are available.

Sine()

Interpolates between two points using the sin x/x function.

Line()

Linearly interpolates between two points.

Pulse()

Interpolates between the two points by drawing a horizontal line to the time axis position of the next data point, then connecting the end of the horizontal line to the next data point with a vertical line

OFF()

No interpolation is performed.

When the Area Is Not an Interpolation Area

As shown in the figure below, if the interpolation method is set to Sine, Line, or Pulse, the instrument draws lines between points that are aligned vertically.

When the interpolation method is OFF

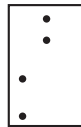

When the interpolation method is Sine, Line, or Pulse



When the Area Is an Interpolation Area

When the interpolation method is OFF

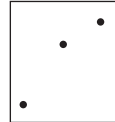

When the interpolation method is Sine



When the interpolation method is Line



When the interpolation method is Pulse

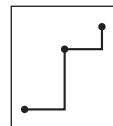

8.3 Accumulating Waveforms

Procedure

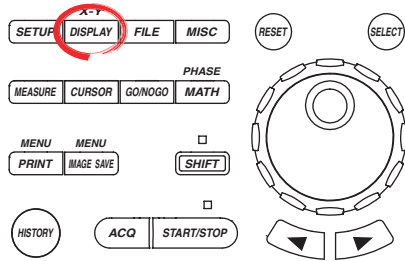

- To exit the menu during operation, press **ESC** located above the soft keys.
- For a description of the operation using a USB keyboard or a USB mouse, see section 4.3.

Setting the Accumulate Mode

1. Press **DISPLAY**. The DISPLAY menu appears.
2. Press the **Accumulate** soft key. The Accumulate menu appears.
3. Press the **OFF**, **Persist**, or **Color** soft key to select the accumulate mode.

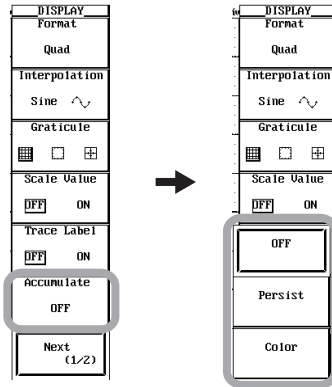

Setting the Accumulation Time (When Persist Mode Is Selected)

4. Turn the **jog shuttle** to set the accumulation time.

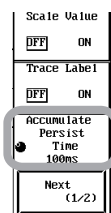

Setting the Grade Width (When Color Mode Is Selected)

4. Turn the **jog shuttle** to set the grade width.

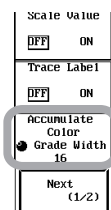

Explanation

Normally, the display is updated every time a trigger is activated making it difficult to capture transient conditions such as sudden distortion of waveforms. By using the accumulate function, the waveform display of the acquired data remains on the screen for the specified time.

Accumulate Mode

Persist (persistent mode)

Accumulates waveforms using each channel color. The intensity is gradually reduced, and the waveform disappears after the specified accumulation time.

Color (color grade mode)

Accumulates waveforms using eight colors indicating data frequency information.

Accumulation Time

In persistent mode (Persist), you can select the time until the waveform disappears. If you select Infinite, the waveform does not disappear. The default setting is 100 ms.

100ms, 200ms, 500ms, 1s, 2s, 5s, 10s, 20s, 50s, or Infinite

Grade Width

When in color grade mode (Color), the frequency of the data is distinguished using 8 colors as shown in the following figure. You can set the boundary value (width) of the colors. The default setting is 16. The accumulation time when in color grade mode is infinite.

2 to 2048 (2ⁿ steps)

High frequency ↑	When the grade width = 4		When the grade width = 128	
	Color	Count Range	Color	Count Range
	Red	28+	Red	896+
	Pink	24 to 27	Pink	768 to 895
	Orange	20 to 23	Orange	640 to 767
	Yellow	16 to 19	Yellow	512 to 639
	White	12 to 15	White	384 to 511
	Cyan	8 to 11	Cyan	256 to 383
	Green	4 to 7	Green	128 to 255
	Blue	1 to 3	Blue	1 to 127
	Black	0	Black	0

For example, the point (dot) that is drawn 100 times on the screen as a result of accumulation is red when the grade width is 4 and blue when the grade width is 128.

Clearing Accumulated Waveforms

You can clear accumulated waveforms by pressing the CLEAR TRACE key.

Note

- Automated measurement of waveform parameters and GO/NO-GO determination are executed on the waveform acquired last.
- If all the history waveforms are displayed when accumulation is in progress, all the history waveforms are displayed using the specified accumulate mode. However, the waveform display is slowed down.
- The built-in printer (optional) prints accumulated waveforms using two tones.
- On an external printer, only the newest waveform is printed.
- If waveform acquisition is stopped by pressing the START/STOP key, accumulation is aborted. When waveform acquisition is started, the accumulated waveforms up to that point are cleared, and new accumulation is started.

8.4 Zooming the Waveform

<For a description of this function, refer to page 2-19.>

Procedure

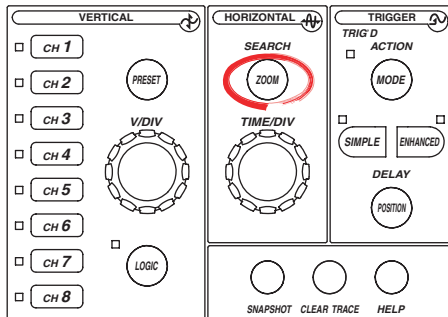

- To exit the menu during operation, press **ESC** located above the soft keys.
- In the procedural explanation below, the term *jog shuttle & SELECT* refers to the operation of selecting/setting items and entering values using the **jog shuttle** and **SELECT** and **RESET** keys. For details on this operation, see sections 4.1 or 4.2.
- For a description of the operation using a USB keyboard or a USB mouse, see section 4.3.

Selecting the Display Mode

1. Press **ZOOM**. The ZOOM menu appears.
2. Press the **Mode** soft key. The Mode menu appears.
3. Press any soft key from **Main** to **Main&Z1&Z2** to select the display mode.
If you select Main, you are done.

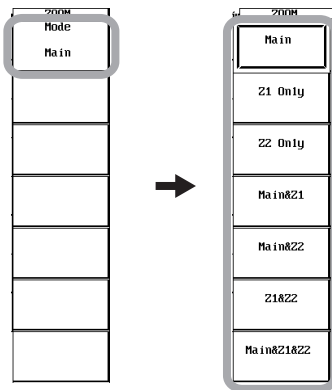

Selecting the Display Format

4. Press the **Format** soft key. The Format menu appears.
If you set Mode to Main, the Format soft key does not appear.
5. Press any soft key from **Main** to **Octal** to select the display format.
Octal can be used on the DL7480.

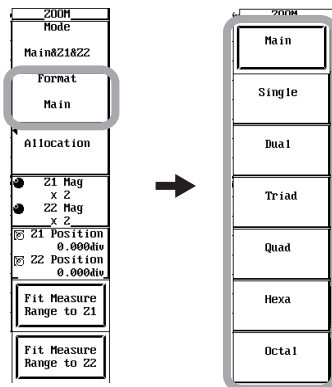

Setting the Waveform to Be Zoomed

- 6. Press the **Allocation** soft key. The Allocation dialog box appears.
- 7. Use **jog shuttle & SELECT** to select the waveform to be zoomed.
 - If All ON is executed using jog shuttle & SELECT, all the waveforms currently displayed are selected.
 - If All OFF is executed using jog shuttle & SELECT, all the waveforms are deselected.

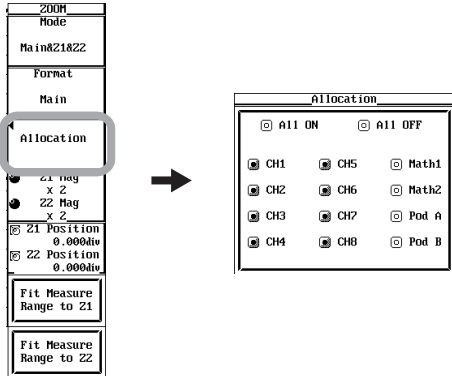

Setting the Zoom Rate

- 8. Press the **Z1 Mag/Z2 Mag** soft key to set the jog shuttle control to Z1 Mag. If you select Z1 on the Mode menu, Z1 Mag is displayed. If you select Z2, Z2 Mag is displayed. If you select Z1 and Z2, Z1 Mag/Z2 Mag is displayed.
- 9. Turn the **jog shuttle** to set the zoom rate of zoom box Z1.
- 10. Likewise, set the zoom rate of zoom box Z2 with Z2 Mag.
 - If you select Z1 Mag, you can set the zoom rate of Z1.
 - If you select Z2 Mag, you can set the zoom rate of Z2.
 - If you select both Z1 Mag and Z2 Mag, the zoom rate of Z2 is set equal to Z1. When you turn the jog shuttle, both are set to the same zoom rate.



Setting the Zoom Position

11. Press the **Z1 Position/Z2 Position** soft key to set the jog shuttle control to Z1 Position.
If you select Z1 on the Mode menu, Z1 Position is displayed. If you select Z2, Z2 Position is displayed. If you select Z1 and Z2, Z1 Position/Z2 Position is displayed.
12. Turn the **jog shuttle** to set the zoom position of zoom box Z1.
13. Likewise, set the zoom position of zoom box Z2 with Z2 Position.
 - If you select Z1 Position, you can move the zoom position of Z1.
 - If you select Z2 Position, you can move the zoom position of Z2.
 - If you select both Z1 Position and Z2 Position, the zoom positions of Z1 and Z2 can be moved without changing the spacing between the two. The value of the digit being specified by Z1 Position changes.



Setting the Range of the Automated Measurement of Waveform Parameters to Match the Zoom Range

14. Press the **Fit Meas Range to Z1** or **Fit Meas Range to Z2** soft key. The range of the automated measurement of waveform parameters is set to the zoom range of Z1 or Z2.

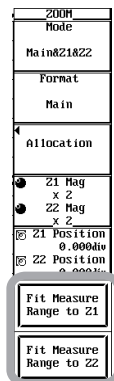

Explanation

Zoomed waveforms of two locations can be displayed simultaneously (dual zoom). You can also specify which channels to zoom. Zoom is possible until the number of displayed points is 50 (40 depending on the time axis setting).

Zoom Mode (Display Method of Zoomed Waveforms)

Main	Displays only the main (unzoomed) waveform.
Z1 Only	Displays only the zoomed waveform of zoom box Z1.
Z2 Only	Displays only the zoomed waveform of zoom box Z2.
Main&Z1	Displays the main waveform in the top window and zoomed waveform of zoom box Z1 in the bottom window.
Main&Z2	Displays the main waveform in the top window and zoomed waveform of zoom box Z2 in the bottom window.
Z1&Z2	Displays the zoomed waveform of zoom box Z1 in the top window and the zoomed waveform of zoom box Z2 in the bottom window.
Main&Z1&Z2	Displays the main waveform in the top window, the zoomed waveform of zoom box Z1 in the lower left window and the zoomed waveform of zoom box Z2 in the lower right window.

Zoomed Waveforms

Waveforms whose Allocation had been turned ON (CH1 to CH8, Math1, Math2, PodA, and Pod B) are zoomed. Waveforms whose Allocation had been turned OFF are not zoomed. You cannot zoom waveforms whose display is turned OFF.

Display Format of Zoomed Waveforms

Like the main waveform, 7 types (Main¹, Single, Dual, Triad, Quad, Hexa, and Octal²) of display formats are available. You cannot set different formats for Z1 and Z2.

- 1 If you select Main, the zoom waveform display frame is set to the same display format as the Format setting of the DISPLAY menu.
- 2 Octal can be used on the DL7480.

Zoom Rate

- The upper limit of the zoom rate is determined from the display record length as follows:

$$\text{Upper limit of zoom rate} = \frac{\text{Display record length}}{50 \text{ (or 40)}}$$
 - The display record length does not necessarily match the record length.
 - For details on the display record length, see appendix 1.
- You can set different zoom rates for Z1 and Z2 (zoomed waveform of two locations).

Zoom Position

- The zoom position can be set by specifying the zoom center position (center of the zoom box) in the range of -5 to +5 divisions with the center of the waveform display frame set to 0 divisions. However, when the record length is 16 MW, the zoom position can be set only in the range in which the edge of the waveform matches the edge of the window. The resolution is 10 divisions÷the display record length.
- The zoom box enclosed by solid lines is Z1 and the one enclosed by dashed lines is Z2. Since each box is independent, you can set the position separately.

Range of the Automated Measurement of Waveform Parameters and Zoom Range

Sets the measurement range of the automated measurement of waveform parameters to the zoom range of Z1 or Z2. This setting is active even when the automated measurement of waveform parameters is turned OFF.

8.5 Displaying X-Y Waveforms

<For a description of this function, refer to page 2-19.>

Procedure

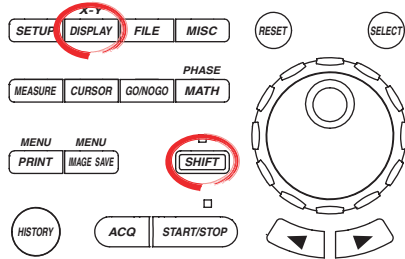

- To exit the menu during operation, press **ESC** located above the soft keys.
- For a description of the operation using a USB keyboard or a USB mouse, see section 4.3.

Selecting the Display Mode

1. Press **SHIFT+DISPLAY(X-Y)**. The X-Y menu appears.
2. Press the **Mode** soft key. The Mode menu appears.
3. Press the **T-Y, X-Y, or T-Y&X-Y** soft key to select the mode.

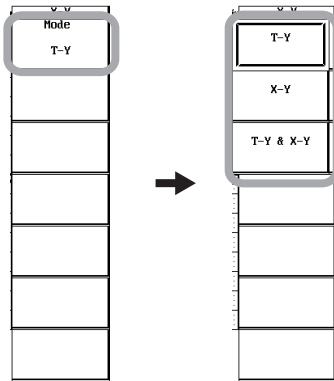

Steps 4 to 11 are necessary only when X-Y or T-Y&X-Y is selected.

Selecting the X-Axis Mode

4. Press the **X Axis** soft key to select Single or Dual.

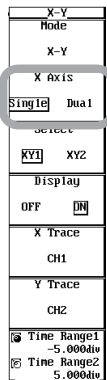

Selecting the X-Y Waveform

- Press the **Select** soft key to select the X-Y waveform to be set.
- Press the **Display** soft key to turn ON/OFF the X-Y waveform display.

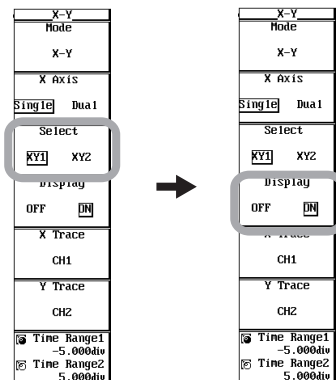

Setting the X-Axis and Y-Axis

- Press the **X Trace** soft key. The X Trace menu appears.
- Select the waveform to be assigned to the X-axis.
- Press the **Y Trace** soft key. The Y Trace menu appears.
- Select the waveform to be assigned to the Y-axis.

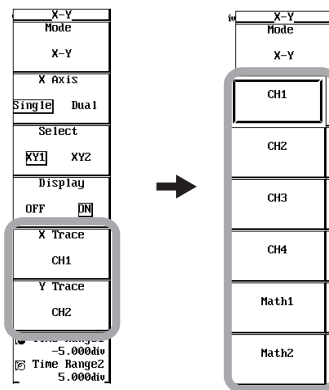

Setting the Display Range

- Press the **Time Range1/Time Range2** soft key to set the jog shuttle control to Time Range1, Time Range2, or both Time Range1 and Time Range 2.
 - If you select Time Range1, you can set the start point of the X-Y waveform display.
 - If you select Time Range2, you can set the end point of the X-Y waveform display.
 - If you select both Time Range1 and Time Range2, you can move the start and end points of the X-Y waveform display without changing the spacing between the two. The value of the digit being specified by Time Range1 changes.
- Turn the **jog shuttle** to set the start and end points of the X-Y waveform display.

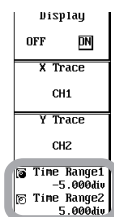

Explanation

Display Mode

You can select the display mode.

T-Y&X-Y	The top window displays T-Y (normal) waveforms. The bottom window displays X-Y waveforms.
X-Y	Displays only X-Y waveforms.
T-Y	Displays only T-Y waveforms.

X-Axis Mode

You can select the X-axis mode.

Single	Sets the X-axis trace of XY1 and XY2 common.
Dual	Sets the X-axis trace of XY1 and XY2 separately.

Number of X-Y Waveforms That Can Be Displayed

The number of X-Y waveforms that can be displayed is 2 (XY1 and XY2). The display of each X-Y waveform can be turned ON/OFF.

Assigning the X-Axis (Horizontal Axis) and Y-Axis (Vertical Axis)

The channels that can be assigned to the X and Y axes depending on the X-axis mode are as follows:

X Axis Mode	X-Y Waveform	X-Axis	Y-Axis
Single	XY1	CH1 to CH4, Math1, Math2	CH1, CH2, and Math1
	XY2	CH1 to CH4, Math1, Math2	CH3, CH4, and Math2
Dual	XY1	CH1, CH2, Math1	CH1, CH2, and Math1
	XY2	CH3, CH4, Math2	CH3, CH4, and Math2

X-Y Waveform Display Range

The X-Y waveform displays the range specified on the T-Y waveform. You can set the start (fine dashed line) and end (coarse dashed line) positions in the range of -5 to +5 divisions from the center of the waveform display frame. The start and end points are not displayed if only X-Y waveforms are displayed. The resolution is 10 divisions÷the display record length.

Note

- The divided windows of the T-Y waveform display when using the T-Y & X-Y mode are displayed according to Format in the DISPLAY menu.
- The zoom function applies only to T-Y waveforms. In addition, Main, Z1, or Z2 can be selected for the T-Y waveform display.
- To expand the X-Y waveform, change the Variable setting of each channel. The displayed waveform can be enlarged/reduced in a simulated fashion.

8.6 Taking Snapshots and Clearing Traces

<For a description of this function, refer to page 2-20.>

Procedure

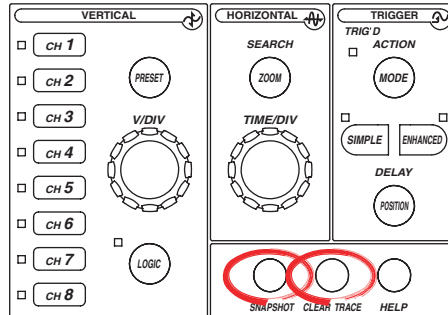

For a description of the operation using a USB keyboard or a USB mouse, see section 4.3.

Taking a Snapshot

Press **SNAPSHOT** to take a snapshot of the screen.

Executing Clear Trace

Press **CLEAR TRACE** to clear the waveform.

Explanation

Snapshot

The snapshot function leaves the current displayed waveform on the screen. You can update the display without stopping the waveform acquisition. This function is useful in situations such as when you wish to compare waveforms.

- You cannot perform the following operations on snapshot waveforms.
Cursor measurements, automated measurement of waveform parameters, zoom, and computation
- Snapshot waveforms can be saved and loaded in bitmap format. For details, see section 12.9.

Clearing Traces

- You can clear all the waveforms that are currently displayed on the screen.
- If you execute CLEAR TRACE when waveforms are being acquired, waveform acquisition is restarted (from the first acquisition).
- Loaded waveforms are not cleared. To clear loaded waveforms, perform an unload operation (see section 12.8).

Conditions That Disable the SNAPSHOT and CLEAR TRACE Keys

- When engaging remote mode using the communication interface.
- When printing, during auto setup, and while the storage medium is being accessed.
- When GO/NO-GO determination, action-on-trigger, or waveform search is in progress.

8.7 Changing the Graticule

Procedure

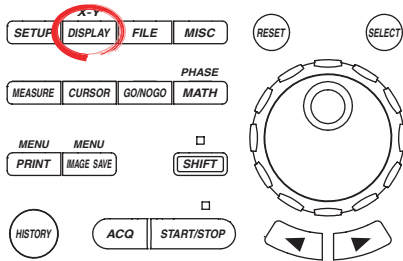

- To exit the menu during operation, press **ESC** located above the soft keys.
- For a description of the operation using a USB keyboard or a USB mouse, see section 4.3.

1. Press **DISPLAY**. The DISPLAY menu appears.
2. Press the **Graticule** soft key to select the graticule.

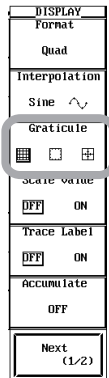

Explanation

You can select the graticule.

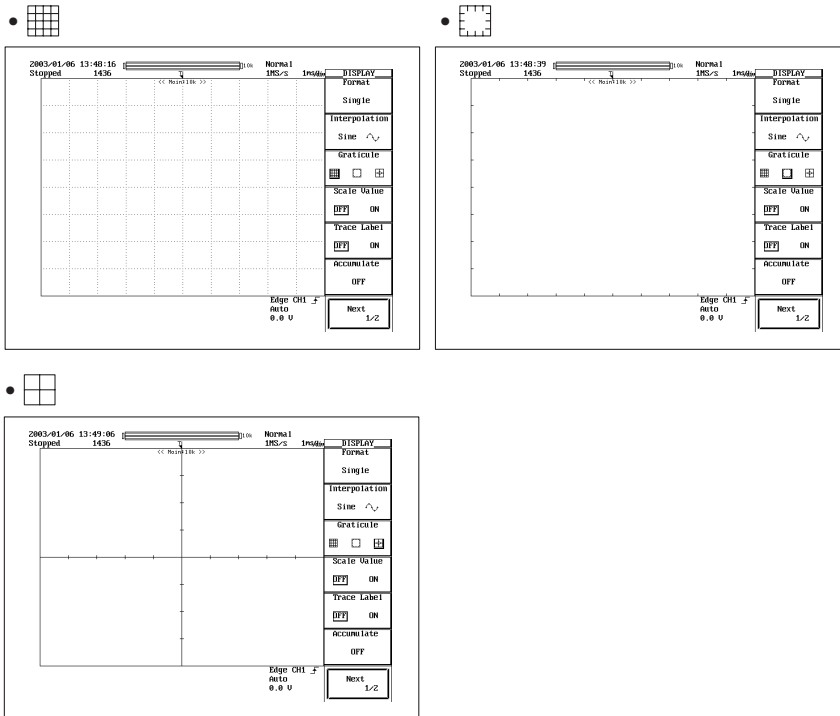

8.8 Turning ON/OFF the Scale Display

Procedure

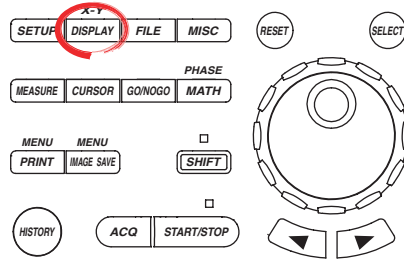

- To exit the menu during operation, press **ESC** located above the soft keys.
- For a description of the operation using a USB keyboard or a USB mouse, see section 4.3.

1. Press **DISPLAY**. The DISPLAY menu appears.
2. Press the **Scale Value** soft key to select ON or OFF.

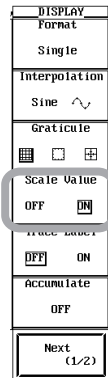

Explanation

The display of upper and lower limits of the vertical and horizontal axis of each channel can be turned ON/OFF. For display examples, see page 1-6.

8.9 Setting Waveform Labels and Turning ON/OFF the Display

Procedure

Setting Waveform Labels

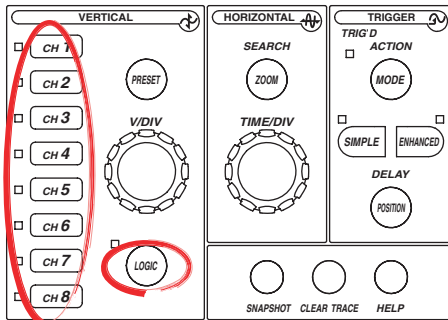

- To exit the menu during operation, press **ESC** located above the soft keys.
- For a description of the operation using a USB keyboard or a USB mouse, see section 4.3.

Setting Waveform Labels for CH1 to CH8

- Press one of the **CH1** to **CH8/4** keys to select the channel to which a waveform label is to be assigned.
You can select up to CH4 and CH8 on the DL7440 and DL7480, respectively.
- Press the **Next (1/2)** soft key. The page 2 menu appears.
- Press the **Label** soft key. A keyboard used to enter values and strings appears.
- Use **jog shuttle & SELECT** to set the waveform label.

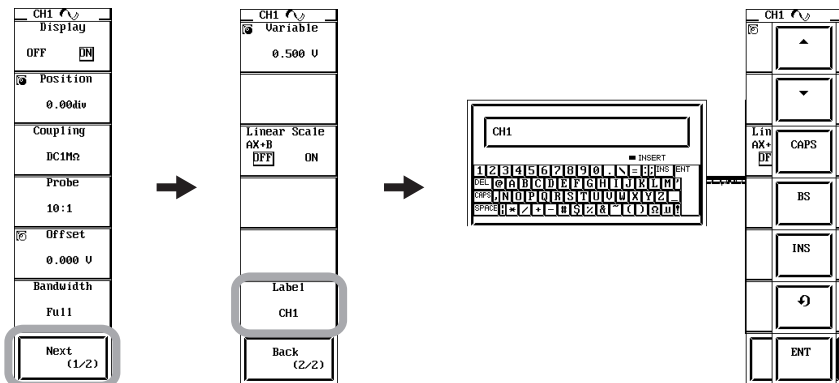

Setting LOGIC Waveform Labels

- Press **LOGIC**. The LOGIC menu appears.
- Press the **Label** soft key. The Label dialog box opens.
- Use **jog shuttle & SELECT** to select the bit to which the waveform label is to be assigned. A keyboard used to enter values and strings appears.
- Use **jog shuttle & SELECT** to set the waveform label.

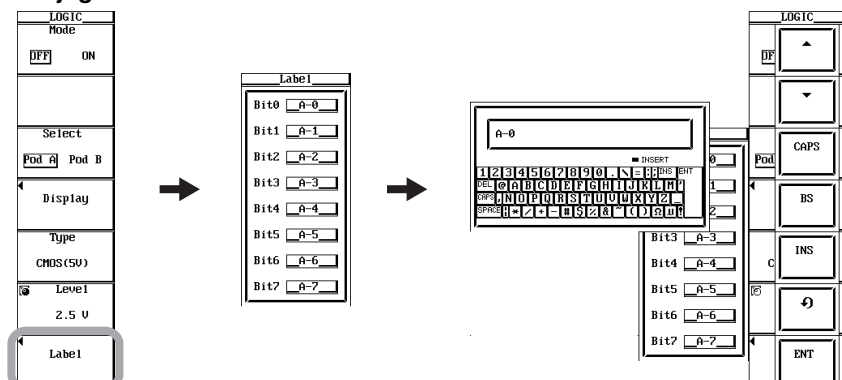

Turning ON/OFF the Waveform Label Display

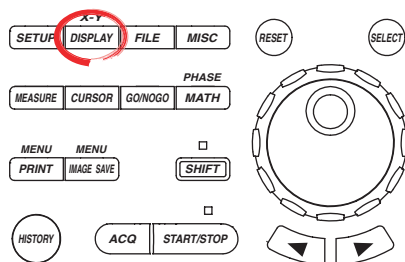

- To exit the menu during operation, press **ESC** located above the soft keys.
- For a description of the operation using a USB keyboard or a USB mouse, see section 4.3.

1. Press **DISPLAY**. The DISPLAY menu appears.
2. Press the **Trace Label** soft key to select ON or OFF.

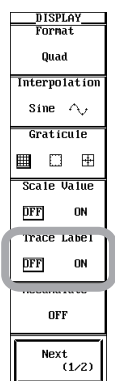

Explanation

Waveform Labels

You can arbitrary set the waveform label of each channel using up to eight characters. The label is applied to Trace Label.

Turning ON/OFF the Waveform Label Display

You can select whether to display the label assigned to the channel of the displayed waveform. For display examples, see page 1-6.

8.10 Turning ON/OFF the Translucent Display

Procedure

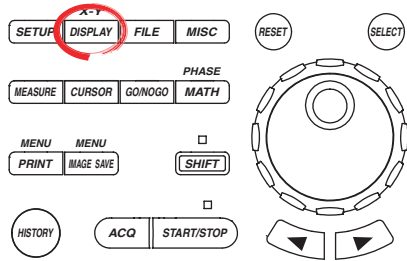

- To exit the menu during operation, press **ESC** located above the soft keys.
- For a description of the operation using a USB keyboard or a USB mouse, see section 4.3.

1. Press **DISPLAY**. The DISPLAY menu appears.
2. Press the **Next (1/2)** soft key. The page 2 menu appears.
3. Press the **Translucent** soft key to select ON or OFF.

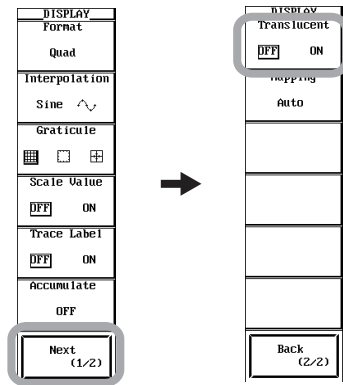

Explanation

When this is turned to ON, dialog boxes become translucent. The contents underneath the dialog boxes can be seen.

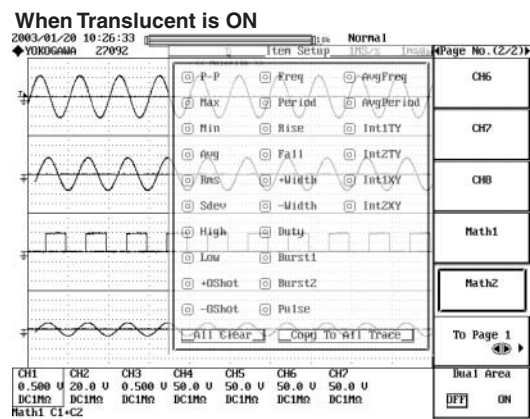
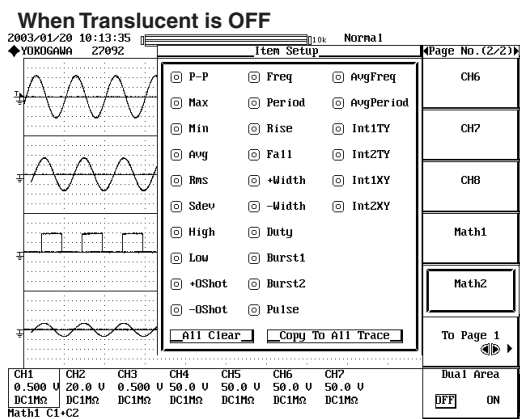

9.1 Entering Normal Computation Mode, Displaying Computed Waveforms, and Assigning Labels to Computed Waveforms

Procedure

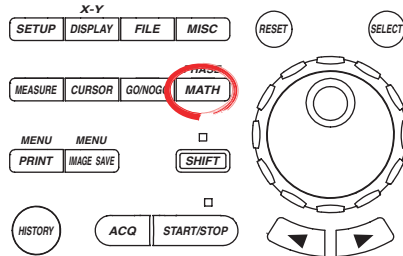

- To exit the menu during operation, press **ESC** located above the soft keys.
- In the procedural explanation below, the term *jog shuttle & SELECT* refers to the operation of selecting/setting items and entering values using the **jog shuttle** and **SELECT** and **RESET** keys. For details on this operation, see sections 4.1 or 4.2.
- For a description of the operation using a USB keyboard or a USB mouse, see section 4.3.

Note

Steps 3 to 5 describe the setup procedures for computed waveform Math1. Perform similar steps for Math2.

- If the user-defined computation option is installed, start from step 1. You must first enter normal computation mode.
- If the user-defined computation option is not installed, start from step 3.

Entering Normal Computation Mode

If the user-defined computation option is installed, select normal computation mode.

1. Press **MATH**. The MATH menu appears.
2. Press the **Math Mode** soft key to select Normal. The normal computation menu appears.

If you select User, user-defined computation mode is enabled. For a description of the procedure, see section 9.9.

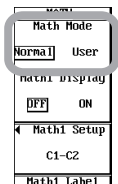

Turning ON/OFF the Computed Waveforms

3. Press the **Math1 Display** soft key to select ON or OFF.
 - If ON is selected, the Math1 waveform is displayed.
 - If OFF is selected, the Math1 waveform is not displayed.

When the user-defined computation option is installed

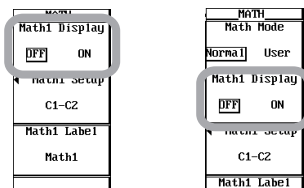

Assigning Labels to Computed Waveforms

4. Press **Math1 Label**. A keyboard used to enter values and strings appears.
5. Use **jog shuttle & SELECT** to set the label.

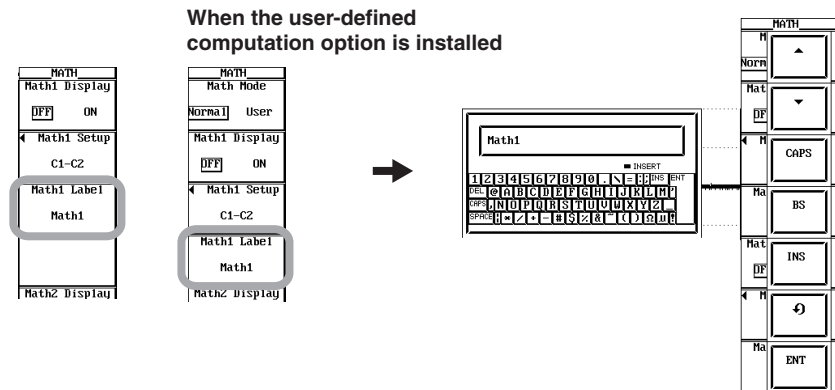

Explanation

This section describes the setup procedures that are common to the computations described in section 9.2 to 9.8.

Switching the Computation Mode

If the user-defined computation option is installed, the computation mode can be switched.

Normal

Switches to normal computation mode, and a menu for normal computation appears. For a description of the setup procedure of the normal computation equation and the procedure for displaying the waveform, see sections 9.2 to 9.8.

User

Switches to user-defined computation mode, and a menu for user-defined computation appears. For a description of the setup procedure of user-defined computation, see section 9.9.

Turning ON/OFF the Computed Waveform Display

The display of the computed waveforms Math1 and Math2 can be turned ON/OFF separately.

ON

Computed waveforms are displayed.

OFF

Computed waveforms are not displayed.

Computed Waveform Labels

Labels can be assigned to computed waveforms Math1 and Math2 using up to 8 characters.

- The type of characters that can be used are those displayed on the keyboard.
- For the procedure of turning ON/OFF the display of the assigned labels, see section 8.9.

9.2 Adding, Subtracting, and Multiplying Waveforms

Procedure

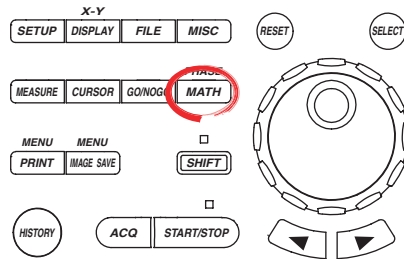

- To exit the menu during operation, press **ESC** located above the soft keys.
- In the procedural explanation below, the term *jog shuttle & SELECT* refers to the operation of selecting/setting items and entering values using the **jog shuttle** and **SELECT** and **RESET** keys. For details on this operation, see sections 4.1 or 4.2.
- For a description of the operation using a USB keyboard or a USB mouse, see section 4.3.

Note

- If the user-defined computation option is installed, you must first enter normal computation mode as described in section 9.1.
- This section describes the setup procedures for computed waveform Math1. Perform similar steps for Math2.

1. Press the **Math1 Setup** soft key. The Math1 Setup dialog box opens.

When the user-defined computation option is installed

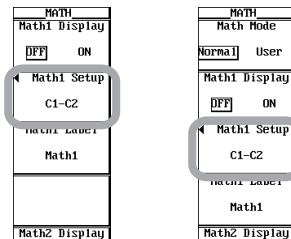

Setting the Equation, Scaling, Unit, and Smoothing

2. Use **jog shuttle & SELECT** to select the operator (+, -, or *) and the waveform on which to perform computation.

When the Math1 Setup dialog box is closed by pressing **ESC** or another key, the specified equation appears in the Math1 Setup menu column.
3. Use **jog shuttle & SELECT** to set the scaling, unit, and smoothing of computed waveform Math1.
4. Press **ESC**. The Math1 Setup dialog box closes.

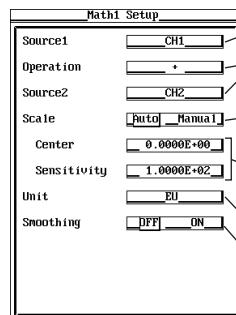

- Select the waveform on which to perform computation.
- Select the operator from +, -, and *.
- Set the scaling used to display computed waveform Math1 to Auto (auto scaling) or Manual (manual scaling).
- If scaling is set to Manual, set the vertical center line level on the screen (voltage value if set to voltage) and the sensitivity (voltage per division if set to voltage).
- Set the unit of computed waveform Math1.
- Turn ON/OFF zooming.

9.2 Adding, Subtracting, and Multiplying Waveforms

Explanation

This section describes the procedures for selecting addition, subtraction, or multiplication in normal computation mode. If the user-defined computation option is installed, you must first enter normal computation mode as described in section 9.1. For a description of the setup procedure for user-defined computation, see section 9.9.

Turning ON/OFF the Computed Waveform Display

The display of the computed waveforms Math1 and Math2 can be turned ON/OFF separately. For details, see section 9.1.

Operator

Select the addition, subtraction, or multiplication operator (+, −, or ×) as the operator of Math1 and Math2. Addition, subtraction, and multiplication can be performed between the waveforms to be computed.

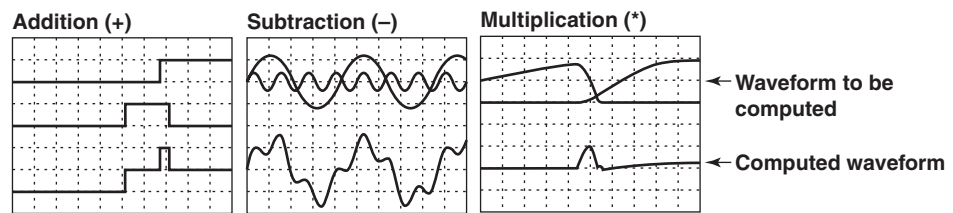

Waveform to Be Computed

The waveforms on which computation can be performed are as follows:

Computation Name	Source1	Source2
Math1	CH1 or CH2	One channel from CH1 to CH4
Math2	CH3 or CH4	One channel from CH1 to CH4 and Math1

- On the menu, CH1 to CH4 may be indicated as C1 to C4 and Math1 as M1.
- To perform computation on CH5 to CH8 on the DL7480, the optional user-defined computation function is required.

Scaling

Scaling used to display computed waveforms Math1 and Math2 can be selected separately.

Auto

Set to auto scaling. The vertical center line level (voltage value if set to voltage) of the display frame and the sensitivity (voltage value per division if set to voltage) are automatically determined to display the computed waveform.

Manual

Set to manual scaling. The following items can be specified as necessary to display the computed waveform. The selectable range is $-9.9999E+30$ to $9.9999E+30$.

- Center
The vertical center line level (voltage value if set to voltage) of the display frame can be specified.
- Sensitivity
The sensitivity (voltage value per division if set to voltage) can be specified.

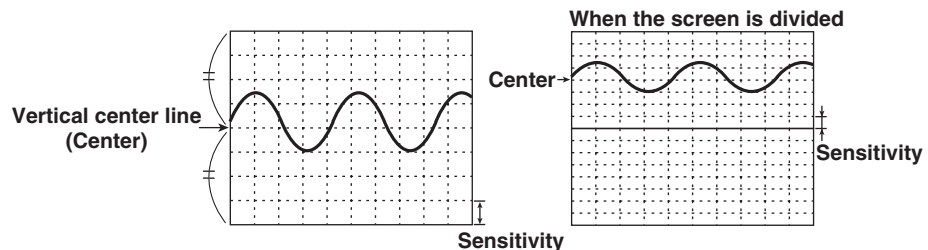

Note

If the scaling method is switched from manual to auto, the center and sensitivity values that you specified when in manual mode are set to auto scaled values.

Unit of Computed Waveforms

Units can be assigned to computed waveforms Math1 and Math2 using up to 4 characters.

- The type of characters that can be used are those displayed on the keyboard.
- The specified unit is displayed along with the scaled value (section 8.8).

Smoothing

Smoothing refers to the operation of deriving the weighted moving average every five points of the waveform to be computed. Since the process is performed on the waveform data stored in the acquisition memory, it can be performed even when acquisition is stopped. Smoothing has the frequency characteristics shown in the following diagram with respect to the sample rate. The -3 dB point is at approximately 13% of the sample rate.

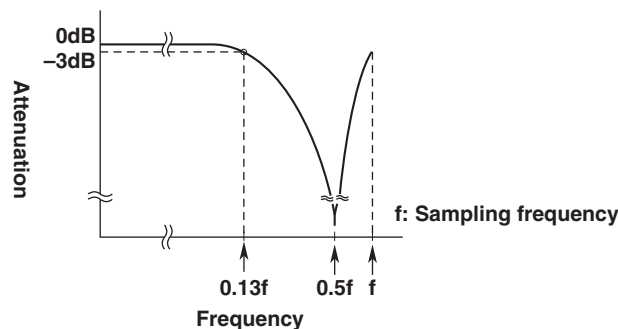

- You can select whether to perform computation using the smoothed waveform data for computed waveforms Math1 and Math2, separately.

ON

Perform computation using the smoothed waveform data.

OFF

Perform computation using the waveform data that is not smoothed.

- The smoothing setting applies to all computations of addition, subtraction, multiplication, binary computation, waveform inversion, differentiation, and integration. If the smoothing setting is changed on one of the computation settings, the change takes effect on all other computations (addition, subtraction, multiplication, binary computation, waveform inversion, differentiation, and integration). However, Math1 and Math2 can be set separately.

Effects of Linear Scaling

If linear scaling is performed on the channel to be computed, computation is performed using linearly scaled values.

Maximum Record Length That Can Be Computed

The maximum record lengths that can be computed on Math1 and Math2 are as follows:

- On 4 MW memory models (701450 and 701470), the maximum record length is 4 MW.
- On 16 MW memory models (701460 and 701480), the record length is 8 MW and 4 MW when interleave mode is ON and when interleave mode is OFF, respectively.

Computed Waveform Labels

Labels can be assigned to computed waveforms Math1 and Math2 using up to 8 characters. For details, see section 9.1.

9.3 Performing Binary Computation

Procedure

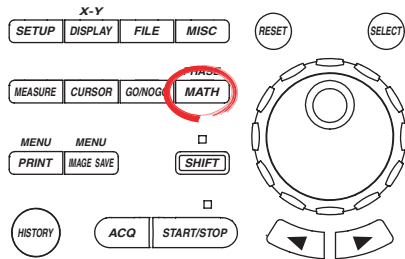

- To exit the menu during operation, press **ESC** located above the soft keys.
- In the procedural explanation below, the term *jog shuttle & SELECT* refers to the operation of selecting/setting items and entering values using the **jog shuttle** and **SELECT** and **RESET** keys. For details on this operation, see sections 4.1 or 4.2.
- For a description of the operation using a USB keyboard or a USB mouse, see section 4.3.

Note

- If the user-defined computation option is installed, you must first enter normal computation mode as described in section 9.1.
- The setup procedures for computed waveform Math1 are described below. Perform similar steps for Math2.

1. Press the **Math1 Setup** soft key. The Math1 Setup dialog box opens.

When the user-defined computation option is installed

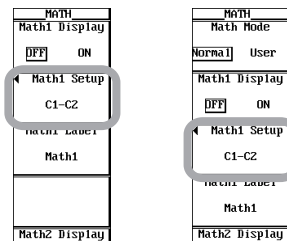

Setting the Equation, Unit, Smoothing, and Threshold Level for Binary Computation

2. Use **jog shuttle & SELECT** to select the operator for binary computation (Bin) and the waveform on which to perform computation.
When the Math1 Setup dialog box is closed by pressing **ESC** or another key, the specified equation appears in the Math1 Setup menu column.
3. Use **jog shuttle & SELECT** to set the unit, smoothing, and level when performing binary computation (convert into 0s and 1s) of computed waveform Math1.
4. Press **ESC**. The Math1 Setup dialog box closes.

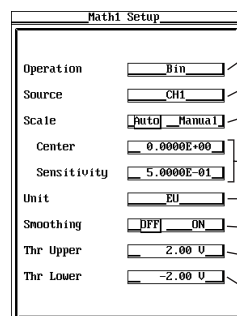

- Select Bin.
- Select the waveform on which to perform computation.
- Scaling used to display computed waveform Math1 cannot be selected.
- The scaling level is fixed. It cannot be changed.
- Set the unit of computed waveform Math1.
- Turn ON/OFF zooming.
- Set the level of computed waveform Math1 used to switch from 0 to 1.
- Set the level of computed waveform Math1 used to switch from 1 to 0.

Explanation

This section describes the procedures for setting the binary computation in normal computation mode. If the user-defined computation option is installed, you must first enter normal computation mode as described in section 9.1. For a description of the setup procedure of user-defined computation, see section 9.9.

Turning ON/OFF the Computed Waveform Display and Computed Waveform Label

See section 9.1.

Operator

Select the binary computation operator Bin as the operator of Math1 and Math2. The waveform to be computed can be converted to a digital waveform of 0s and 1s with respect to the specified threshold level.

Waveform to Be Computed

The waveforms on which computation can be performed are as follows:

Computation Name	Source
Math1	One channel from CH1 to CH4
Math2	One channel from CH1 to CH4 and Math1

- On the menu, CH1 to CH4 may be indicated as C1 to C4 and Math1 as M1.
- To perform computation on CH5 to CH8 on the DL7480, the optional user-defined computation function is required.

Scaling

Scaling is not available in binary computation. You can select Auto or Manual on the menu, but the computed result is not affected. The scaling level is fixed.

Unit of Computed Waveforms

The operation is the same as for addition, subtraction, and multiplication. See section 9.2.

Smoothing

The operation is the same as for addition, subtraction, and multiplication. See section 9.2.

Threshold Level for Binary Computation

You can set the level (voltage value if set to voltage) for setting the data values to 1 or 0 in binary computation for computed waveforms Math1 and Math2, separately (see the figure above). The range is 8 divisions within the screen. The resolution is 0.01 divisions.

Thr Upper	Set the level used to switch from 0 to 1.
Thr Lower	Set the level used to switch from 1 to 0.

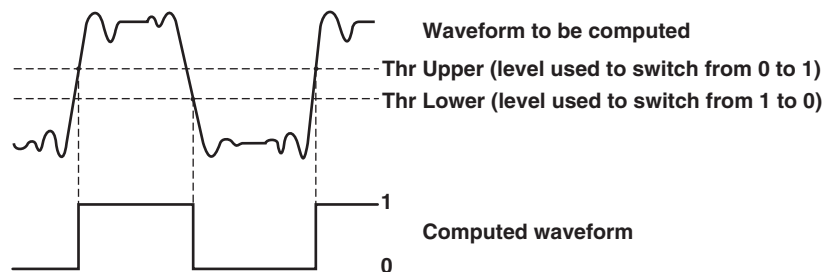

Effects of Linear Scaling

Even when linear scaling is performed on the channel to be computed, it does not affect the binary computation.

Maximum Record Length That Can Be Computed

The operation is the same as for addition, subtraction, and multiplication. See section 9.2.

9.4 Inverting Waveforms

Procedure

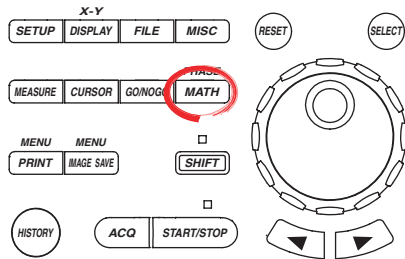

- To exit the menu during operation, press **ESC** located above the soft keys.
- In the procedural explanation below, the term *jog shuttle & SELECT* refers to the operation of selecting/setting items and entering values using the **jog shuttle** and **SELECT** and **RESET** keys. For details on this operation, see sections 4.1 or 4.2.
- For a description of the operation using a USB keyboard or a USB mouse, see section 4.3.

Note

- If the user-defined computation option is installed, you must first enter normal computation mode as described in section 9.1.
- The setup procedures for computed waveform Math1 are described below. Perform similar steps for Math2.

1. Press the **Math1 Setup** soft key. The Math1 Setup dialog box opens.

When the user-defined computation option is installed

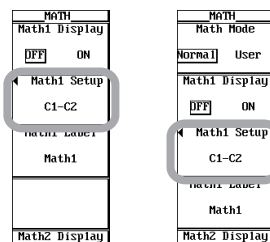

Setting the Equation, Scaling, Unit, and Smoothing

2. Use **jog shuttle & SELECT** to select the inversion operator (Invert) and the waveform on which to perform computation.

When the Math1 Setup dialog box is closed by pressing **ESC** or another key, the specified equation appears in the Math1 Setup menu column.
3. Use **jog shuttle & SELECT** to set the scaling, unit, and smoothing of computed waveform Math1.
4. Press **ESC**. The Math1 Setup dialog box closes.

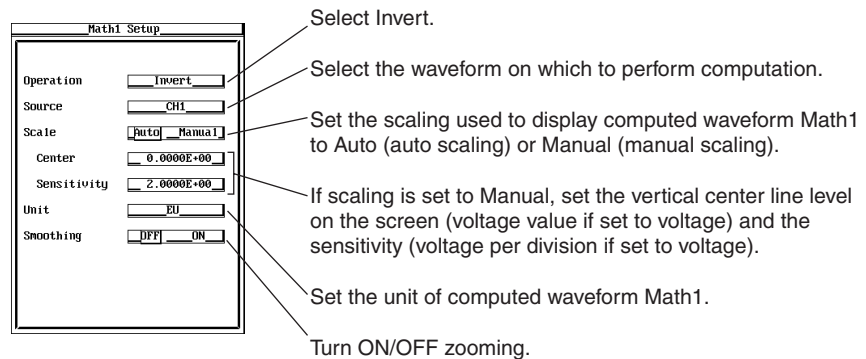

Explanation

This section describes the procedure for setting the computation that inverts waveforms in normal computation mode. If the user-defined computation option is installed, you must first enter normal computation mode as described in section 9.1. For a description of the setup procedure of user-defined computation, see section 9.9.

Turning ON/OFF the Computed Waveform Display and Computed Waveform Label

See section 9.1.

Operator

Select the inversion operator Invert as the operator for Math1 and Math2. The waveform to be computed is inverted vertically (around the 0 level of the waveform) by multiplying the waveform data by -1 .

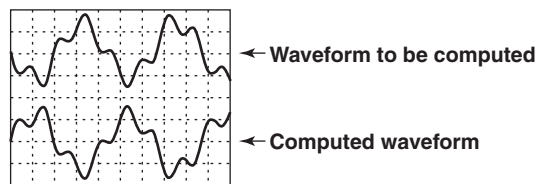
**Waveform to Be Computed**

The waveforms on which computation can be performed are as follows.

Computation Name	Source
Math1	One channel from CH1 to CH4
Math2	One channel from CH1 to CH4 and Math1

- On the menu, CH1 to CH4 may be indicated as C1 to C4 and Math1 as M1.
- To perform computation on CH5 to CH8 on the DL7480, the optional user-defined computation function is required.

Scaling

The operation is the same as for addition, subtraction, and multiplication. See section 9.2.

Unit of Computed Waveforms

The operation is the same as for addition, subtraction, and multiplication. See section 9.2.

Smoothing

The operation is the same as for addition, subtraction, and multiplication. See section 9.2.

Effects of Linear Scaling

The operation is the same as for addition, subtraction, and multiplication. See section 9.2.

Maximum Record Length That Can Be Computed

The operation is the same as for addition, subtraction, and multiplication. See section 9.2.

9.5 Differentiating and Integrating Waveforms

Procedure

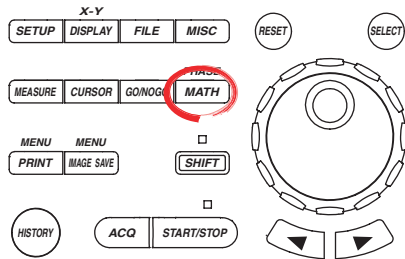

- To exit the menu during operation, press **ESC** located above the soft keys.
- In the procedural explanation below, the term *jog shuttle & SELECT* refers to the operation of selecting/setting items and entering values using the **jog shuttle** and **SELECT** and **RESET** keys. For details on this operation, see sections 4.1 or 4.2.
- For a description of the operation using a USB keyboard or a USB mouse, see section 4.3.

Note

- If the user-defined computation option is installed, you must first enter normal computation mode as described in section 9.1.
- The setup procedures for computed waveform Math1 are described below. Perform similar steps for Math2.

1. Press the **Math1 Setup** soft key. The Math1 Setup dialog box opens.

When the user-defined computation option is installed

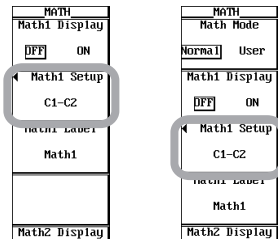

Setting the Equation, Scaling, Unit, Smoothing, and Integration Start Point

2. Use **jog shuttle & SELECT** to select the differentiation or integration operator (Diff or Integ) and the waveform on which to perform computation.
When the Math1 Setup dialog box is closed by pressing **ESC** or another key, the specified equation appears in the Math1 Setup menu column.
3. Use **jog shuttle & SELECT** to set the scaling, unit, and smoothing of computed waveform Math1.
4. If the integration operator Integ is selected, use **jog shuttle & SELECT** to set the start point of integration.
5. Press **ESC**. The Math1 Setup dialog box closes.

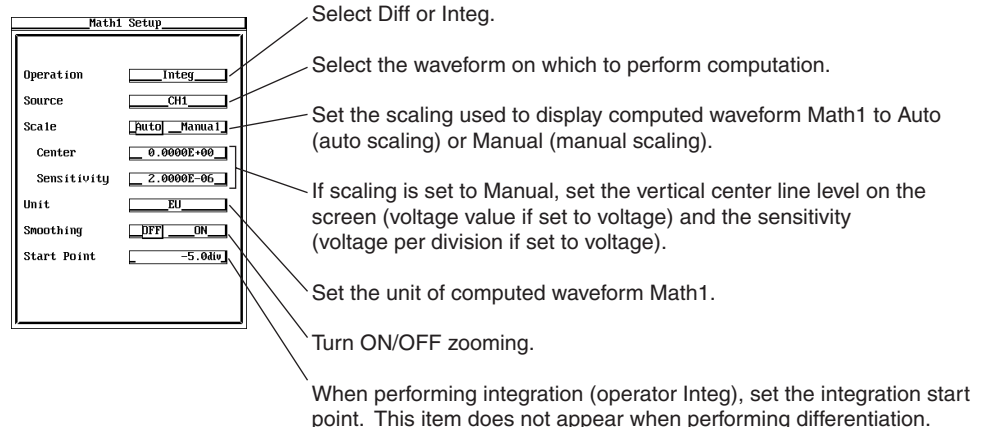

Explanation

This section describes the procedures for setting the differentiation or integration computation in normal computation mode. If the user-defined computation option is installed, you must first enter normal computation mode as described in section 9.1. For a description of the setup procedure of user-defined computation, see section 9.9.

Turning ON/OFF the Computed Waveform Display and Computed Waveform Label

See section 9.1.

Operator

Select the differentiation operator Diff or integration operator Integ as the operator for Math1 and Math2. The waveform to be computed can be differentiated or integrated.

Waveform to Be Computed

The waveforms on which computation can be performed are as follows:

Computation Name	Source
Math1	One channel from CH1 to CH4
Math2	One channel from CH1 to CH4 and Math1

- On the menu, CH1 to CH4 may be indicated as C1 to C4 and Math1 as M1.
- To perform computation on CH5 to CH8 on the DL7480, the optional user-defined computation function is required.

Scaling

The operation is the same as for addition, subtraction, and multiplication. See section 9.2.

Unit of Computed Waveforms

The operation is the same as for addition, subtraction, and multiplication. See section 9.2.

Smoothing

The operation is the same as for addition, subtraction, and multiplication. See section 9.2.

Integration Start Point

You can set the start point of integration. The selectable range is ± 5 divisions, and the resolution is 10 divisions \div the display record length. For a description of the display record length, see appendix 1.

Effects of Linear Scaling

The operation is the same as for addition, subtraction, and multiplication. See section 9.2.

Maximum Record Length That Can Be Computed

The operation is the same as for addition, subtraction, and multiplication. See section 9.2.

9.6 Performing Power Spectrum Computation (FFT)

<For a description of this function, refer to page 2-22.>

Procedure

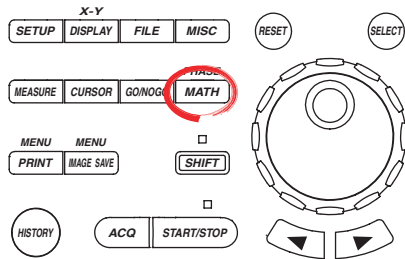

- To exit the menu during operation, press **ESC** located above the soft keys.
- In the procedural explanation below, the term *jog shuttle & SELECT* refers to the operation of selecting/setting items and entering values using the **jog shuttle** and **SELECT** and **RESET** keys. For details on this operation, see sections 4.1 or 4.2.
- For a description of the operation using a USB keyboard or a USB mouse, see section 4.3.

Note

- If the user-defined computation option is installed, you must first enter normal computation mode as described in section 9.1.
- The setup procedures for computed waveform Math1 are described below. Perform similar steps for Math2.

1. Press the **Math1 Setup** soft key. The Math1 Setup dialog box opens.

When the user-defined computation option is installed

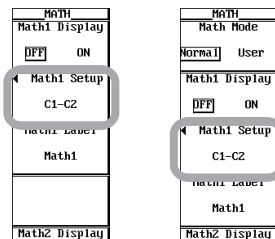

Setting the Equation, Scaling, Unit, Smoothing, Computation Start Point, the Number of Computed Points, and Time Window

2. Use **jog shuttle & SELECT** to select the power spectrum computation operator PS and the waveform on which to perform computation.
When the Math1 Setup dialog box is closed by pressing ESC or another key, the specified equation appears in the Math1 Setup menu column.
3. Use **jog shuttle & SELECT** to set the scaling, unit, computation start point, the number of computed points, and the time window of computed waveform Math1.
4. Press **ESC**. The Math1 Setup dialog box closes.

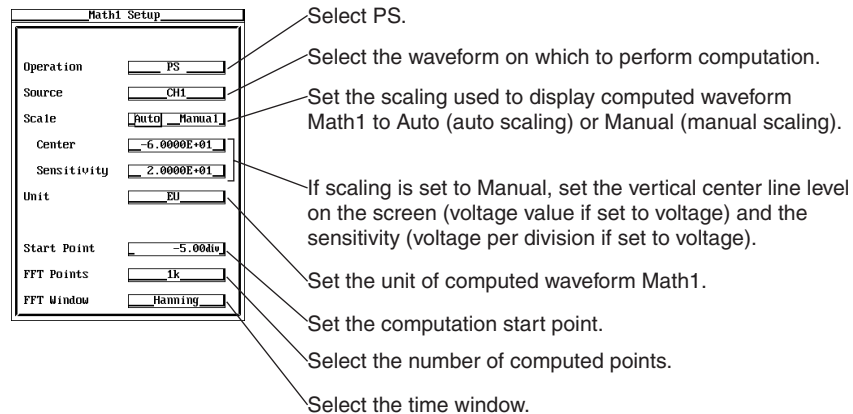

Explanation

This section describes the procedures for setting the power spectrum computation (FFT) in normal computation mode. If the user-defined computation option is installed, you must first enter normal computation mode as described in section 9.1. For a description of the setup procedure of user-defined computation, see section 9.9.

Note

An asterisk is displayed at the upper left corner of the screen while power spectrum computation is in progress.

Turning ON/OFF the Computed Waveform Display and Computed Waveform Label

See section 9.1.

Operator

Select the power spectrum computation operator PS as the operator of Math1 and Math2. The power spectrum of the waveform to be computed can be determined by taking the FFT (Fast Fourier Transform).

Waveform to Be Computed

The waveforms on which computation can be performed are as follows:

Computation Name	Source
Math1	One channel from CH1 to CH4
Math2	One channel from CH1 to CH4 and Math1

- On the menu, CH1 to CH4 may be indicated as C1 to C4 and Math1 as M1.
- To perform computation on CH5 to CH8 on the DL7480, the optional user-defined computation function is required.

Scaling

The operation is the same as for addition, subtraction, and multiplication. See section 9.2.

Unit of Computed Waveforms

The operation is the same as for addition, subtraction, and multiplication. See section 9.2.

Computation Start Point

You can set the point where power spectrum computation is to start. The selectable range is ± 5 divisions, and the resolution is 10 divisions \div the display record length. For a description of the display record length, see appendix 1.

Number of Computed Points

You can select 1 kW or 10 kW.

9.6 Performing Power Spectrum Computation (FFT)

Selecting the Time Window

You can select the time window.

Rect (Rectangular)

Best suited for transient signals that attenuate completely within the time window.

Hanning

Best suited for continuous and non-periodic signals.

Flattop

Best suited for improving the accuracy of the level even if the frequency resolution is to be compromised.

Effects of Linear Scaling

If linear scaling is performed on the channel to be computed, computation is performed using the linearly scaled values and affects the level of the power spectrum computation result.

Maximum Record Length That Can Be Computed

The operation is the same as for addition, subtraction, and multiplication. See section 9.2.

Note

- The power spectrum cannot be computed, if the displayed record length is less than number of computed points. In addition, it cannot be computed when the number of data points after the computation start point is less than the number of computed points.
 - Power spectrum computation is performed on the data stored in the acquisition memory. For waveforms acquired in envelope mode, computation is performed on the maximum and minimum values per acquisition interval
-

9.7 Smoothing Waveforms

Procedure

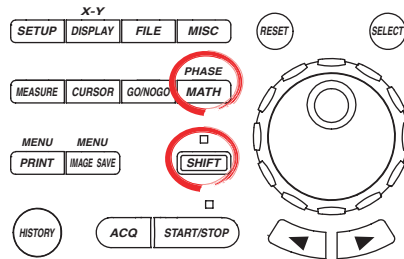

- To exit the menu during operation, press **ESC** located above the soft keys.
- In the procedural explanation below, the term *jog shuttle & SELECT* refers to the operation of selecting/setting items and entering values using the **jog shuttle** and **SELECT** and **RESET** keys. For details on this operation, see sections 4.1 or 4.2.
- For a description of the operation using a USB keyboard or a USB mouse, see section 4.3.

Note

- If the user-defined computation option is installed, you must first enter normal computation mode as described in section 9.1.
- The setup procedures for computed waveform Math1 are described below. Perform similar steps for Math2.

1. Press the **Math1 Setup** soft key. The Math1 Setup dialog box opens.

When the user-defined computation option is installed

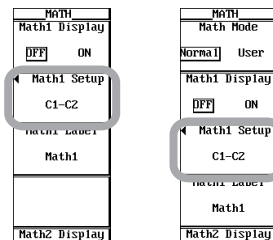

Setting the Equation, Scaling, Unit, and Smoothing

2. Use **jog shuttle & SELECT** to select the Pass-Thru operator and the waveform on which to perform computation.

When the Math1 Setup dialog box is closed by pressing **ESC** or another key, the specified equation appears in the Math1 Setup menu column.
3. Use **jog shuttle & SELECT** to set the scaling, unit, and smoothing of computed waveform Math1.
4. Press **ESC**. The Math1 Setup dialog box closes.

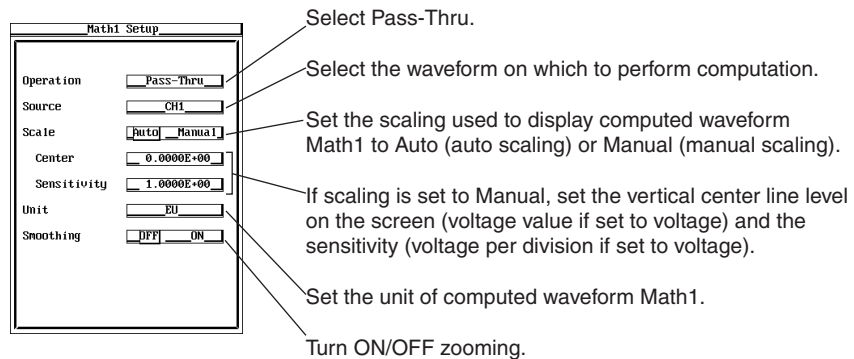

9.7 Smoothing Waveforms

Explanation

This section describes the procedures for setting the smoothing operation in normal computation mode. If the user-defined computation option is installed, you must first enter normal computation mode as described in section 9.1. For a description of the setup procedure of user-defined computation, see section 9.9.

Turning ON/OFF the Computed Waveform Display and Computed Waveform Label

See section 9.1.

Operator

Select the operator Pass-Thru as the operator for Math1 and Math2. Select the Pass-Thru operator when displaying the waveform to be computed that has been simply scaled or smoothed. For details smoothing, see section 9.2.

When using the Pass-Thru operator and smoothing is ON
The waveform to be computed is displayed after smoothing.

When using the Pass-Thru operator and smoothing is OFF
The waveform to be computed is displayed without smoothing.

Waveform to Be Computed

The waveforms on which computation can be performed are as follows:

Computation Name	Source
Math1	One channel from CH1 to CH4
Math2	One channel from CH1 to CH4 and Math1

- On the menu, CH1 to CH4 may be indicated as C1 to C4 and Math1 as M1.
- To perform computation on CH5 to CH8 on the DL7480, the optional user-defined computation function is required.

Scaling

The operation is the same as for addition, subtraction, and multiplication. See section 9.2.

Unit of Computed Waveforms

The operation is the same as for addition, subtraction, and multiplication. See section 9.2.

Smoothing

The operation is the same as for addition, subtraction, and multiplication. See section 9.2.

Effects of Linear Scaling

If linear scaling is performed on the channel to be computed, computation is performed using linearly scaled values.

Maximum Record Length That Can Be Computed

The operation is the same as for addition, subtraction, and multiplication. See section 9.2.

9.8 Shifting the Phase

Procedure

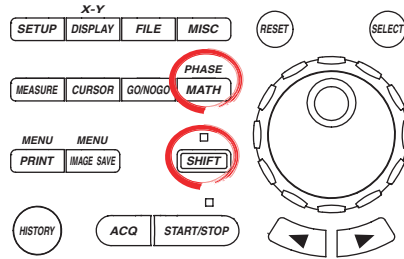

- To exit the menu during operation, press **ESC** located above the soft keys.
- In the procedural explanation below, the term *jog shuttle & SELECT* refers to the operation of selecting/setting items and entering values using the **jog shuttle** and **SELECT** and **RESET** keys. For details on this operation, see sections 4.1 or 4.2.
- For a description of the operation using a USB keyboard or a USB mouse, see section 4.3.

1. Press **SHIFT+MATH(Phase)**. The PHASE menu appears.

Turning ON/OFF the Phase-Shifted Waveforms

2. Press the **Mode** soft key to select ON or OFF.
 - When ON is selected, the phase of the displayed waveform is shifted. The amount of shift is specified in step 3 and subsequent steps.
 - When OFF is selected, the phase of the displayed waveform is not shifted.

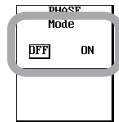

Setting the Amount of Shift

3. Press one of the **CH1 to CH8(4)** soft keys to select the channel on which the amount of shift is to be specified.

You can select up to CH4 and CH8 on the DL7440 and DL7480, respectively. CH5 to CH8 appear when you press the Next (1/2) soft key.
4. Use **jog shuttle & SELECT** to set the amount of shift.

On the DL7480, CH5 and CH8 can be selected on the next page menu.

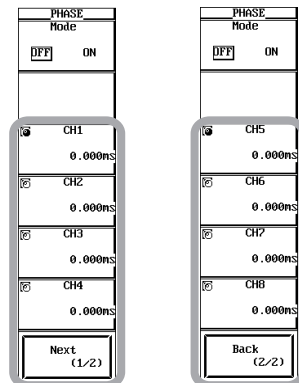

Explanation

This section explains the setup procedures for displaying the waveforms of CH1 to CH8/4 with the phase shifted.

Turning ON/OFF the Phase-Shifted Waveforms

You can turn ON/OFF the display of the phase-shifted waveforms of CH1 to CH8/4.

ON

The phase-shifted waveform is displayed

OFF

The phase-shifted waveform is not displayed

Target Channels for Phase Shifting

The target channels for phase shifting are CH1 to CH4 on the DL7440 and CH1 to CH8 on the DL7480.

Amount of Shift

You can set the amount of shift.

- The selectable range is a time value in the range of $-(\text{record length}/2)$ to $(\text{record length}/2)$.
- The resolution is $1/\text{sample rate}^*$.
 - * The sample rate varies depending on the record length or T/div setting. For details on the sample rate, see appendix 1.
- When the record length is 16 MW, the phase cannot be shifted.

Maximum Record Length That Can Be Phase Shifted

The operation is the same as for addition, subtraction, and multiplication. See section 9.2.

Note

- If the waveforms to be computed that were selected in sections 9.2 to 9.7 and 9.9 are phase shifted, the phase-shifted waveforms are used in the computation.
 - If you change T/div after setting the amount of shift, the amount of shift (time value) does not change. The displayed waveform is only expanded or reduced along the time axis.
 - The selectable range and resolution of the amount of shift vary depending on the T/div setting. The behavior when you change T/div after setting the amount of shift is indicated below. If you change T/div back to the original setting without changing the amount of shift, the original amount of shift returns.
 - When T/div is set faster (the T/div value is decreased) and the specified amount of shift exceeds the selectable range of the amount of shift at the new T/div setting, the amount of shift is set to the maximum value of the selectable range at the new T/div setting.
 - When T/div is set slower (the T/div value is increased) and the specified resolution of the amount of shift falls below the resolution of the amount of shift at the new T/div setting, the resolution is set to the resolution of the amount of shift at the new T/div setting.
-

9.9 Performing User-Defined Computation (Optional)

<For a description of this function, refer to page 2-23.>

Procedure

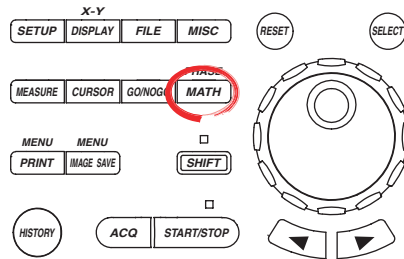

- To exit the menu during operation, press **ESC** located above the soft keys.
- In the procedural explanation below, the term *jog shuttle & SELECT* refers to the operation of selecting/setting items and entering values using the **jog shuttle** and **SELECT** and **RESET** keys. For details on this operation, see sections 4.1 or 4.2.
- For a description of the operation using a USB keyboard or a USB mouse, see section 4.3.

Note

Steps 3 to 7 describe the setup procedures for computed waveform Math1. Perform similar steps for Math2.

Entering User-Defined Computation Mode

1. Press **MATH**. The MATH menu appears.
2. Press the **Math Mode** soft key to select User. The user-defined computation menu appears.

If you select Normal, normal computation mode is enabled. For a description of the procedure, see sections 9.1 to 9.8.

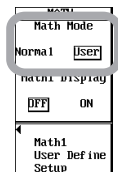

Turning ON/OFF the Computed Waveforms

3. Press the **Math1 Display** soft key to select ON or OFF.
 - If ON is selected, the Math1 waveform is displayed.
 - If OFF is selected, the Math1 waveform is not displayed.

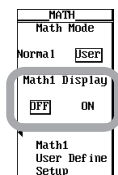

Setting the Equation, Scaling, Unit, and Label

4. Press the **Math1 User Define Setup** soft key. The Math1 User Define Setup dialog box opens.

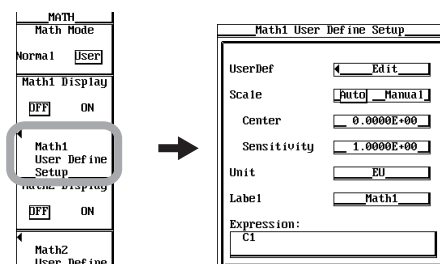

9.9 Performing User-Defined Computation (Optional)

Defining the Equation

- Use **jog shuttle & SELECT** to select UserDef. The equation definition dialog box opens.
- Enter the equation (using up to 55 characters).
The entered equation is displayed in the Expression box of the Math1 User Define Setup dialog box.

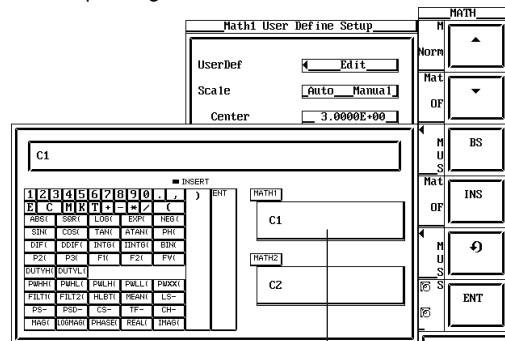

The previous equations of Math1 and Math2 are displayed.

Setting the Scaling, Unit, and Label

- Use **jog shuttle & SELECT** to set the scaling, unit, and label of computed waveform Math1.

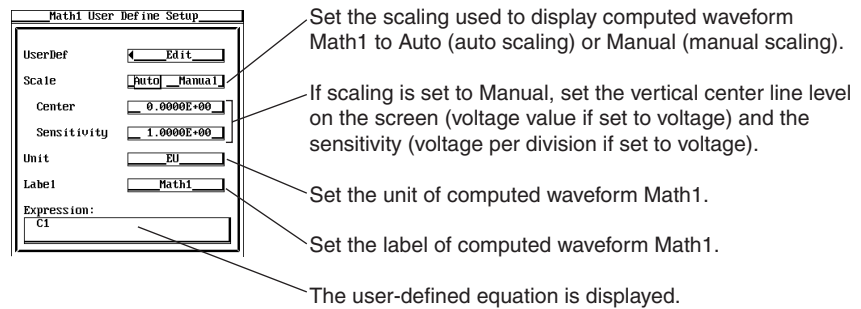

- Press **ESC**. The Math1 User Define Setup dialog box closes.

Setting the Computation Start and End Points

- Press the **Start Point/End Point** soft key to set the jog shuttle to Start Point, End Point, or both Start Point and End Point.
 - If you select Start Point, you can move the computation start point.
 - If you select End Point, you can move the computation end point.
 - If you select both Start Point and End Point, you can move the computation start point and the computation end point without changing the spacing between the two. The value of the digit being specified by Start Point changes.
- Turn the **jog shuttle** to set the computation start point and the computation end point.

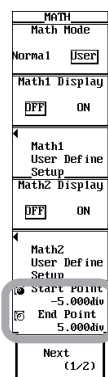

Setting the Following Items Used in the User-Defined Equation

- **FFT**
Set the number of computed points and the time window when computing LS- to CH- in the table of operators given on pages 9-24 and 9-25.
- **Digital Filter**
Set the filter type, filter frequency bandwidth, and cutoff frequency when performing computation of the FILT1 or FILT2 operators.
- **Constant**
Eight constants, K1 to K8, can be defined. You can use constants in the user-defined equation.
- **Threshold Level**
Set the threshold level for binary computation when computing BIN and FV to PWXX in the table of operators given on page 9-24.

Entering the Page 2 Menu

11. Press the **Next (1/2)** soft key. The page 2 menu appears.



Setting the Number of Points for the FFT and the Time Window

12. Press the **FFT** soft key. The FFT Setup dialog box opens.
13. Use **jog shuttle & SELECT** to set the number of computed points and the time window.
14. Press **ESC**. The FFT Setup dialog box closes.

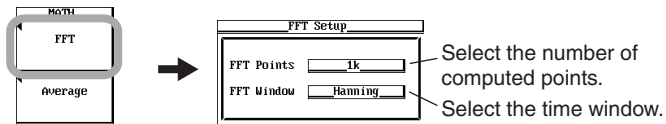

Setting the Filter Operator, Filter Type, Filter Frequency Bandwidth, and Cutoff Frequency of the Digital Filter

15. Press the **Filter** soft key. The Filter dialog box opens.
16. Use the **jog shuttle and SELECT** to set the filter operator, filter type, filter frequency bandwidth, and cutoff frequency.
17. Press **ESC**. The Filter dialog box closes.

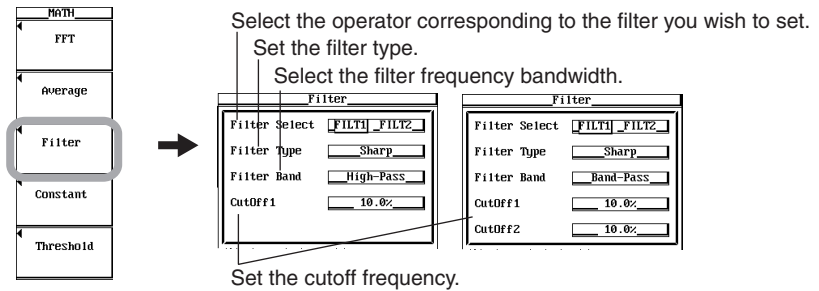

9.9 Performing User-Defined Computation (Optional)

Setting Constants K1 to K8

18. Press the **Constant** soft key. A Constant dialog box opens.
19. Use **jog shuttle & SELECT** to set constants K1 to K8.
20. Press **ESC**. The Constant dialog box closes.

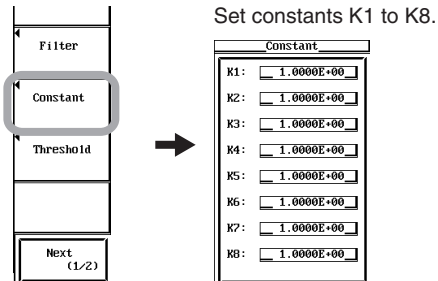

Setting the Threshold Level for Binary Computation

21. Press the **Threshold** soft key. The Threshold dialog box opens.
22. Use the **jog shuttle and SELECT** to set the waveform on which to set the threshold level for binary computation and the threshold level.
23. Press **ESC**. The Threshold dialog box closes.

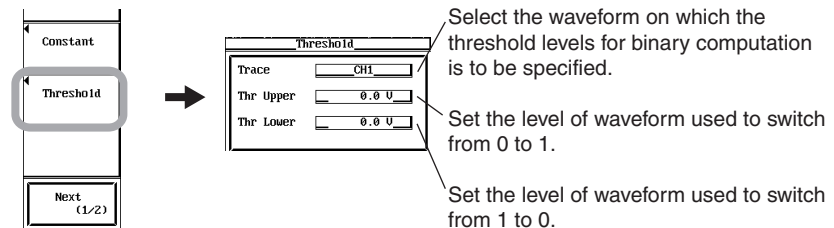

Performing Averaging and Peak Computation of Computed Waveforms (Computed Results)

24. Press the **Average** soft key. The Average dialog box appears.
25. Use **jog shuttle & SELECT** to select averaging or peak computation.
 - If you select averaging (linear averaging, exponential averaging, or cycle averaging), enter settings corresponding to the averaging type according to the following steps.
 - If you select peak computation or OFF (not perform averaging or peak computation), the procedure ends here.

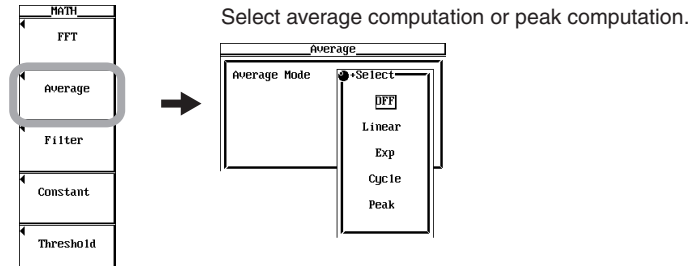

When Linear Averaging Is Selected (Setting the Domain to Be Averaged and the Average Count (the Number of Acquisitions of the Computed Waveform to Be Averaged))

26. Use **jog shuttle & SELECT** to select the domain to be averaged.
27. Use **jog shuttle & SELECT** to set the average count (the number of acquisitions of the computed waveform to be averaged).

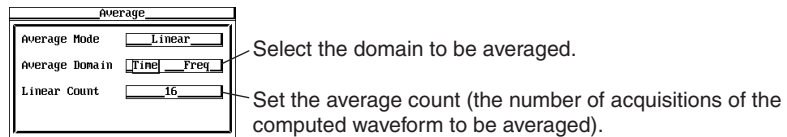

When Exponential Averaging Is Selected (Setting the Domain to Be Averaged and the Attenuation Constant)

26. Use **jog shuttle & SELECT** to select the domain to be averaged.
27. Use **jog shuttle & SELECT** to set the attenuation constant.

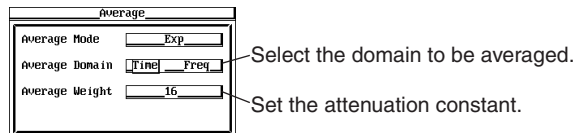

When Cycle Averaging Is Selected (Setting the Number of Data Points of 1 Cycle That Is to Be Averaged)

26. Use **jog shuttle & SELECT** to set the number of data points of 1 cycle that is to be averaged. Proceed to step 28.

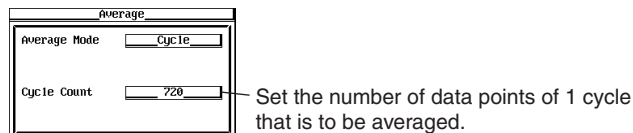

Closing the Average Dialog Box

28. Press **ESC**. The Average dialog box closes.

9.9 Performing User-Defined Computation (Optional)

Explanation

This section describes the setup procedures in user-defined computation (option) mode. For the setup procedure in normal computation mode, see sections 9.1 to 9.8.

Note

When user-defined computation is in progress, * is displayed in the upper left corner of the screen.

Turning ON/OFF the Computed Waveform Display

The display of the computed waveforms Math1 and Math2 can be turned ON/OFF individually.

ON

Computed waveforms are displayed.

OFF

Computed waveforms are not displayed.

Operator

You can define equations by combining the following operators for Math1 and Math2.

Operators and Examples	Computation	Computation
+, -, *, /	C1+C2	Four arithmetical operations of the two specified waveforms
ABS	ABS(M1)	The absolute value of the specified waveform
SQRT	SQRT(C2)	The square root of the specified waveform
LOG	LOG(C1)	The logarithm of the specified waveform
EXP	EXP(C1)	The exponent of the specified waveform
NEG	NEG(C1)	The inversion of the specified waveform around level 0.
SIN	SIN(T)	The sine of the specified waveform
COS	COS(C1)	The cosine of the specified waveform
TAN	TAN(C1)	The tangent of the specified waveform
ATAN	ATAN(C1,C2)	The arc tangent of the two specified waveforms (a value within $\pm\pi$)
PH	PH(C1,C2)	The phase difference between the two specified waveforms
DIF	DIF(C1)	The differentiation of the specified waveform
DDIF	DDIF(C1)	The secondary differentiation of the specified waveform
INTG	INTG(C1)	The integration of the specified waveform
IINTEG	IINTEG(C1)	The secondary integration of the specified waveform
BIN	BIN(C1)	The binary conversion of the specified waveform
P2	P2(C1)	The square of the specified waveform
P3	P3(C1)	The cube of the specified waveform
F1	F1(C1,C2)	$\sqrt{ C1^2 + C2^2 }$ of the specified waveform
F2	F2(C1,C2)	$\sqrt{ C1^2 - C2^2 }$ of the specified waveform
FV	FV(C1)	The inverse of the PWHH of the pulse width
PWHH	PWHH(M1)	Pulse width computation from the rising edge to the next rising edge
PWHL	PWHL(C2)	Pulse width computation from the rising edge to the next falling edge
PWLH	PWLH(C1)	Pulse width computation from the falling edge to the next falling edge
PWLL	PWLL(C1)	Pulse width computation from the falling edge to the next rising edge
PWXX	PWXX(C2)	Pulse width computation from the rising or falling edge to the next rising or falling edge
DUTYH	DUTYH(C1)	Positive (high) duty cycle within each cycle of the specified waveform
DUTHL	DUTYL(C1)	Negative (low) duty cycle within each cycle of the specified waveform
FILT1	FILT1(C1)	Apply a filter to the specified waveform
FILT2	FILT2(C1)	Apply a filter to the specified waveform
HLBT	HLBT(C1)	The Hilbert's transform of the specified waveform
MEAN	MEAN(C1)	The moving average of the 10 th order of the specified waveform
LS-		
	LS-MAG(C1)	The amplitude of the specified waveform's linear spectrum
	LS-LOGMAG(C1)	The logarithmic amplitude of the specified waveform's linear spectrum
	LS-PHASE(C1)	The phase of the specified waveform's linear spectrum
	LS-REAL(C1)	The real part of the specified waveform's linear spectrum
	LS-IMAG(C1)	The imaginary part of the specified waveform's linear spectrum

Operators and Examples	Computation
PS-	
PS-MAG(C1)	The amplitude of the specified waveform's power spectrum
PS-LOGMAG(C1)	The logarithmic amplitude of the specified waveform's power spectrum
PSD-	
PSD-MAG(C1)	The amplitude of the specified waveform's power spectrum density
PSD-LOGMAG(C1)	The logarithmic amplitude of the specified waveform's power spectrum density
CS-	
CS-MAG(C1,C2)	The amplitude of the two specified waveforms' cross spectrum
CS-LOGMAG(C1,C2)	The logarithmic amplitude of the two specified waveforms' cross spectrum
CS-PHASE(C1,C2)	The phase of the two specified waveforms' cross spectrum
CS-REAL(C1,C2)	The real part of the two specified waveforms' cross spectrum
CS-IMAG(C1,C2)	The imaginary part of the two specified waveforms' cross spectrum
TF-	
TF-MAG(C1,C2)	The amplitude of the two specified waveforms' transfer function
TF-LOGMAG(C1,C2)	The logarithmic amplitude of the two specified waveforms' transfer function
TF-PHASE(C1,C2)	The phase of the two specified waveforms' transfer function
TF-REAL(C1,C2)	The real part of the two specified waveforms' transfer function
TF-IMAG(C1,C2)	The imaginary part of the two specified waveforms' transfer function
CH-	
CH-MAG(C1,C2)	The amplitude of the two specified waveforms' coherence function

Waveform to Be Computed and Variables

The waveform to be computed and variables of Math1 and Math2 are as follows:

Waveform to Be Computed

Computation Name	Waveform to Be Computed and Variables
Math1	DL7440: One channel from CH1 to CH4 DL7480: One channel from CH1 to CH8
Math2	DL7440: One channel from CH1 to CH4 and Math1 DL7480: One channel from CH1 to CH8 and Math1

- In the equation set CH1 to CH8 as C1 to C8 and Math1 as M1.
- On the menu, CH1 to CH4 may be indicated as C1 to C4 and Math1 as M1.

Variable T

This is the integrated value of the number of data points on the time axis. It is displayed as a rising line on the screen. Using the variable T that is displayed in the equation definition dialog box, you can define the integrated value of the number of data points that increase with time in the equation.

Exponent of 10

You can set the exponent of 10 by using the "E" displayed in the equation definition dialog box. For example, 1×10^3 can be entered as 1E3.

Note

When the waveform to be computed is phase shifted (see section 9.8), the phase-shifted waveform is used in the computation.

9.9 Performing User-Defined Computation (Optional)

Combinations of Computing Equations That Are Not Allowed

Math2 cannot be placed in the equation of Math1.

Example: $\text{Math1} = \text{M2} + \text{C3}$

Computation containing only constants (K1 to K8) is not allowed.

Example: $\text{Math1} = \text{K1} + \text{K8}$

Only up to two operators can be used in an equation for FILT1 and FILT2.

Example: $\text{FILT1}(\text{C1}) + \text{FILT1}(\text{C2}) + \text{FILT1}(\text{C3})$

Computation cannot be performed on the result of the FFT.

Example: $\text{PS-MAG}(\text{C1}) + \text{C2}$

Computations cannot be performed on the pulse width computation.

Example: $\text{PWHH}(\text{C1}) + \text{C2}$

Only one waveform to be computed can be used in an equation when performing FFT, binary computation, and pulse width computation.

Example: $\text{PS-MAG}(\text{C1} + \text{C2})$, $\text{BIN}(\text{C1} - \text{C2})$, $\text{PWHH}(\text{C1} * \text{C1})$

Note

If you wish to perform FFT, binary computation, or pulse width computation on the computed result (example: $\text{C1} + \text{C2}$), use two equations (example: first set $\text{Math1} = \text{C1} + \text{C2}$, and then set $\text{Math2} = \text{PS-MAG}(\text{M1})$).

Scaling

The operation is the same as for addition, subtraction, and multiplication of normal computation. See section 9.2.

Unit of Computed Waveforms

The operation is the same as for addition, subtraction, and multiplication of normal computation. See section 9.2.

Computed Waveform Labels

The operation is the same as for normal computation. See section 9.1.

Computation Start Point and Computation End Point (Computation Range)

You can set the computation range (applies to both Math1 and Math2). The selectable range is ± 5 divisions, and the resolution is 10 divisions \div the display record length. For a description of the display record length, see appendix 1.

Items Used in the User-Defined Equation

You can set the computation condition of the following items used in the user-defined equation (applies to both Math1 and Math2).

FFT

- You can set the number of computed points and the time window when computing LS- to CH- in the table of operators given on pages 9-24 and 9-25. For the selection items of the number of computed points and the time window, see section 9.6.
- For computation details, see appendix 4.

Digital Filter

- The table below shows the selectable filter types, filter frequency bandwidths, and cutoff frequency types.

Filter Type	Frequency Bandwidth Type	Cutoff Frequency Setting
Gauss	LowPass	Set the high cutoff frequency in CutOff1.
Sharp	LowPass	Set the high cutoff frequency in CutOff1.
	BandPass	Set the low and high cutoff frequencies in CutOff1 or CutOff2.
	HighPass	Set the low cutoff frequency in CutOff1.
IIR (Butterworth)	LowPass	Set the high cutoff frequency in CutOff1.
	BandPass	Set the low and high cutoff frequencies in CutOff1 or CutOff2.
	HighPass	Set the low cutoff frequency in CutOff1.

* The cutoff frequencies can be set in the range of 2.0% to 30.0% (0.2% steps) of the sample rate.

- For computation details, see appendix 4.

Constant

Eight constants, K1 to K8, can be defined. You can use the constants in the user-defined equation. The selectable range is $-9.9999E+30$ to $9.9999E+30$.

Threshold Level for Binary Computation

You can set the threshold level for binary computation when computing BIN and FV to PWXX in the table of operators given on page 9-24. The operation is the same as for the binary computation of normal computation. See section 9.3.

Averaging and Peak Computation of Computed Waveforms (Computed Results)

Averaging and peak computation can be performed on the computed data (applies to both Math1 and Math2). Three types of averaging are available: simple, exponential, and cycle.

Simple Averaging

The result obtained by simply summing the values for the average count and dividing by the average count is displayed as a waveform. You can set the following two items.

Item	Selections or Selectable Range
Average Domain (Domain in which averaging is performed)	Time (time domain) Freq (frequency domain)
Linear Count (Average count, the number of acquisitions of the computed waveform to be averaged)	2 to 128, 2^n steps, where n is a positive integer.

Exponential Averaging

The average is determined by attenuating the effects of past data according to the specified attenuation constant. The resultant waveform is displayed. You can set the following two items.

Item	Selections or Selectable Range
Average Domain (Domain in which averaging is performed)	Time (time domain) Freq (frequency domain)
Average Weight (Attenuation constant)	2 to 256, 2^n steps, where n is a positive integer.

9.9 Performing User-Defined Computation (Optional)

Cycle Averaging

- Divides one period of computed data into the specified number of data points (Cycle Count). This is done across multiple periods of data from the start to the end position of the computation. Then, the average of the data points at the same position across multiple periods is determined. The resulting waveform is displayed. You can set the following items.

Item	Selectable Range
Cycle Count (The number of data points of 1 cycle that is to be averaged)	10 to 1800, positive integer.

- * The data from the computation start position to the end position is averaged. However, the remaining data that is not divisible by the Cycle Count are ignored.

Example

When the record length is 10 k, the Cycle Count is 720, the start point of computation is -5.000 divisions, and the end point is +5.000 divisions

$10k/720 = 13.88...$ 13 cycles will be averaged.

$13 \times 720 = 9360$ Data between the start point to the 9360th point will be cycle averaged.

- Cycle averaging cannot be performed on the waveform obtained through the FFT.

Peak Computation

Determines the maximum value at each point of the computed data and displays the waveform. For each computation, the new computed value is compared with the past computed value and the larger value is kept.

Note

- Normally, the DL7400 determines the vertical waveform display range by performing auto scaling on the first computed waveform. If the amplitude of the computed waveform varies greatly such as in the coherence function, use manual scaling.
 - If an averaged waveform is auto scaled and you change the scaling to manual when measurement is stopped, the setting does not take effect. The setting takes effect the next time measurement is started.
 - When averaging is selected (excluding cycle averaging), computation is not performed again when measurement is stopped. For example, even if the equation is changed, the computed waveform does not change. The new setting is enabled the next time measurement is started. However, if you change the number of data points of cycle averaging, recalculation is performed even when measurement is stopped.
 - Averaging cannot be performed on the pulse width waveform.
 - If you change the computation conditions while averaging is in progress, the computed data up to that point is cleared. Then, averaging starts.
 - Averaging and peak computation cannot be performed when the trigger mode is set to SINGLE(N) mode.
-

Effects of Linear Scaling

If linear scaling is performed on the channel to be computed, computation is performed using linearly scaled values.

Maximum Record Length That Can Be Computed

The operation is the same as for addition, subtraction, and multiplication. See section 9.2. However, the maximum number of computed points is 2 MW. The computation range is set by specifying the computation start point and the computation end point (see page 9-26).

10.1 Displaying History Waveforms

<For a description of this function, refer to page 2-17.>

Procedure

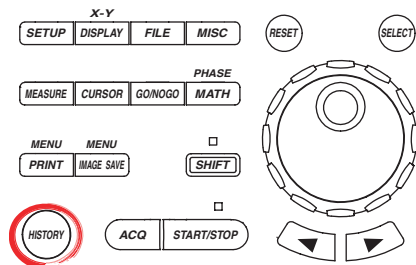

- To exit the menu during operation, press **ESC** located above the soft keys.
- In the procedural explanation below, the term *jog shuttle & SELECT* refers to the operation of selecting/setting items and entering values using the **jog shuttle** and **SELECT** and **RESET** keys. For details on this operation, see sections 4.1 or 4.2.
- For a description of the operation using a USB keyboard or a USB mouse, see section 4.3.

1. Press **HISTORY**. The HISTORY menu appears.

Displaying History Waveforms One by One

2. Press the **Select Record** soft key.
3. Turn the **jog shuttle** to select the number of the record to be displayed.
You can select the record number in the range of Start Record to End Record shown on the menu.
4. Press the **Display Mode** soft key to select One. Only the waveform of the record number indicated in Select Record on the menu is displayed.

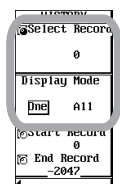

Accumulating (Collectively Displaying) the History Waveforms

Setting the Range to be Accumulated

2. Press the **Start Record/End Record** soft key to set the jog shuttle control to Start Record or End Record.
 - If you select Start Record, you can select the record number for starting the accumulation.
 - If you select End Record, you can select the record number for ending the accumulation.
3. Turn the **jog shuttle** to set the record number at which accumulation is to be started or ended.
4. Press the **Display Mode** soft key to select All. The waveforms in the range between Start Record and End Record shown on the menu are accumulated on the screen.

The waveform of the record number indicated in Select Record on the menu is highlighted.



10.1 Displaying History Waveforms

Selecting the Highlighted Waveform

5. Press the **Select Record** soft key.
6. Turn the **jog shuttle** to select the number of the record to be highlighted. The waveform of the selected record number is highlighted.



Selecting the Waveforms to be Displayed on the History Map

Displaying the History Map

2. Press the **Start Record/End Record** soft key to set the jog shuttle control to Start Record or End Record.
 - If you select Start Record, you can select the first record number displayed on the history map.
 - If you select End Record, you can select the last record number displayed on the history map.
3. Turn the **jog shuttle** to set the first or last record number displayed on the history map.
4. Press the **Show Map** soft key. The record numbers and time stamps (time when acquisition was completed) of the waveforms in the range of Start Record to End Record on the menu are listed.

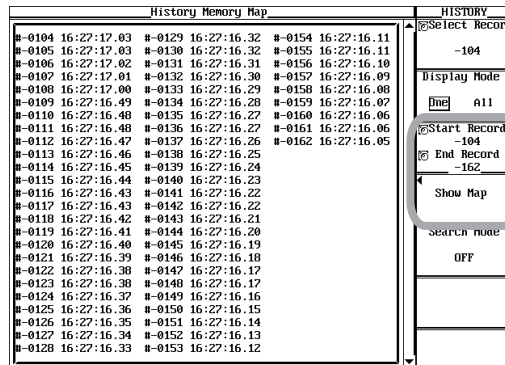

Selecting the Waveforms to Be Displayed

5. Use **jog shuttle & SELECT** to select the waveform to be displayed. The selected waveform is displayed, and the record number of the selected waveform is indicated in Select Record on the menu.
 - If the Display Mode is set to One, only the selected waveform is displayed.
 - If the Display Mode is set to All, the selected waveform is highlighted.

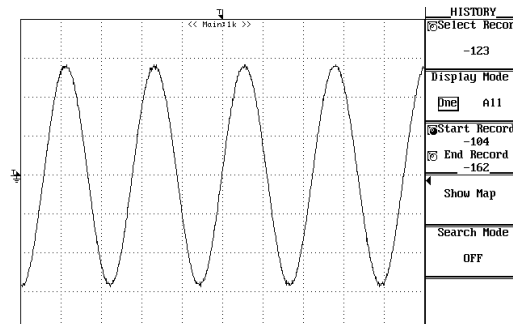

Explanation

This section describes the procedures for displaying history waveforms. The waveforms that have been sequentially stored can also be displayed in the same fashion.

Number of History Waveforms

The table below shows the number of history waveforms that can be stored and held in the acquisition memory according to the maximum record length and specified record length of each model. If a waveform is acquired (a trigger is activated) exceeding this number, the oldest waveform is cleared.

Specified Record Length	Record Length 16 MW Memory Model (Models 701460 and 701480)	Record Length 4 MW Memory Model (Models 701450 and 701470)
1 kW	1 to 2048 (4096)	1 to 2048 (4096)
10 kW	1 to 256 (512)	1 to 256 (512)
50 kW	1 to 64 (128)	1 to 64 (128)
100 kW	1 to 32 (64)	1 to 32 (64)
250 kW	1 to 16 (32)	1 to 16 (32)
500 kW	1 to 8 (16)	1 to 8 (16)
1 MW	1 to 4 (8)	1 to 4 (8)
2 MW	1 to 2 (4)	1 to 2 (4)
4 MW	1 (2)	–(2)
8 MW	1 (1)	–
16 MW	–(1)	–

- If the trigger count is 1, only the displayed waveform is held in the acquisition memory; past waveforms are not held.
- Values inside the parentheses are the number of waveforms when interleave mode is ON.
- When box average is performed, acquisition is possible up to 4 MW (8 MW when interleave mode is ON) on 16 MW memory models and up to 1 MW (2 MW when interleave mode is ON) on 4 MW memory models.

Selectable Range of History Waveforms

- History waveforms have record numbers attached to them.
- The newest (current) waveform is 0, the waveform previous to that is –1, and so on.
- To select the waveform to be displayed, select the record number in the range of 0 to –(the number of history waveforms – 1). The number of history waveforms varies depending on the specified record length as indicated in the table above.
- The default value is 0.

Display Mode

You can select the display mode.

One

Displays only the waveform of the record number selected by Select Record from the range specified by Start Record and End Record.

All

Displays accumulated all the waveforms in the range specified by Start Record and End Record. The waveform selected by Select Record is highlighted (displayed brightly).

History Map

- The record numbers and time stamps (time when acquisition was completed displayed in hour:minute:second.1/100 second format) of the history waveforms are listed.
- The information of 75 waveforms is displayed on 1 screen.
- You can scroll and select the data to be displayed using the jog shuttle and display the selected waveform.

Note

Notes When Using the History Memory Function

- The history memory function cannot be used if the acquisition mode is Average.
- The history memory function cannot be used when in repetitive sampling mode.
- If waveform acquisition is aborted, only the waveforms that have been acquired completely can be displayed.
- The history memory function cannot be used in roll mode. The display format is automatically set to roll mode depending on the time axis and record length settings (see appendix 1).
- If you stop the waveform acquisition and restart without changing the waveform acquisition conditions, the waveform acquisition count of the history waveforms is not reset, and the remaining number of acquisitions are stored and held as history waveforms. The history waveforms that have been held up to the point when the acquisition was stopped are retained.
- If you change the waveform acquisition conditions, history waveforms up to that point are cleared when you restart acquisition using the new settings.
- If you press the CLEAR TRACE key while waveform acquisition is in progress or if you stop waveform acquisition, press the CLEAR TRACE key, and restart acquisition, the history waveforms are cleared.

Notes When Displaying History Waveforms

- When the history memory menu is displayed, waveform acquisition stops. History waveforms cannot be displayed while waveform acquisition is in progress.
 - You can start waveform acquisition even when the history memory menu is displayed. However, while acquisition is in progress, you cannot change the settings of the history memory function such as Select Record.
 - Settings are restricted by the following condition: $\text{End Record} \leq \text{Select Record} \leq \text{Start Record}$.
 - If waveform data is loaded from a file stored on the specified storage medium, the history waveforms up to that point are cleared. The loaded waveform data is always recalled to the record number 0 position of the history memory. If a file containing multiple waveforms is loaded, the newest waveform is recalled in the record number 0 position, the next newest waveform in -1, and so on.
 - Computation and automated measurement of waveform parameters are performed on the waveform of the record number specified by Select Record. Computation and analysis of old waveforms is possible until the history waveforms are changed by restarting acquisition.
 - Past waveforms are held in roll mode. Only 1 waveform when acquisition is stopped is stored in the record number 0 position.
 - It may take some time to display all the history waveforms, if the number of waveforms to be displayed is large. To abort, set the display mode to One.
 - Turning OFF the power clears the history waveforms.
-

10.2 Searching the History Waveforms Using Zones (History Search)

<For a description of this function, refer to page 2-25.>

Procedure

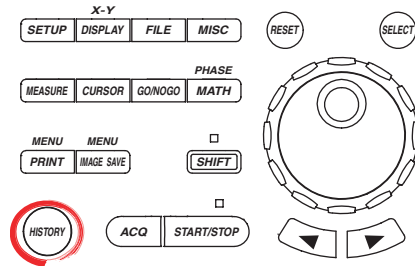

- To exit the menu during operation, press **ESC** located above the soft keys.
- For a description of the operation using a USB keyboard or a USB mouse, see section 4.3.

1. Press **HISTORY**. The HISTORY menu appears.
2. Press the **Search Mode** soft key. The Search Mode menu appears.
3. Press the **Zone** soft key.

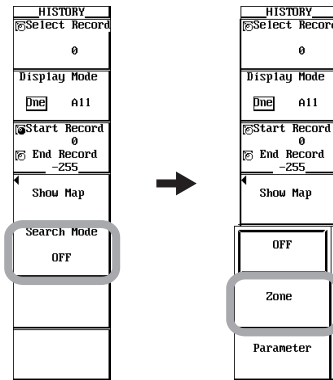

Setting the Search Zone and Search Conditions

4. Press the **Search Setup** soft key. The Search Setup menu appears.



10.2 Searching the History Waveforms Using Zones (History Search)

Selecting the Zone for Registering Search Conditions

5. Press the **Select Zone** soft key. The Select Zone menu appears.
6. Press any of the **Zone1** to **Zone4** soft keys to select the parameter in which search conditions are to be registered.

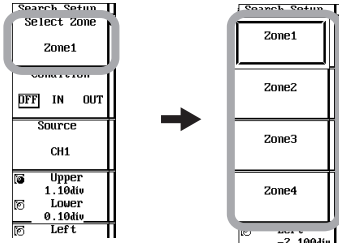

Selecting the Condition of the Waveform to Be Searched in the Search Zone

7. Press the **Condition** soft key to select OFF, IN, or OUT.
If you select IN or OUT and select a displayed waveform in step 9, the search zone (rectangular frame) is displayed.

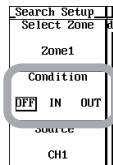

Selecting the Search Target Waveform

8. Press the **Source** soft key. The Source menu appears.
9. Press the **CH1** to **CH8/4**, **Math1**, or **Math2** soft key to select the search target waveform.
 - On the DL7440, select CH1 to CH4, Math1, or Math2.
 - On the DL7480, select CH1 to CH8, Math1, or Math2. CH7, CH8, Math1, and Math2 appear when you press the To Page 2 soft key.
 - If you select a displayed waveform as a search target and select IN or OUT in step 7, the search zone (rectangular frame) is displayed.

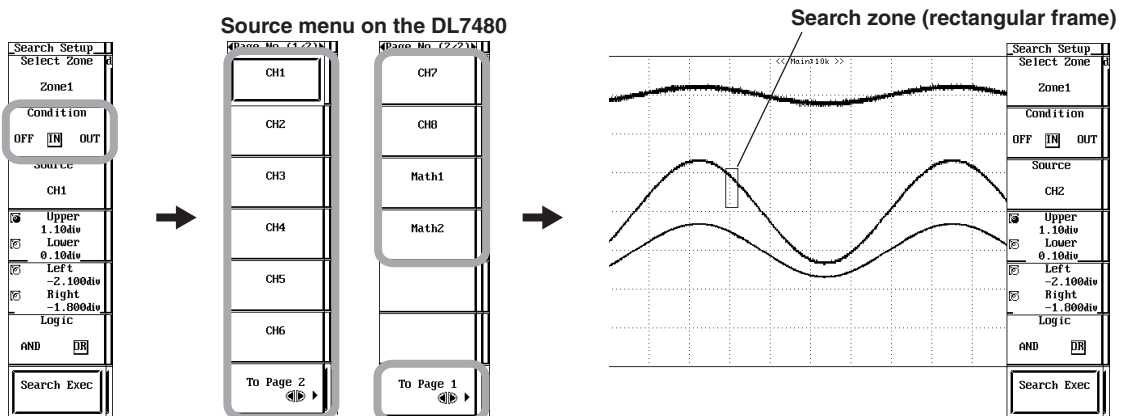

Setting the Range of the Search Zone

10. Press the **Upper/Lower** soft key to set the jog shuttle control to Upper, Lower, or both Upper and Lower.
 - If you select Upper, you can move the top edge of the zone.
 - If you select Lower, you can move the bottom edge of the zone.
 - If you select both Upper and Lower, you can move the position of the zone vertically without changing the spacing between the top and bottom edges of the zone. The value of the digit being specified by Upper changes.
11. Turn the **jog shuttle** to set the top and bottom edges of the zone.
12. Press the **Left/Right** soft key to set the jog shuttle control to Left, Right, or both Left and Right.
 - If you select Left, you can move the left edge of the zone.
 - If you select Right, you can move the right edge of the zone.
 - If you select both Left and Right, you can move the position of the zone horizontally without changing the spacing between the left and right edges of the zone. The value of the digit being specified by Left changes.
13. Turn the **jog shuttle** to set the left and right edges of the zone.
14. Repeat steps 5 to 13 to set Zone1 to Zone4.

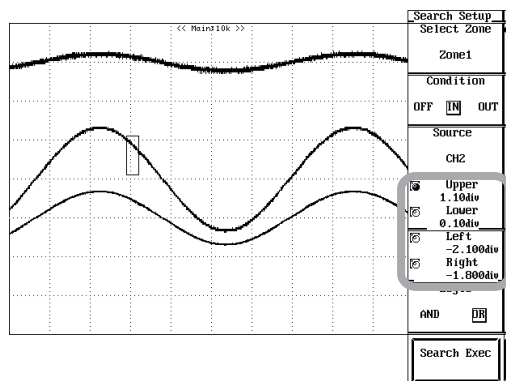

Selecting the Search Logic

15. Press the **Logic** soft key to select AND or OR.



Executing/Aborting the Search

16. Press the **Search Exec** soft key. The search is executed, and the ,words Search Exec change to Search Abort.
To abort the search, press the **Search abort** soft key. The search is aborted, and the words Search Abort change to Search Exec.

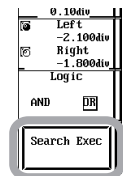

10.2 Searching the History Waveforms Using Zones (History Search)

Displaying the Searched Waveforms

17. Press the **ESC** to return to the HISTORY menu.
18. Display the waveform according to the procedure given in section 10.1.
The history map lists the record numbers and time stamps of the searched waveforms.

Resetting the Search Results

19. Set the Search Mode to OFF in the HISTORY menu, or turn OFF Zone1 to Zone4 and execute the search. The search result is reset.

Explanation

This section explains the setup procedures for searching history waveforms that pass or not pass a specified search zone.

Search Zone

You can register up to 4 search zones, zone1 to zone4. For each search zone, you can set the following search conditions. You can also set whether to use AND or OR logic of the search conditions of the four search zones to perform the search (see "Search Logic" described later).

- Condition of the search target waveform in the search zone
- Search target waveform
- Search zone range

Condition of the Search Target Waveform in the Search Zone

You can select the condition of the target waveform to be searched in the search zone.

OFF	Not searched.
IN	Searches waveforms that pass through the specified search zone. Also searches cases when the waveforms pass through the boundary lines.
OUT	Searches waveforms that do not pass through the specified search zone.

Search Target Waveform

You can select the search target waveform. If a waveform that meets the search condition is found, other history waveforms at the same time as the found waveform are also displayed.

DL7440	You can select the target waveform from CH1 to CH4, Math1, and Math2.
DL7480	You can select the target waveform from CH1 to CH8, Math1, and Math2.

Range of the Search Zone (Rectangular Frame)

You can set the top, bottom, left, and right edges of the search zone.

Top and Bottom Edges	The selectable range is ± 4 divisions, and the resolution is 0.01 divisions. The top edge (Upper) must be greater than or equal to the bottom edge (Lower)
Left and Right Edges	The selectable range is ± 5 divisions, and the resolution is 10 divisions+the display record length. The right edge must be greater than or equal to the left edge. For a description of the display record length, see appendix 1.

Search Logic

You can select the AND logic or OR logic of the search conditions of the four search zones in performing the search.

AND

Searches for waveforms that meet all search conditions of Zone1 to Zone4.

OR

Searches for waveforms that meet any one of the search conditions of Zone1 to Zone4.

Search Range

You can search the history waveform in the range specified by Start Record and End Record of the History menu (see section 10.1)

Search Method

Search is performed in order from the newest history waveform.

History Map after the Search (Search Result)

The record numbers and time stamps of the waveforms that are found can be listed on the history map. If you set the Search Mode to OFF in the HISTORY menu, or turn OFF Zone1 to Zone4 and execute the search, the search result is reset.

10.3 Searching History Waveforms Using Waveform Parameters (History Search)

<For a description of this function, refer to page 2-25.>

Procedure

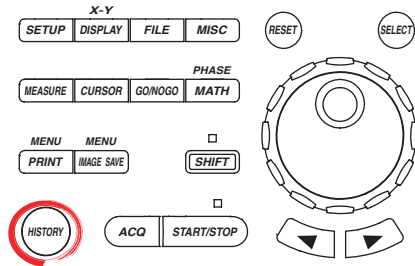

- To exit the menu during operation, press **ESC** located above the soft keys.
- For a description of the operation using a USB keyboard or a USB mouse, see section 4.3.

1. Press **HISTORY**. The HISTORY menu appears.
2. Press the **Search Mode** soft key. The Search Mode menu appears.
3. Press the **Parameter** soft key.

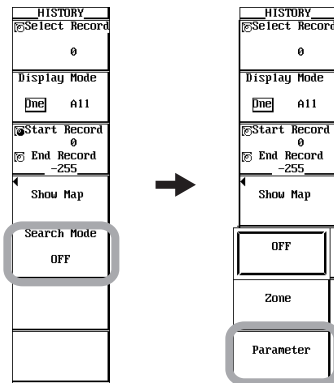

Setting the Search Parameter and Search Conditions

4. Press the **Search Setup** soft key. The Search Setup menu appears.

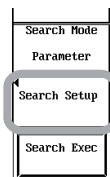

10.3 Searching History Waveforms Using Waveform Parameters (History Search)

Selecting the Parameter for Registering Search Conditions

5. Press the **Select Param** soft key. The Select Param menu appears.
6. Press any of the **Param1** to **Param4** soft keys to select the measurement parameter in which search conditions are to be registered.

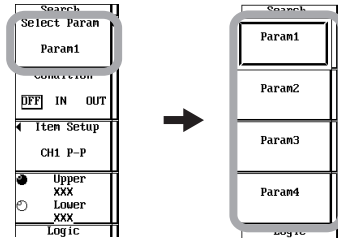

Selecting the Condition of the Waveform to Be Searched for the Search Parameter

7. Press the **Condition** soft key to select OFF, IN, or OUT.

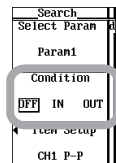

Selecting the Search Target Waveform and Search Measurement Parameter

8. Press the **Item Setup** soft key. The Item Setup dialog box opens.
9. Press the **CH1** to **CH8/4**, **Math1**, or **Math2** soft key to select the search target waveform.
 - On the DL7440, select CH1 to CH4, Math1, or Math2.
 - On the DL7480, select CH1 to CH8, Math1, or Math2. CH7, CH8, Math1, and Math2 appear when you press the To Page 2 soft key.
10. Turn the **jog shuttle** to select the measurement parameter to be used as a search condition.
11. Press **SELECT**. The mark to the left of the measurement parameter is highlighted.

The measurement item whose mark to the left of the item is highlighted is the measurement item used as a search condition. You can set one measurement parameter to one search parameter.
12. Press **ESC**. The Item Setup dialog box closes.

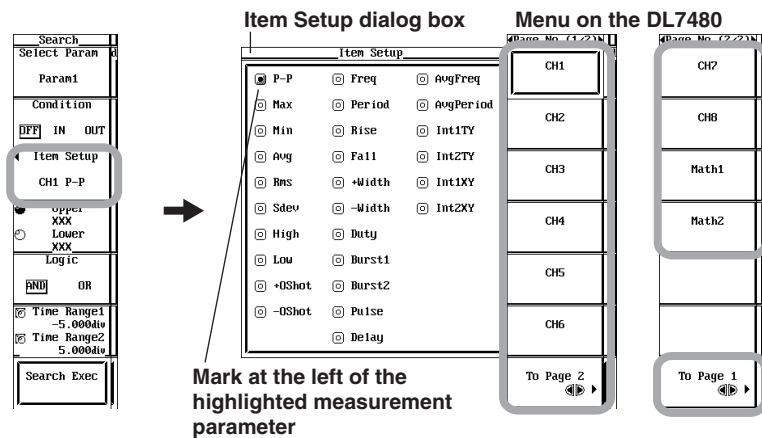

10.3 Searching History Waveforms Using Waveform Parameters (History Search)

Setting the Determination Range of the Measured Value of the Search Measurement Parameter

- Press the **Upper/Lower** soft key to set the jog shuttle control to Upper or Lower.
 - If you select Upper, you can move the upper limit of the determination range.
 - If you select Lower, you can move the lower limit of the determination range.
- Turn the **jog shuttle** to set the upper and lower limits of the determination range.
- Repeat steps 5 to 14 to set Param1 to Param4.

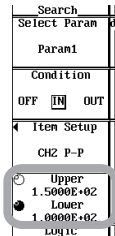

Selecting the Search Logic

- Press the **Logic** soft key to select AND or OR.

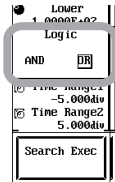

Setting the Search Range

- Press the **Time Range1/Time Range2** soft key to set the jog shuttle control to Time Range1, Time Range2, or both Time Range1 and Time Range2.
 - If you select Time Range1, you can set the left end of the search range.
 - If you select Time Range2, you can set the right end of the search range.
 - If you select both Time Range1 and Time Range2, you can move the search range without changing the spacing between the two. The value of the digit being specified by Time Range1 changes.
- Turn the **jog shuttle** to set the search range.

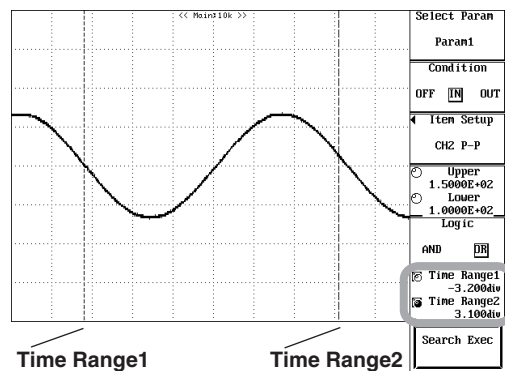

Executing/Aborting the Search

19. Press the **Search Exec** soft key. The search is executed, and the words Search Exec change to Search Abort. To abort the search, press the **Search abort** soft key. The search is aborted, and the words Search Abort change to Search Exec.

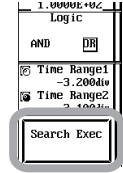

Displaying the Searched Waveforms

20. Press the **ESC** to return to the HISTORY menu.
21. Display the waveform according to the procedure given in section 10.1.
The history map lists the record numbers and time stamps of the searched waveforms.

Resetting the Search Results

22. Set the Search Mode to OFF in the **HISTORY** menu, or turn OFF Param1 to Param4 and execute the search. The search result is reset.

Explanation

This section explains the setup procedures for searching history waveforms that meet or do not meet the specified search parameter conditions.

Search Parameter

You can register up to four search parameters, Param1 to Param4. For each search parameter, you can set the search conditions below. You can also set whether to use AND or OR logic of the search conditions of the four search parameters to perform the search (see “Search Logic” described later).

- Condition of the search target waveform with respect to the search parameter
- Search target waveform and search measurement parameter
- Determination range of the measured value of the measurement search parameter
- Search range

Condition of the Search Target Waveform with Respect to the Search Parameter

You can select from the following.

OFF	Not searched.
IN	Searches for waveforms whose measured value of the search and measurement parameter is within the determination range of the specified search parameter. Search is also made on boundary values.
OUT	Searches for waveforms whose measured value of the search and measurement parameter is outside the determination range of the specified search parameter.

10.3 Searching History Waveforms Using Waveform Parameters (History Search)

Search Target Waveform and Search Measurement Parameter

You can select the target waveform and the measurement parameter to be used as a search condition. If a waveform that meets the search condition is found, other history waveforms at the same time as the found waveform are also displayed.

Search Target Waveform

DL7440

You can select the target waveform from CH1 to CH4, Math1, and Math2.

DL7480

You can select the target waveform from CH1 to CH8, Math1, and Math2.

Search Measurement Parameters

Same as the measurement parameters of the automated measurement of waveform parameters. See section 10.6.

Determination Range of the Measured Value of the Search Measurement Parameter

You can set the upper and lower limits of the determination range. The selectable range is $-9.9999E+30$ to $9.9999E+30$. The upper limit must be greater than or equal to the lower limit.

Search Logic

You can select the AND logic or OR logic of the search conditions of the four search parameters in performing the search.

AND

Searches for waveforms that meet all search conditions from Param1 to Param4.

OR

Searches for waveforms that meet any one of the search conditions from Param1 to Param4.

Search Range

The selectable range is ± 5 divisions, and the resolution is 10 divisions+the display record length. The right end of the search range (Time Range2) must be greater than or equal to the left end of the search range (Time Range1).

History Waveform Range

You can search the history waveforms in the range specified by Start Record and End Record of the HISTORY menu (see section 10.1)

Search Method

Search is performed in order from the newest history waveform.

History Map after the Search (Search Result)

The record numbers and time stamps of the waveforms that are found can be listed on the history map. If you set the Search Mode to OFF in the HISTORY menu, or turn OFF Param1 to Param4 and execute the search, the search result is reset.

10.4 Searching Waveforms Using the Search and Zoom Function

<For a description of this function, refer to page 2-26.>

Procedure

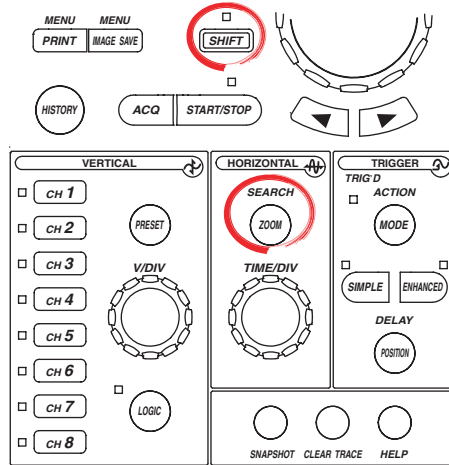

- To exit the menu during operation, press **ESC** located above the soft keys.
- In the procedural explanation below, the term *jog shuttle & SELECT* refers to the operation of selecting/setting items and entering values using the **jog shuttle** and **SELECT** and **RESET** keys. For details on this operation, see sections 4.1 or 4.2.
- For a description of the operation using a USB keyboard or a USB mouse, see section 4.3.

When waveform acquisition is stopped, you can search the displayed waveforms (within the display record length, see appendix 1) and display the waveforms that match the search conditions expanded on the screen. The following six search types are available. For the setup procedures of each type, see the pages indicated below.

- Edge -> Page 10-15
- Serial pattern -> Page 10-18
- Parallel pattern -> Page 10-20
- Pulse width -> Page 10-22
- Auto scroll -> Page 10-23
- SPI -> Page 10-76 (section 10.11)

Edge Search

1. Press **SHIFT+ZOOM (SEARCH)**. The SEARCH menu appears.

Selecting the Edge Search Type

2. Press the **Type** soft key. The Type menu appears.
3. Press the **Edge** soft key.

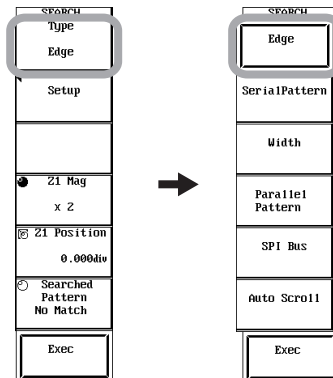

Setting the Search Conditions

4. Press the **Setup** soft key. The Setup dialog box opens.

Setting the Search Target Waveform, Level, Slope, and Hysteresis for Detecting Edges

5. Use **jog shuttle & SELECT** to select the search target waveform (Source box).
6. Use **jog shuttle & SELECT** to set the level for detecting the edge (Level box).
7. Use **jog shuttle & SELECT** to select which slope edge, rising or falling, is to be detected (Polarity box).
8. Use **jog shuttle & SELECT** to set the hysteresis (width of the level for detecting the edge, Hysteresis box).

Setting the Edge Detection Count and the Search Start Point

9. Use **jog shuttle & SELECT** to set the edge detection count (Count box).
10. Use **jog shuttle & SELECT** to set the search start point (Start Point box).
11. Press **ESC**. The Setup dialog box closes.

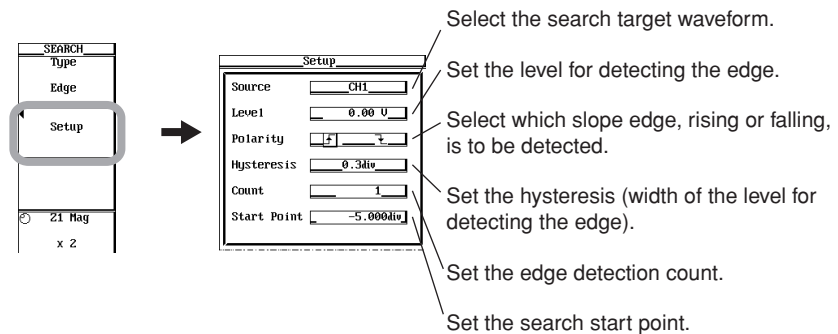

Selecting the Window for Displaying the Found Waveform (Zoom Waveform Display Frame)

This menu appears only when the zoom waveform display mode is set to Z1&Z2 or Main&Z1&Z2. For all other modes, the menu does not appear, because the selection is not necessary.

12. Press the **Result Window** soft key to select Z1 or Z2.

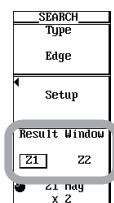

Executing/Aborting the Search

13. Press the **Exec** soft key. The search is executed, and the word Exec change to Abort. Each time a waveform that matches the search condition is detected, the search is aborted, and the word Abort changes to Exec.

To abort the search, press the **Abort** soft key. The search is aborted, and the word Abort changes to Exec.

When a waveform that matches the search condition is detected, the zoom box moves to that position and the zoom waveform display frame (the zoom waveform display frame selected in step 12 if the zoom waveform display mode is Z1&Z2 or Main&Z1&Z2) shows the detected waveform zoomed.

14. To search the next waveform using the same search condition, repeat step 13. The search can be repeated to the right edge of the screen or up to 1000 detections.

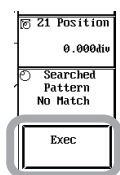

Redisplaying the Detected Waveforms

15. Press the **Searched Pattern** soft key.
16. Turn the **jog shuttle** to select the number (same as the detection count) of the detected waveform to be displayed. The zoom box moves to the position of the detected waveform of the selected number, and the zoom waveform display frame (the zoom waveform display frame selected in step 12 if the zoom waveform display mode is Z1&Z2 or Main&Z1&Z2) shows the detected waveform zoomed.

The numbers get larger as the detected waveforms become newer (detected waveforms to the right have larger numbers than those to the left).

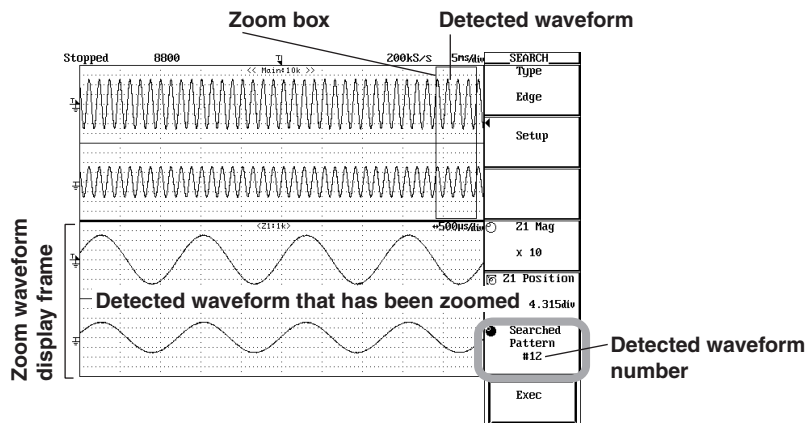

Changing the Zoom Rate and Zoom Position of the Detected Waveform

17. Change the zoom rate and zoom position of the waveform according to the procedures given in section 8.4.

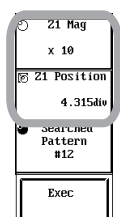

Serial Pattern (Serial Status Pattern) Search

1. Press **SHIFT+ZOOM (SEARCH)**. The SEARCH menu appears.

Selecting the “SerialPattern” Search Type

2. Press the **Type** soft key. The Type menu appears.
3. Press the **SerialPattern** soft key.

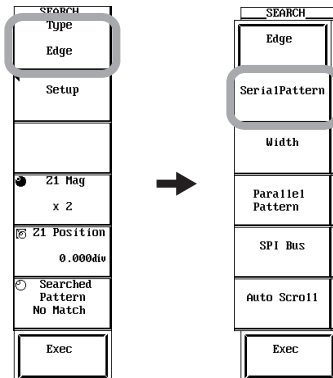

Setting the Search Conditions

4. Press the **Setup** soft key. The Setup dialog box opens.

Setting the Timing for Detecting the Status Pattern

5. Use **jog shuttle & SELECT** to select None (detect the patterns at a certain interval), or a channel from CH1 to CH8/4 (synchronize to the selected channel signal, Clock CH box).
 - If you select None, proceed to step 6.
 - If you select CH1 to CH8/4, proceed to step 7.
 - You can select up to CH4 and CH8 on the DL7440 and DL7480, respectively.

• Setting the Interval for Detecting Patterns (When None Is Selected)

6. Use **jog shuttle & SELECT** to set the interval for detecting the pattern (Interval box). Proceed to step 10.

• Setting the Detection Level, Slope, and Hysteresis of the Selected Synchronization Clock Signal (When CH1 to CH8/4 Is Selected)

7. Use **jog shuttle & SELECT** to set the level for detecting the synchronization clock (Level box).
8. Use **jog shuttle & SELECT** to select the slope, rising or falling, for detecting the synchronization clock (Polarity box).
9. Use **jog shuttle & SELECT** to set the hysteresis (width of the level for detecting the synchronization clock, Hysteresis box).

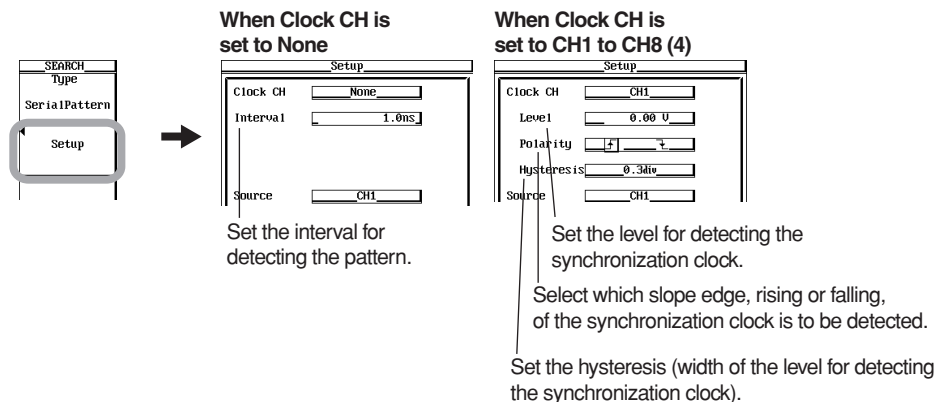

Setting the Search Target Waveform and Level for Determining the Status

10. Use **jog shuttle & SELECT** to select the search target waveform (Source box).
If the search target was set to the logic input (Pod A and Pod B), select the bit to be searched, and proceed to step 13.
11. Use **jog shuttle & SELECT** to set the level used to determine whether the status is high (Thr Upper box).
12. Use **jog shuttle & SELECT** to set the level used to determine whether the status is low (Thr Lower box).
 - When the search target waveform exceeds the specified level (Thr Upper), it is determined to be high.
 - When the search target waveform is below the specified level (Thr Lower), it is determined to be low.
 - For a description of the determination of the status when the search target waveform is between the levels specified by Thr Upper and Thr Lower (including the Thr Upper and Thr Lower values), see the explanation given later.

Setting the Status Determination Pattern and Search Start Point

13. Use **jog shuttle & SELECT** to select the preset status determination pattern of 64 points from A to D (Pattern box).
14. As necessary, use **jog shuttle & SELECT** to change the status determination pattern A to D by selecting the status of points 0 to 63 from H, L, and X.
If Clear Pattern is executed using jog shuttle & SELECT, all points are set to X.
15. Use **jog shuttle & SELECT** to set the search start point (Start Point box).
16. Press **ESC**. The Setup dialog box closes.

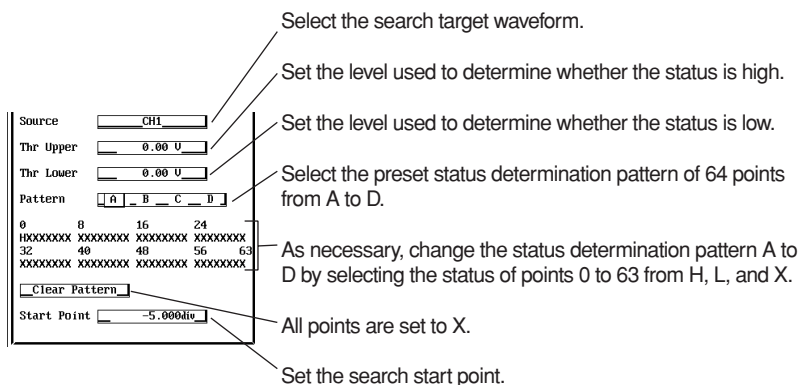

Selecting the Window for Displaying the Found Waveform (Zoom Waveform Display Frame)

17. The procedure is the same as step 12 on page 10-16.

Executing/Aborting the Search

18. The procedure is the same as steps 13 and 14 on page 10-17.

Redisplaying the Detected Waveforms

19. The procedure is the same as steps 15 and 16 on page 10-17.

Changing the Zoom Rate and Zoom Position of the Detected Waveform

20. Change the zoom rate and zoom position of the waveform according to the procedures given in section 8.4.

Parallel Pattern (Parallel Status Pattern) Search

1. Press **SHIFT+ZOOM (SEARCH)**. The SEARCH menu appears.

Selecting the “ParallelPattern” Search Type

2. Press the **Type** soft key. The Type menu appears.
3. Press the **ParallelPattern** soft key.

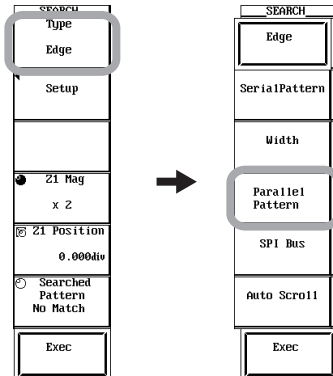

Setting the Search Conditions

4. Press the **Setup** soft key. The Setup dialog box opens.

Setting the Timing for Detecting the Status Pattern

5. Use **jog shuttle & SELECT** to select None (detect the patterns of all waveforms), or a channel from CH1 to CH8/4 (synchronize to the selected channel signal and detect the patterns of all other waveforms, Clock CH box).
 - If you select None, proceed to step 9.
 - If you select CH1 to CH8/4, proceed to step 6.
 - You can select up to channel CH4 and CH8 on the DL7440 and DL7480, respectively.

Setting the Detection Slope, Level, and Hysteresis of the Selected Synchronization Clock Signal (When CH1 to CH8/4 Is Selected)

6. Use **jog shuttle & SELECT** to select the slope, rising or falling, for detecting the synchronization clock (Pattern box).
7. Use **jog shuttle & SELECT** to set the level for detecting the synchronization clock (Level box).
8. Use **jog shuttle & SELECT** to set the hysteresis (width of the level for detecting the synchronization clock, Hysteresis box).

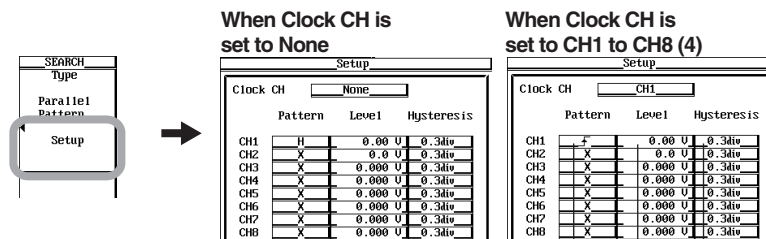

Select which slope edge, rising or falling, of the synchronization clock is to be detected.

Set the level for detecting the synchronization clock.

Set the hysteresis (width of the level for detecting the synchronization clock).

Setting the Determination Pattern, Level, and Hysteresis of the Status of Waveforms (CH, Math, Pod A and Pod B) Other Than the Waveform of the Channel Selected as the Synchronization Clock Signal

9. Use **jog shuttle & SELECT** to select the status determination pattern from H, L, and X (Pattern box).
10. Use **jog shuttle & SELECT** to set the level for determining whether the status is high or low (Level box).
11. Use **jog shuttle & SELECT** to set the hysteresis (width of the level for detecting high or low) (Hysteresis box).
 - When the search target waveform exceeds the specified upper limit of hysteresis, it is determined to be high.
 - When the search target waveform is below the specified lower limit of hysteresis, it is determined to be low.
 - For a description of the determination of the status when the search target waveform is within the specified hysteresis (including the upper and lower limits of hysteresis), see the explanation given later.

Setting the Search Start Point

12. Use **jog shuttle & SELECT** to set the search start point (Start Point box).
13. Press **ESC**. The Setup dialog box closes.

Set the determination pattern, level, and hysteresis of the status of waveforms (CH, Math, Pod A and Pod B) other than the waveform of the channel selected as the synchronization clock signal.

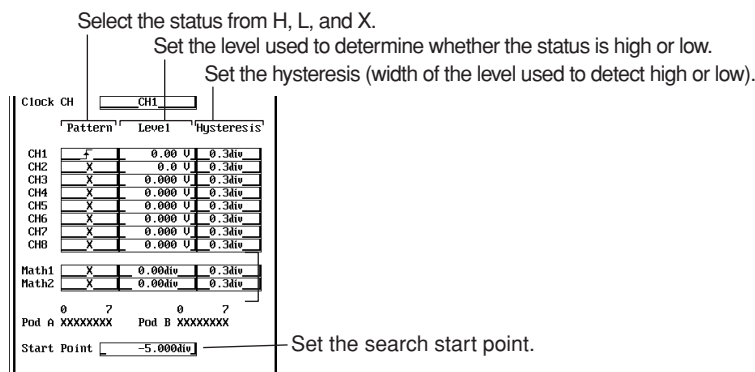

Selecting the Window for Displaying the Found Waveform (Zoom Waveform Display Frame)

14. The procedure is the same as step 12 on page 10-16.

Executing/Aborting the Search

15. The procedure is the same as steps 13 and 14 on page 10-17.

Redisplaying the Detected Waveforms

16. The procedure is the same as steps 15 and 16 on page 10-17.

Changing the Zoom Rate and Zoom Position of the Detected Waveform

17. Change the zoom rate and zoom position of the waveform according to the procedures given in section 8.4.

Pulse Width Search

1. Press **SHIFT+ZOOM (SEARCH)**. The SEARCH menu appears.

Selecting the “Width” Search Type

2. Press the **Type** soft key. The Type menu appears.
3. Press the **Width** soft key.

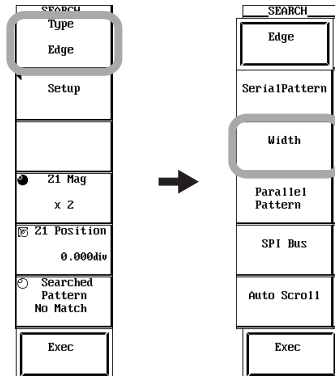

Setting the Search Conditions

4. Press the **Setup** soft key. The Setup dialog box opens.

Setting the Pulse Width Determination Type, Search Target Waveform, Level, Polarity, Hysteresis, Pulse Width, and Search Start Point

5. Use **jog shuttle & SELECT** to select the determination type (Type box).
6. Use **jog shuttle & SELECT** to select the search target waveform (Source box).
7. Use **jog shuttle & SELECT** to set the level for determining whether the polarity is high or low (Level box).
8. Use **jog shuttle & SELECT** to select the polarity, high or low, used to perform determination (Polarity box).
9. Use **jog shuttle & SELECT** to set the hysteresis (width of the level for detecting the edge) (Hysteresis box).
 - The interval from the point where the level of the search target waveform passes from below the specified lower limit of hysteresis to above and including the upper limit of hysteresis to the point where the level changes from above the specified upper limit of hysteresis to below and including the lower limit of hysteresis is determined to be the high pulse width.
 - The interval from the point where the level of the search target waveform passes from above the specified upper limit of hysteresis to below and including the lower limit of hysteresis to the point where the level changes from below the specified lower limit of hysteresis to above and including the upper limit of hysteresis is determined to be the low pulse width.
 - For the determination of the polarity when the change in the search target level does not apply to high or low conditions described above, see the explanation given later.
10. Use **jog shuttle & SELECT** to set the pulse width (determination time) used as the determination reference (Time box).
11. Use **jog shuttle & SELECT** to set the search start point (Start Point box).
12. Press **ESC**. The Setup dialog box closes.

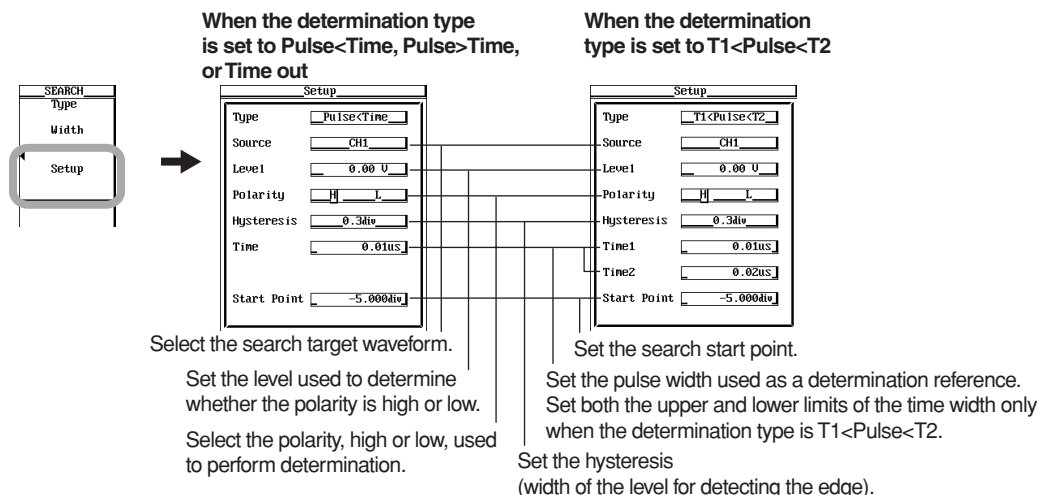

Selecting the Window for Displaying the Found Waveform (Zoom Waveform Display Frame)

13. The procedure is the same as step 12 on page 10-16.

Executing/Aborting the Search

14. The procedure is the same as steps 13 and 14 on page 10-17.

Redisplaying the Detected Waveforms

15. The procedure is the same as steps 15 and 16 on page 10-17.

Changing the Zoom Rate and Zoom Position of the Detected Waveform

16. Change the zoom rate and zoom position of the waveform according to the procedures given in section 8.4.

Auto Scroll Search

1. Press **SHIFT+ZOOM (SEARCH)**. The SEARCH menu appears.

Selecting the "Auto Scroll" Search Type

2. Press the **Type** soft key. The Type menu appears.
3. Press the **Auto Scroll** soft key.

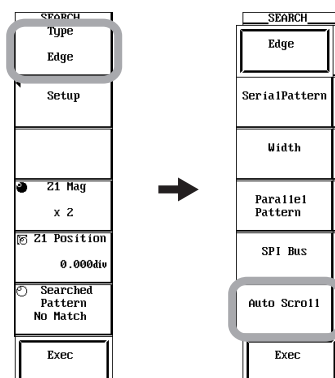

Setting the Auto Scroll Conditions

- 4. Press the **Direction** soft key to set the auto scroll direction to << or >>.
- 5. Press the **Speed** soft key.
- 6. Turn the **jog shuttle** to set the auto scroll speed.

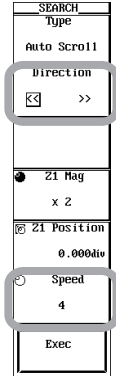

Selecting the Window for Displaying the Auto Scrolled Waveform (Zoom Waveform Display Frame)

- 7. The procedure is the same as step 12 on page 10-16.

Executing/Aborting Auto Scroll

- 8. Press the **Exec** soft key. Auto scroll is executed, and the word Exec changes to Abort.

To abort auto scroll, press the **Abort** soft key. Auto scroll is aborted, and the word Abort changes to Exec.

When auto scroll is executed, the zoom box moves in the direction selected in step 4, and the zoom waveform display frame (the zoom waveform display frame selected in step 12 if the zoom waveform display mode is Z1&Z2 or Main&Z1&Z2) shows the waveform zoomed.

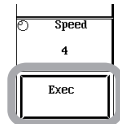

Changing the Zoom Rate and Zoom Position of the Detected Waveform

- 9. Change the zoom rate and zoom position of the waveform according to the procedures given in section 8.4.

Explanation

This section explains the setup procedures for searching the displayed waveforms (within the display record length, see appendix 1) and displaying the waveforms that match the search conditions expanded on the screen when waveform acquisition is stopped.

Search Type

You can select from the following six search types.

Edge

Search is performed on the number of times the waveform goes above or below (rising or falling) a specified level.

Serial pattern

Search is performed on whether the serial status pattern of the waveform (status pattern of the waveform that changes over time) is the same as the pattern set using High (H), Low (L), and Don't Care (X).

Parallel pattern

Search is performed on whether the parallel status pattern of the waveforms (status pattern of the waveforms at the same point) is the same as the pattern set using High (H), Low (L), and Don't Care (X). For Pod A and Pod B, the search is performed using bit patterns.

Pulse width

Search is performed on whether the pulse width of the waveform above or below a specified level is shorter or longer than the specified determination time.

Auto scroll

The zoom position automatically moves (auto scroll) in the specified direction. You can confirm the zoomed waveform and stop the scroll operation at an arbitrary position.

SPI

See section 10.11.

Edge Search Conditions

The following conditions can be specified.

Search Target Waveform

You can select the search target waveform.

DL7440

You can select the target waveform from CH1 to CH4, Math1, and Math2.

DL7480

You can select the target waveform from CH1 to CH8, Math1, and Math2.

Level

You can set the level for detecting the rising or falling edge. The selectable range is 8 divisions within the screen. The resolution is 0.01 divisions.

Slope

You can select which slope edge, rising or falling, is to be detected.

 Rising slope

 Falling slope

10.4 Searching Waveforms Using the Search and Zoom Function

Hysteresis

You can set the hysteresis. The selectable range is 0.3 divisions to 4.0 divisions. The resolution is 0.1 divisions.

- When the level of the search target waveform changes from below the specified lower limit of hysteresis to above and including the upper limit of hysteresis, it is detected as a rising edge.
- When the level of the search target waveform changes from above the specified upper limit of hysteresis to below and including the lower limit of hysteresis, it is detected as a falling edge.
- For all other cases, it is not detected as an edge.

Detection Count

- You can set the edge detection count. The selectable range is 1 to 1000000.
- If the search is aborted in the middle of the operation and the next search is resumed, the rising or falling edge of the previous detection position is counted as the 1st edge detection count.

Search Start Point

You can set the search start point. The selectable range is ± 5 divisions. The resolution is $10 \text{ divisions} \div \text{the display record length}$. For a description of the display record length, see appendix 1.

Edge Search Example

When the edge is set to rising and the detection count is set to 2

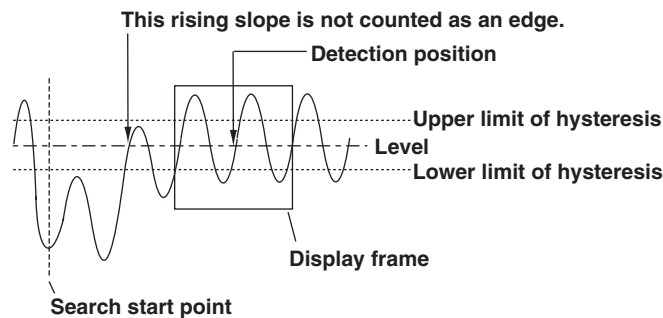

Search Conditions of Serial Patterns

The following conditions can be specified.

Clock Channel

Detects the status pattern in sync with the selected clock signal (clock channel).

DL7440

You can select from CH1 to CH4, and None.

DL7480

You can select from CH1 to CH8, and None.

- **When the Clock Channel Is Set to None**

Detection Interval

You can set the interval for detecting the pattern.

- **When the Clock Channel Is Set to CH1 to CH8/4**



You can set the detection level, slope, and hysteresis of the selected synchronization clock signal.

- **Level**

You can set the level for detecting the synchronization clock. The selectable range is 8 divisions within the screen. The resolution is 0.01 divisions.

• **Slope**

You can select which slope edge, rising or falling, of the synchronization clock is to be detected.

	Rising slope
	Falling slope

• **Hysteresis**

You can set the hysteresis. The selectable range is 0.3 divisions to 4.0 divisions. The resolution is 0.1 divisions.

- When the level of the search target waveform changes from below the specified lower limit of hysteresis to above and including the upper limit of hysteresis, it is detected as a synchronization clock.
- When the level of the search target waveform changes from above the specified upper limit of hysteresis to below and including the lower limit of hysteresis, it is detected as a synchronization clock.
- For all other cases, it is not detected as a synchronization clock.

Search Target Waveform

You can select the search target waveform.

DL7440

You can select the target waveform from CH1 to CH4, Math1, Math2, Pod A, and Pod B.

DL7480

You can select the target waveform from CH1 to CH8, Math1, Math2, Pod A, and Pod B.

* In the case of the logic input (Pod A and Pod B), you can select the search target bit.

Level for Determining the Status

You can set the level for determining the status of the search target waveform. The selectable range is 8 divisions within the screen. The resolution is 0.01 divisions. Thr Upper must be greater than or equal to Thr Lower.

Level for determining high (Thr Upper)

You can set the level for determining the high status. When the search target waveform exceeds the specified level, it is determined to be high.

Level for determining low (Thr Lower)

You can set the level for determining the low status. When the search target waveform is below the specified level, it is determined to be low.

Between Thr Upper and Thr Lower

The status when the search target waveform is between the levels specified by Thr Upper and Thr Lower (including the Thr Upper and Thr Lower values) (A and B in the figure below) is determined to be the same status (true) as the status at the same point of the determination pattern specified on the next page and is handled as a section where the search condition is met.

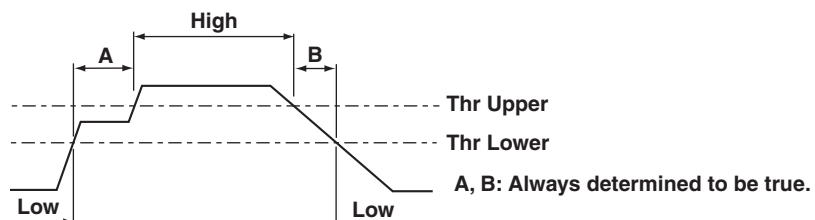

10.4 Searching Waveforms Using the Search and Zoom Function

Status Determination Pattern

You can set four types, A to D, of status determination patterns. The status of 64 points can be specified using the H (High), L (Low), and X (Don't Care) designations.

H
Status when the waveform is greater than Thr Upper (1 in the case of logic input)

L
Status when the waveform is less than Thr Lower (0 in the case of logic input)

X
No determination.

* If you execute Clear Pattern, all 64 points are set to Xs.

Search Start Point

You can set the search start point. The selectable range is ± 5 divisions. The resolution is $10 \text{ divisions} \div \text{the display record length}$. For a description of the display record length, see appendix 1. However, if the clock channel is set to None, the search start point when executing the search is defined as follows:

- Taking the first rising or falling edge located to the right of the specified Start Point on the screen as the reference point, the search start point is set to the point 1/2 the specified interval to the right of the reference point.

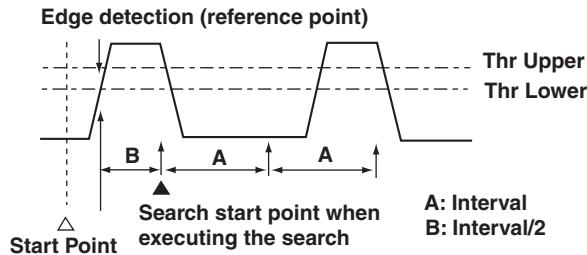

- When the interval between the Start Point and the search start position defined above is greater than the detection interval, the search start point is set by moving the point back by intervals specified by Interval so that the interval between the Start Point and the search start point is within Interval and the Start Point is not exceeded (the search start point shall not be to the left of the Start Point on the screen).

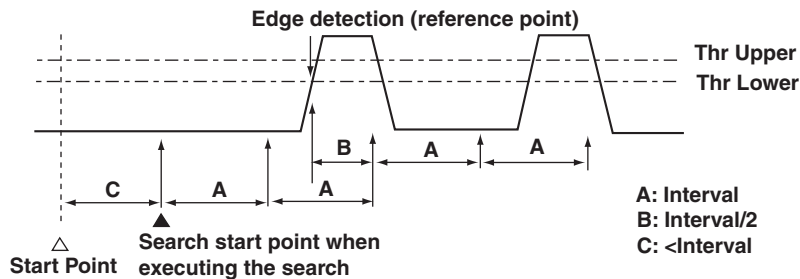

- Rising and falling edges are not detected in the hysteresis range (including the upper and lower limits of hysteresis) of the Clock CH.

Search Conditions of Parallel Patterns

The following conditions can be specified.

Clock Channel

Detects the status pattern in sync with the selected clock signal (clock channel).

DL7440

You can select from CH1 to CH4, and None.

DL7480

You can select from CH1 to CH8, and None.

- **When the Clock Channel Is Set to None**

The status patterns of all waveforms are determined.

- **When the Clock Channel Is Set to CH1 to CH8/4**

You can set the detection slope, level, and hysteresis of the selected synchronization clock signal.

- **Slope**

You can select which slope edge, rising or falling, of the synchronization clock is to be detected.

 Rising slope

 Falling slope

- **Level**

You can set the level for detecting the synchronization clock. The selectable range is 8 divisions within the screen. The resolution is 0.01 divisions.

- **Hysteresis**

You can set the hysteresis. The selectable range is 0.3 divisions to 4.0 divisions. The resolution is 0.1 divisions.

- When the level of the search target waveform changes from below the specified lower limit of hysteresis to above and including the upper limit of hysteresis, it is detected as a synchronization clock.
- When the level of the search target waveform changes from above the specified upper limit of hysteresis to below and including the lower limit of hysteresis, it is detected as a synchronization clock.
- For all other cases, it is not detected as a synchronization clock.

Search Target Waveform

The search target waveforms are all the waveforms that are not selected as the clock channel. For each waveform, you can set the determination status (Pattern) and the level and hysteresis for determining the status.

- **Determination Status**

The status of each waveform can be specified using the H (High), L (Low), and X (Don't Care) symbols. In the case of the logic input (Pod A and Pod B), you can set the status on each bit.

H

Status when the waveform is greater than Thr Upper (1 in the case of logic input)

L

Status when the waveform is less than Thr Lower (0 in the case of logic input)

X

No determination.

10.4 Searching Waveforms Using the Search and Zoom Function

- **Level**

You can set the level used to determine whether the status is high or low. The selectable range is 8 divisions within the screen. The resolution is 0.01 divisions.

- **Hysteresis**

You can set the hysteresis. The selectable range is 0.3 divisions to 4.0 divisions. The resolution is 0.1 divisions.

- When the search target waveform exceeds the specified upper limit of hysteresis, it is determined to be high.
- When the search target waveform is below the specified lower limit of hysteresis, it is determined to be low.
- The status when the search target waveform is within the specified hysteresis (including the upper and lower limits of hysteresis), A and B in the figure below) is determined to be the same status (true) as the determination status (Pattern) described two sections earlier, and is handled as a level where the search condition is met.

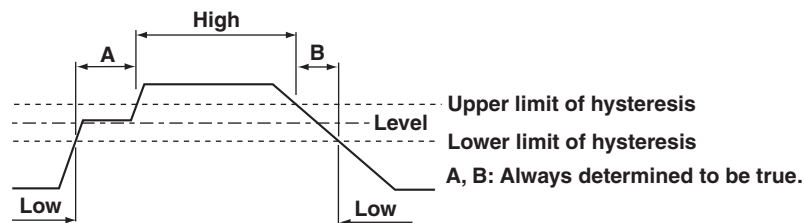

Search Start Point

You can set the search start point. The selectable range is ± 5 divisions. The resolution is 10 divisions \div the display record length. For a description of the display record length, see appendix 1.

Search Conditions of the Pulse Width

The following conditions can be specified.

Determination Type

You can select the type used to determine the relationship between the pulse width of the search target waveform and the specified determination time.

Pulse<Time	Searches the section where the pulse width of the search target waveform is shorter than the specified determination time.
Pulse>Time	Searches the section where the pulse width of the search target waveform is longer than the specified determination time.
T1<Pulse<T2	Searches the section where the pulse width of the search target waveform is within than the specified determination time range.
Time Out	Searches the section where the pulse width of the search target waveform exceeds the specified determination time. The displayed position in the zoom display differs from the Pulse>Time case.

Pulse<Time

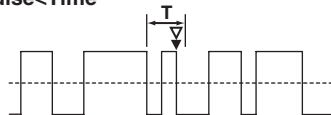

Pulse>Time

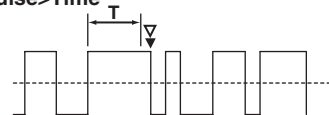

T1<Pulse<T2

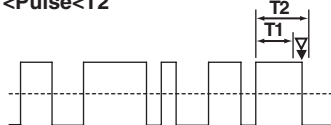

Time Out

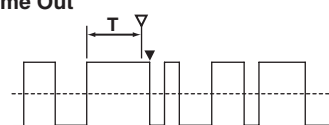

T, T1, T2: Specified determination time

▽: Center position when zooming
▼: Search start point for the next search

Search Target Waveform

You can select the search target waveform.

DL7440

You can select the target waveform from CH1 to CH4, Math1, and Math2.

DL7480

You can select the target waveform from CH1 to CH8, Math1, and Math2.

Level

You can set the level used to determine whether the polarity of the search target waveform is high or low. The selectable range is 8 divisions within the screen. The resolution is 0.01 divisions.

Polarity

You can select the polarity, high or low, used to perform determination.

High

Uses the pulse width of the waveform that is greater than or equal to the specified level (including the hysteresis condition) in the determination.

Low

Uses the pulse width of the waveform that is less than or equal to the specified level (including the hysteresis condition) in the determination.

Hysteresis

You can set the hysteresis. The selectable range is 0.3 divisions to 4.0 divisions. The resolution is 0.1 divisions.

- The interval from the point where the level of the search target waveform passes from below the specified lower limit of hysteresis to above and including the upper limit of hysteresis to the point where the level changes from above the specified upper limit of hysteresis to below and including the lower limit of hysteresis is determined to be the high pulse width.
- The interval from the point where the level of the search target waveform passes from above the specified upper limit of hysteresis to below and including the lower limit of hysteresis to the point where the level changes from below the specified lower limit of hysteresis to above and including the upper limit of hysteresis is determined to be the low pulse width.
- When the change in the search target level does not apply to high or low conditions described above, it is not detected as a high or low pulse width. It is handled as an area where the search condition is not met.

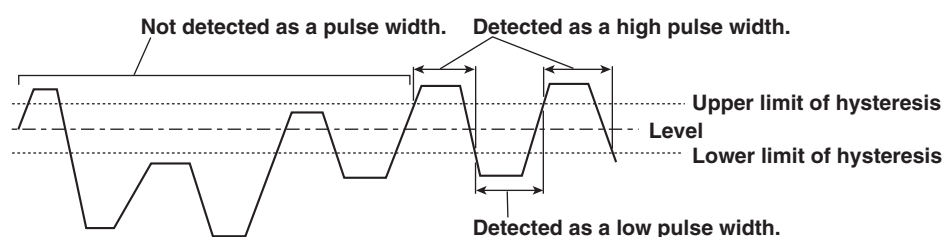
**Determination Time**

You can set the time used as a determination reference. The value specified here and the pulse width detected by the specified search condition are compared, and determination is made as to whether the result matches the selected type. The selectable range is (1/sample rate) to the display range. For a description of the sample rate, see appendix 1.

Search Start Point

You can set the search start point. The selectable range is ± 5 divisions. The resolution is 10 divisions \div the display record length. For a description of the display record length, see appendix 1.

Search Conditions of Auto Scroll

The following conditions can be specified.

When auto scroll is in progress, you can only set the direction and speed of the auto scroll operation.

Auto Scroll Direction

You can select the auto scroll direction.

<<

The zoom box automatically scrolls to the left. It can scroll up to the left end of the screen.

>>

The zoom box automatically scrolls to the right. It can scroll up to the right end of the screen.

Speed

You can set the auto scroll speed. The selectable range is 1 to 7. The larger the value, the faster the scrolling.

Window for Displaying the Found Waveform

When the zoom waveform display mode is Z1&Z2 or Main&Z1&Z2, you can select the zoom waveform display frame, Z1 or Z2, where the waveforms that are found are to be displayed. For all other modes, the menu does not appear, because the selection is not necessary.

Detection Count and Redisplay of the Detected Waveform

Detection Count

For serial pattern, parallel pattern, and pulse width searches, the search can be repeated using the same search conditions up to the right end of the screen or up to 1000 detections.

Redisplaying the Detected Waveforms

For serial pattern, parallel pattern, and pulse width searches, the waveforms detected in the past can be displayed.

Zoom Rate and Zoom Position of the Detected Waveforms

The detected waveforms are displayed in the zoom waveform display frame. The zoom rate and the zoom position of these waveforms can be changed. For a description of the procedure, see section 8.4.

Note

- Searching is not possible while waveform acquisition is in progress.
 - Search cannot be performed on the results of the power spectrum computation.
 - The search results become invalid when you perform the following operations.
 - When waveform acquisition is started.
 - When Search Setup is changed.
 - When the phase of the search target waveform (Source) or synchronization clock signal (Clock CH) is shifted.
 - When the computation settings are changed.
 - Searching is not possible in interleave mode when Clock CH is set to multiple channels.
 - Searching is not possible if all the patterns are set to X.
 - Only the patterns of waveforms that are displayed are searched.
 - In the determination of serial pattern search, the points between Thr Upper and Thr Lower are always determined as True (match the specified status). If such points are included at the time the status pattern is detected, this fact is displayed as a message.
 - Points within the hysteresis (including the upper and lower limits of the hysteresis) in the determination when using the parallel pattern for the search are always determined as True (match the specified determination status). If such points are included, this fact is displayed as a message.
-

10.5 Making Cursor Measurements

<For a description of this function, refer to page 2-29.>

Procedure

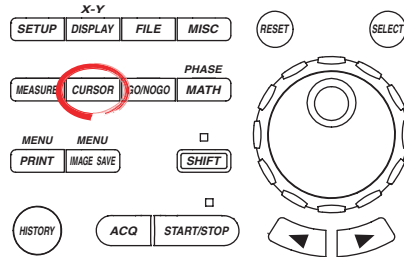

- To exit the menu during operation, press **ESC** located above the soft keys.
- In the procedural explanation below, the term *jog shuttle & SELECT* refers to the operation of selecting/setting items and entering values using the **jog shuttle** and **SELECT** and **RESET** keys. For details on this operation, see sections 4.1 or 4.2.
- For a description of the operation using a USB keyboard or a USB mouse, see section 4.3.

Cursors can be placed on the displayed waveform (within the display record length, see appendix 1) and various types of measured values at the cross point of the cursor and waveform can be displayed. The following four types of cursors are available. For the setup procedures of each type, see the pages indicated below.

- Horizontal cursors -> Page 10-33
- Vertical cursors -> Page 10-35
- Marker cursors -> Page 10-37
- Angle cursors -> Page 10-39

Measuring Waveforms Using Horizontal Cursors

1. Press **CURSOR**. The CURSOR menu appears.

Selecting the Horizontal Cursor

2. Press the **Type** soft key. The Type menu appears.
3. Press the **Horizontal** soft key.

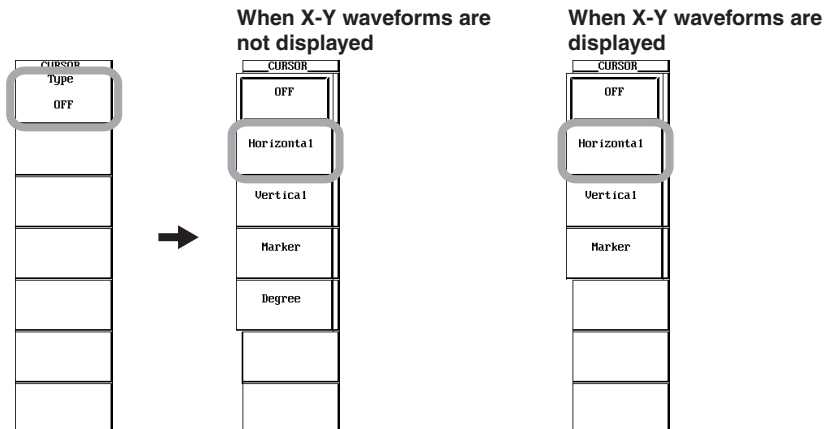

Selecting the Waveform to Be Measured

When X-Y Waveforms Are Not Displayed

4. Press the **Trace** soft key. The Trace menu appears.
5. Press the **CH1** to **CH8/4**, **Math1**, or **Math2** soft key to select the waveform to be measured.
 - On the DL7440, select CH1 to CH4, Math1, or Math2.
 - On the DL7480, select CH1 to CH8, Math1, or Math2. CH7, CH8, Math1, and Math2 appear when you press the To Page 2 soft key.

When X-Y Waveforms Are Displayed

4. Press the **Trace** soft key to select **XY1** or **XY2**. Proceed to step 6.

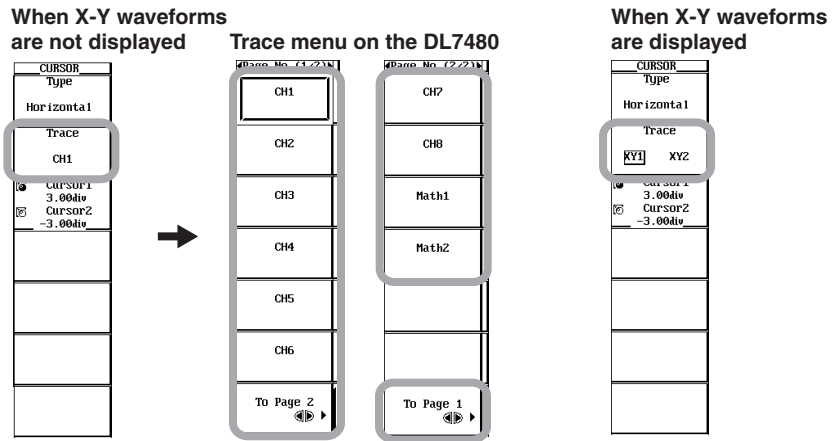

Moving the Cursors

6. Press the **Cursor1/Cursor2** soft key to set the jog shuttle control to Cursor1, Cursor2, or both Cursor1 and Cursor2.
 - Select Cursor1 to move Cursor1.
 - Select Cursor2 to move Cursor2.
 - If you select both Cursor1 and Cursor2, you can move Cursor1 and Cursor2 vertically without changing the spacing between the two. The value of the digit being specified by Cursor1 changes.
7. Turn the **jog shuttle** to move the cursor.

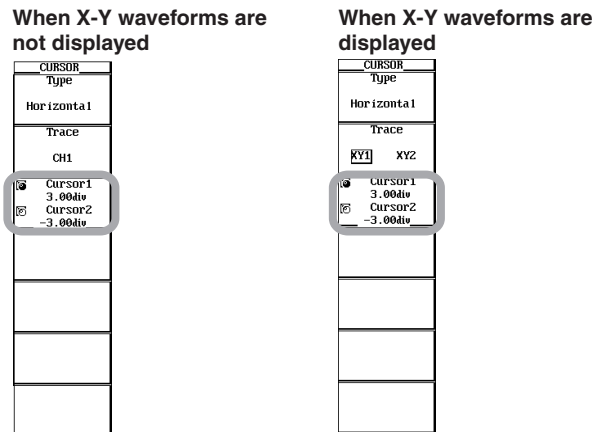

Measuring Waveforms Using Vertical Cursors

1. Press **CURSOR**. The CURSOR menu appears.

Selecting the Vertical Cursor

2. Press the **Type** soft key. The Type menu appears.
3. Press the **Vertical** soft key.

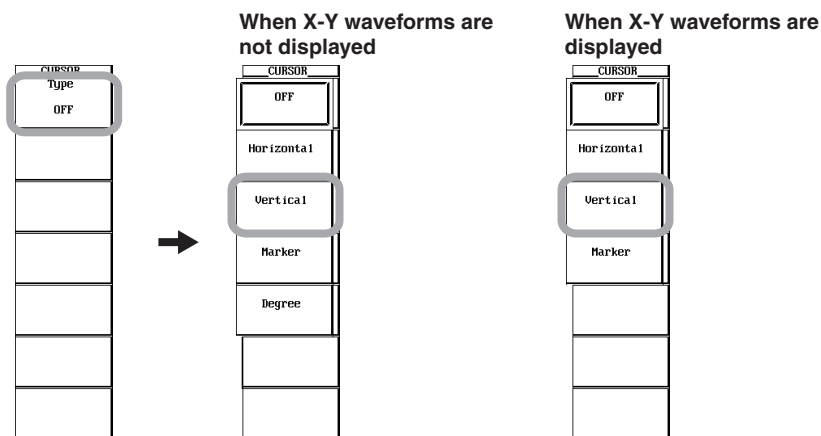

Selecting the Waveform to Be Measured

When X-Y Waveforms Are Not Displayed

4. Press the **Trace** soft key. The Trace menu appears.
5. Press the **All, CH1 to CH8(4), Math1, Math2, Pod A, Pod B, or Pod A & Pod B** soft key to select the waveform to be measured.
 - On the DL7440, select All, CH1 to CH4, Math1, Math2, Pod A, Pod B, or Pod A & Pod B. Math1, Math2, Pod A, Pod B, and Pod A & Pod B appear when you press the Next (1/2) soft key.
 - On the DL7480, Select All, CH1 to CH8, Math1, Math2, Pod A, Pod B, or Pod A & Pod B. CH5, CH6, CH7, CH8, and Math1 appear when you press the To Page 2 soft key. Math2, Pod A, Pod B, and Pod A & Pod B appear when you press the To Page 3 soft key.
 - If you select all, CH1 to CH8/4, Math1, or Math2, proceed to step 10.
 - If you select Pod A, Pod B, or Pod A & Pod B, proceed to step 6.

When X-Y Waveforms Are Displayed

4. Press the **Trace** soft key to select XY1 or XY2. Proceed to step 10.

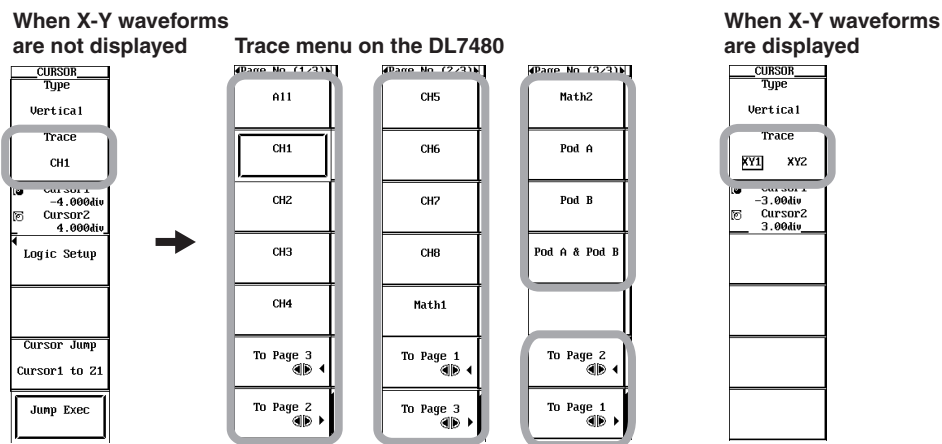

Selecting the Display Format of the Logic Input (When X-Y Waveforms Are Not Displayed)

6. Press the **Logic Setup** soft key. The Logic Setup dialog box opens.
7. Use **jog shuttle & SELECT** to select the notation system.
8. Use **jog shuttle & SELECT** to select the read order of bit data.
9. Press **ESC**. The Logic Setup dialog box closes.

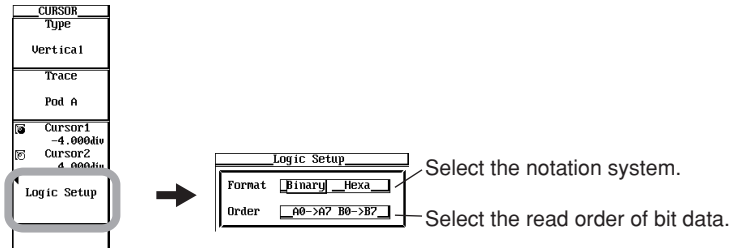

Moving the Cursors

10. Press the **Cursor1/Cursor2** soft key to set the jog shuttle control to Cursor1, Cursor2, or both Cursor1 and Cursor2.
 - Select Cursor1 to move Cursor1.
 - Select Cursor2 to move Cursor2.
 - If you select both Cursor1 and Cursor2, you can move Cursor1 and Cursor2 horizontally without changing the spacing between the two. The value of the digit being specified by Cursor1 changes.
11. Turn the **jog shuttle** to move the cursor.

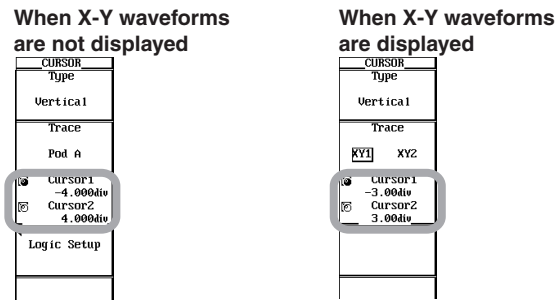

Jumping the Cursor to the Zoom Waveform Display Frame (When X-Y Waveforms Are Not Displayed)

12. Press the **Cursor Jump** soft key. The Cursor Jump menu appears.
13. Press the **Cursor1 to Z1, Cursor1 to Z2, Cursor2 to Z1, or Cursor2 to Z2** soft key to select the cursor and the jump destination.
14. Press the **Jump Exec** soft key. The cursor jumps to the specified zoom waveform display frame.

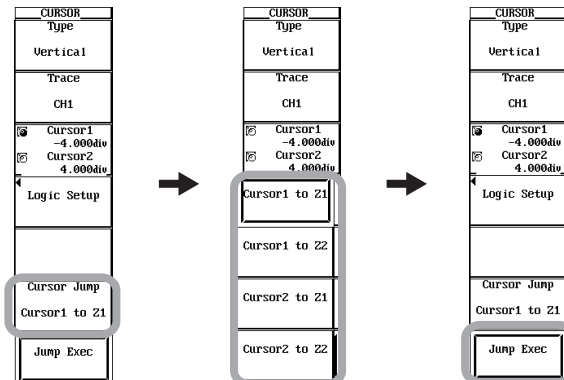

Measuring Waveforms Using Marker Cursors

1. Press **CURSOR**. The CURSOR menu appears.

Selecting the Marker Cursor

2. Press the **Type** soft key. The Type menu appears.
3. Press the **Marker** soft key.

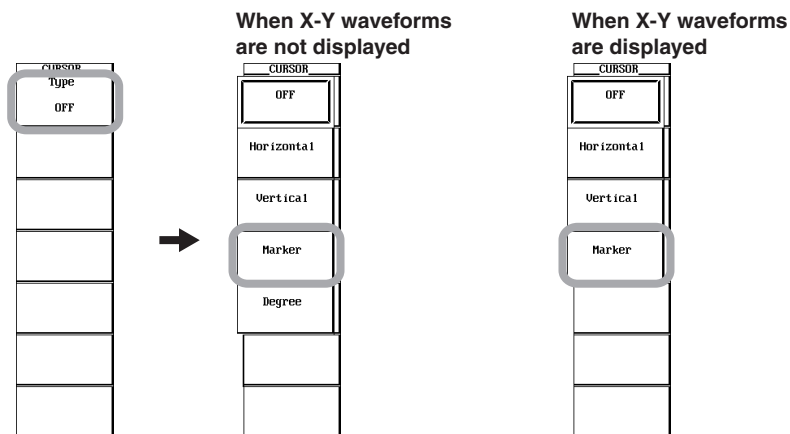

Selecting the Waveform to Be Measured

When X-Y Waveforms Are Not Displayed

4. Press the **Select** soft key to select the marker from M1 to M4.
5. Press the **Trace** soft key. The Trace menu appears.
6. Press the **CH1** to **CH8/4**, **Math1**, or **Math2** soft key to select the waveform to be measured.
 - On the DL7440, select CH1 to CH4, Math1, or Math2.
 - On the DL7480, select CH1 to CH8, Math1, or Math2. CH7, CH8, Math1, and Math2 appear when you press the To Page 2 soft key.

When X-Y Waveforms Are Displayed

4. Press the **Trace** soft key to select **XY1** or **XY2**. Proceed to step 7.

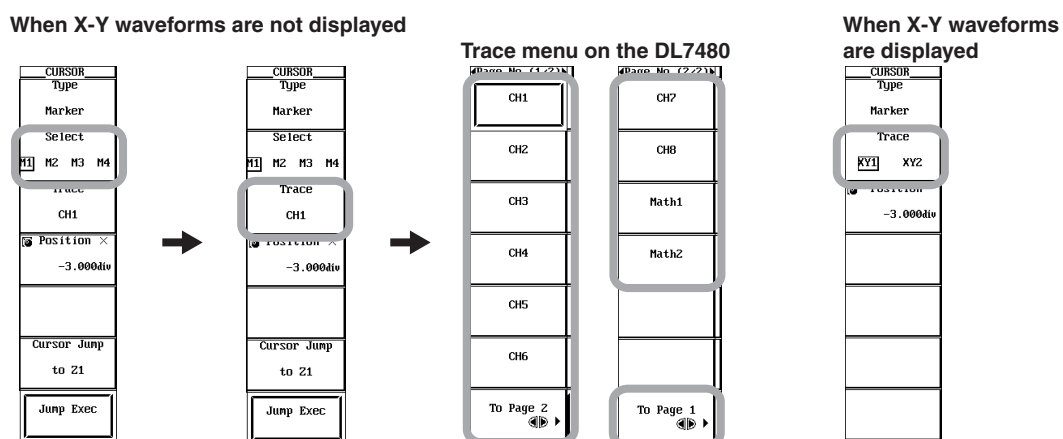

Moving the Cursors

- Turn the **jog shuttle** to move the cursor. The Position value changes.

When X-Y waveforms are not displayed

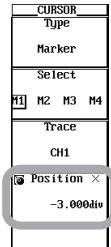

When X-Y waveforms are displayed

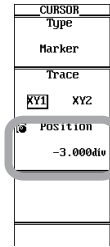

Jumping the Cursor to the Zoom Waveform Display Frame (When X-Y Waveforms Are Not Displayed)

- Press the **Cursor Jump** soft key. The Cursor Jump menu appears.
- Press the **to Z1** or **to Z2** soft key to select the jump destination of the cursor.
- Press the **Jump Exec** soft key. The cursor jumps to the specified zoom waveform display frame.

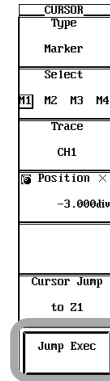
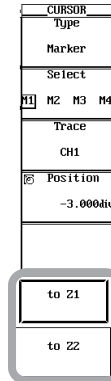
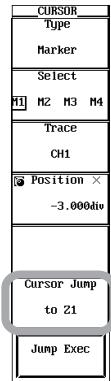

Measuring Waveforms Using Angle Cursors (When X-Y Waveforms Are Not Displayed)

1. Press **CURSOR**. The CURSOR menu appears.

Selecting the “Degree” Angle Cursor

2. Press the **Type** soft key. The Type menu appears.
3. Press the **Degree** soft key.

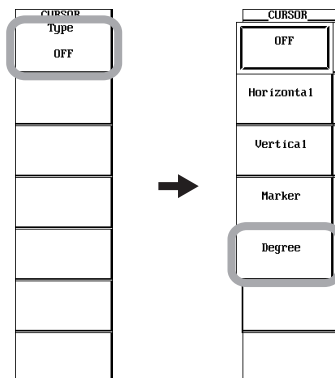

Selecting the Waveform to Be Measured

4. Press the **Trace** soft key. The Trace menu appears.
5. Press the **All**, **CH1 to CH8/4**, **Math1**, **Math2**, **Pod A**, **Pod B**, or **Pod A & Pod B** soft key to select the waveform to be measured.
 - On the DL7440, select All, CH1 to CH4, Math1, Math2, Pod A, Pod B, or Pod A & Pod B. Math1, Math2, Pod A, Pod B, and Pod A & Pod B appear when you press the Next (1/2) soft key.
 - On the DL7480, Select All, CH1 to CH8, Math1, Math2, Pod A, Pod B, or Pod A & Pod B. CH5, CH6, CH7, CH8, and Math1 appear when you press the To Page 2 soft key. Math2, Pod A, Pod B, and Pod A & Pod B appear when you press the To Page 3 soft key.

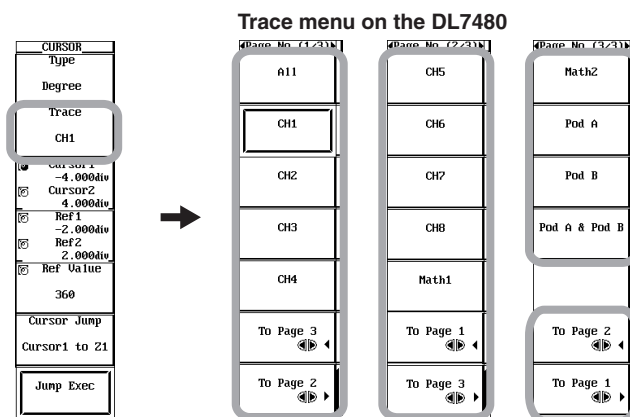

Setting the Cursor, Reference Cursor, and Reference Angle

Moving the Cursors

6. Press the **Cursor1/Cursor2** soft key to set the jog shuttle control to Cursor1, Cursor2, or both Cursor1 and Cursor2.
 - Select Cursor1 to move Cursor1.
 - Select Cursor2 to move Cursor2.
 - If you select both Cursor1 and Cursor2, you can move Cursor1 and Cursor2 horizontally without changing the spacing between the two. The value of the digit being specified by Cursor1 changes.
7. Turn the **jog shuttle** to move the cursor.

Moving the Reference Cursors

8. Press the **Ref1/Ref2** soft key to set the jog shuttle control to Ref1, Ref2, or both Ref1 and Ref2.
 - Select Ref1 to move Ref1.
 - Select Ref2 to move Ref2.
 - If you select both Ref1 and Ref2, you can move Ref1 and Ref2 horizontally without changing the spacing between the two. The value of the digit being specified by Ref1 changes.
9. Turn the **jog shuttle** to move the reference cursor.

Setting the Reference Angle

10. Press the **Ref Value** soft key.
11. Turn the **jog shuttle** to set the reference angle.

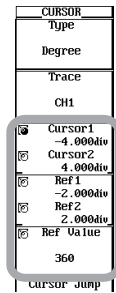

Jumping the Cursor to the Zoom Waveform Display Frame

12. Press the **Cursor Jump** soft key. The Cursor Jump menu appears.
13. Press the **Cursor1 to Z1**, **Cursor1 to Z2**, **Cursor2 to Z1**, or **Cursor2 to Z2** soft key to select the cursor and the jump destination.
14. Press the **Jump Exec** soft key. The cursor jumps to the specified zoom waveform display frame.

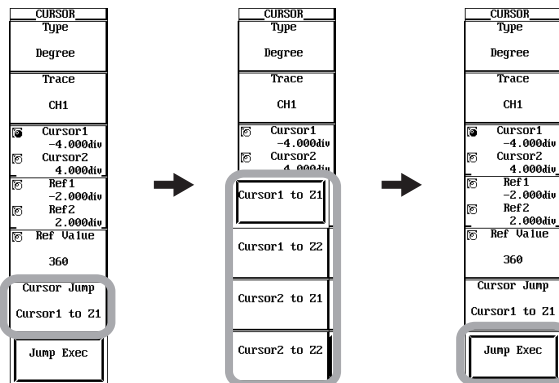

Explanation

This section explains the setup procedures for placing cursors on the displayed waveform (within the display record length, see appendix 1) and displaying various types of measured values at the cross point of the cursor and waveform. The following four types of cursors are available.

- Horizontal cursors
- Vertical cursors
- Marker cursors
- Angle cursors

Limitations

Cursor measurements cannot be made on the following waveforms.

- Snapshot waveforms
- Accumulated waveforms (except the last accumulated waveform)

Cursor Measurement Parameters

The table below shows the parameters that can be measured and displayed using each type of cursors.

When X-Y Waveforms Are Not Displayed**Horizontal cursors**

Measures the Y-axis value at the cursor position.

Y1	Y-axis (vertical axis) value of Cursor1
Y2	Y-axis value of Cursor2
DY	The difference between the Y-axis values of Cursor1 and Cursor2

Vertical cursors

Measures the X-axis and Y-axis values at the cursor position. When measuring logic input waveforms, you can select whether to display the measured values in binary or hexadecimal notation, and the read direction of the bit data.

X1	X-axis (vertical axis) value of Cursor1
X2	X-axis value of Cursor2
DX	The difference between the X-axis values of Cursor1 and Cursor2
1/DX	The inverse of the difference between the X-axis values of Cursor1 and Cursor2
Y1	Y-axis value at the cross point of Cursor1 and the waveform
Y2	Y-axis value at the cross point of Cursor2 and the waveform
DY	The difference between the Y-axis values of Cursor1 and Cursor2

Marker cursors

Measures the X-axis value and Y-axis value of the waveform. Marker cursors move along the waveform. M1 (Marker 1) to M4 (Marker 4) can be set on different waveforms.

X1 to X4	X-axis values of M1 to M4
DX2	The difference between the X-axis values of M1 and M2
DX3	The difference between the X-axis values of M1 and M3
DX4	The difference between the X-axis values of M1 and M4
Y1 to Y4	Y-axis values of M1 to M4
DY2	The difference between the Y-axis values of M1 and M2
DY3	The difference between the Y-axis values of M1 and M3
DY4	The difference between the Y-axis values of M1 and M4

Angle cursors (Degree)

Measurements can be made by converting the time axis values into angles. The zero point (position of reference cursor Ref1) and the end point (position of the reference cursor Ref2) are set on the X-axis and an angle (reference angle) is assigned to the width of Ref1 and Ref2. The positions of the two angle cursors (Cursor1 and Cursor2) are converted into angles from the specified reference angle and measured.

X1	Angle of Cursor1 from Ref1
X2	Angle of Cursor2 from Ref1
DX	The angle difference between Cursor1 and Cursor2
Y1	Y-axis value at the cross point of Cursor1 and the waveform
Y2	Y-axis value at the cross point of Cursor2 and the waveform
DY	The difference between the Y-axis values of Cursor1 and Cursor2
Selectable range of the reference angle	1 to 720°C

10.5 Making Cursor Measurements

When X-Y Waveforms Are Displayed

Horizontal cursor: Measures the Y-axis value at the cursor position.

Y1	Y-axis value of Cursor1
Y2	Y-axis value of Cursor2
DY	The difference between the Y-axis values of Cursor1 and Cursor2

Vertical cursor: Measures the X-axis value at the cursor position.

X1	X-axis value of Cursor1
X2	X-axis value of Cursor2
DX	The difference between the X-axis values of Cursor1 and Cursor2

Marker Cursor: Measures the X-axis value and Y-axis value of the waveform.

T	Time of the cursor from the trigger point
X	X-axis value of the cursor
Y	Y-axis value of the cursor

Movement Range of Cursors

When X-Y Waveforms Are Not Displayed

Horizontal cursors

The movement range is ± 4 divisions. The resolution is 0.01 divisions.

Vertical cursor, marker cursor, and angle cursor

The movement range is ± 5 divisions. The resolution is 10 divisions+the display record length. For a description of the display record length, see appendix 1.

When X-Y Waveforms Are Displayed

Horizontal cursors and vertical cursors

The movement range is ± 4 divisions. The resolution is 0.01 divisions.

Marker Cursors

The movement range is ± 5 divisions. The resolution is 10 divisions+the display record length. For a description of the display record length, see appendix 1.

Display Format of Logic Input (When X-Y Waveforms Are Not Displayed and Only Vertical Cursors Are Used)

When measuring the logic input waveform using vertical cursors, you can set the following items.

Notation System

You can select the notation system used to display measured values.

Binary

Displays values in binary notation.

Hexa

Displays values in hexadecimal notation.

Read Direction of Bit Data

You can select the direction of reading the bit data of the logic input.

A0->A7 B0->B7

Reads the bit data in the direction from bit 0 to bit 7 of Pod A and bit 0 to bit 7 of Pod B.

B7->B0 A7->A0

Reads the bit data in the direction from bit 7 to bit 0 of Pod B and bit 7 to bit 0 of Pod A.

Combining of the Bit Data

The data of Pod A and Pod B can be combined and handled as 16-bit data.

Handling of the OFF Bit

- In binary notation, a dash is displayed at the bit.
- In hexadecimal notation, the value is displayed as though the bit does not exist.

Measurement Example of Logic Input

The values of measurement parameters Y1 and Y2 when the logic input is measured using vertical cursors are as follows.

- **When Pod A or Pod B Is Being Measured by Itself and No OFF Bits Exist**

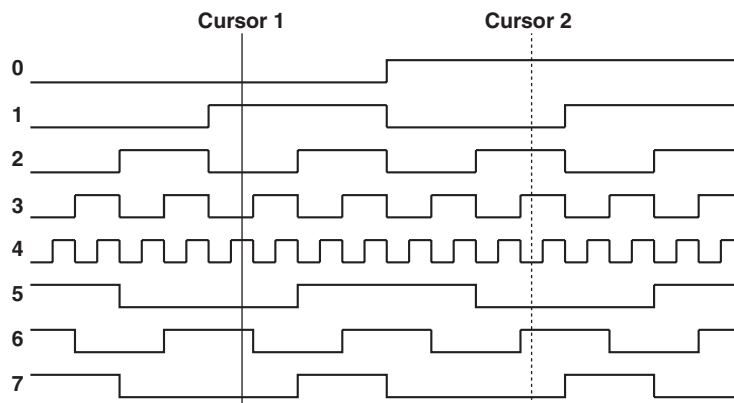

When the read direction of the bit data is A0 -> A7, B0 -> B7

Binary	Y1:01001010	Y2:10110010
Hexa	Y1:4A	Y2:B2

When the read direction of the bit data is B7 -> B0, A7 -> A0

Binary	Y1:01010010	Y2:01001101
Hexa	Y1:52	Y2:4D

- **When Pod A or Pod B Is Being Measured by Itself and OFF Bits Exist**

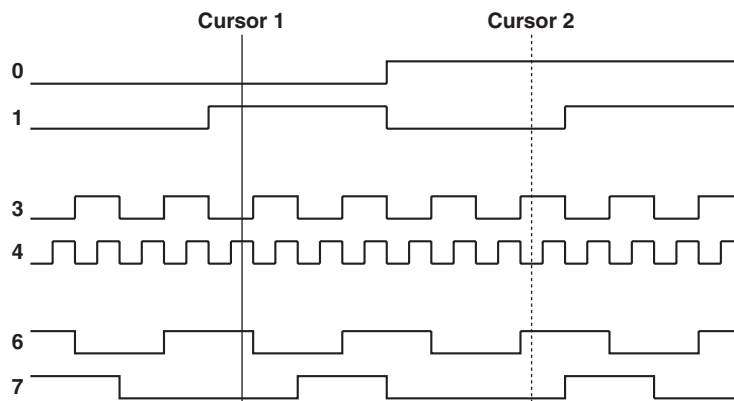

When the read direction of the bit data is A0 -> A7, B0 -> B7

Binary	Y1:01-01-10	Y2:10-10-10
Hexa	Y1:16	Y2:2A

When the read direction of the bit data is B7 -> B0, A7 -> A0

Binary	Y1:01-10-10	Y2:01-01-01
Hexa	Y1:1A	Y2:15

10.5 Making Cursor Measurements

- **When Pod A & Pod B (Combined Data of Pod A and Pod B) Is Being Measured and OFF Bits Exist**

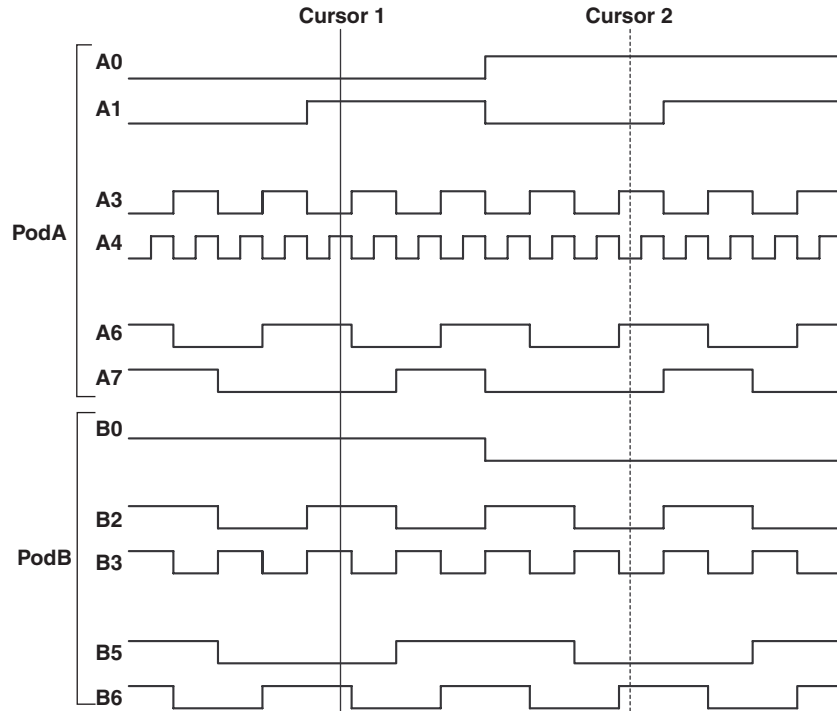

When the read direction of the bit data is A0 -> A7, B0 -> B7
 Binary Y1:01-01-101-11-01 Y2:10-10-100-00-01-
 Hexa Y1:2DD Y2:541

When the read direction of the bit data is B7 -> B0, A7 -> A0
 Binary Y1:-10-11-101-10-10 Y2:-10-00-001-01-01
 Hexa Y1:5DA Y2:415

Jumping the Cursor to the Zoom Waveform Display Frame (When X-Y Waveforms Are Not Displayed)

You can jump M1 to M4 (marker cursors) and Cursor1 and Cursor2 (vertical cursors or angle cursors) to the zoom waveform display frame. The cursors can be jumped in the following manner.

Marker Cursors

to Z1

Make the selected marker jump to the Z1 window.

to Z2

Make the selected marker jump to the Z2 window.

Vertical Cursors and Angle Cursors

Cursor1 to Z1

Make Cursor1 jump to the Z1 window.

Cursor1 to Z2

Make Cursor1 jump to the Z2 window.

Cursor2 to Z1

Make Cursor2 jump to the Z1 window.

Cursor2 to Z2

Make Cursor2 jump to the Z2 window.

Note

- The measured values of the X-axis (horizontal axis and time axis) are displayed relative to the trigger position.
- If measurement is not possible, *** is displayed in the measured value display area.
- Logic waveforms (optional) cannot be selected in horizontal cursor and marker cursor measurements.
- When the T/div setting is not repetitive sampling mode and the acquisition mode is not averaging mode, sampled data may not exist at the vertical cursor position in the interpolation display¹ area. The measured value of the vertical cursor in this case is the value of the sampled data closest to the cursor on the right. On the contrary, marker cursors always move over the sampled data.

¹ Interpolation display is used when there are less than 500 points of sampled data in 10 divisions along the X-axis or when the zoom waveform display format is Main&Z1&Z2 and there are less than 250 points of sampled data in the zoom waveform display frame.

10.6 Automated Measurement of Waveform Parameters

<For a description of this function, refer to page 2-30.>

Procedure

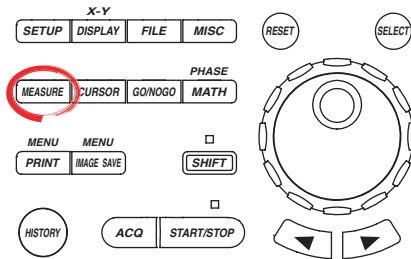

- To exit the menu during operation, press **ESC** located above the soft keys.
- In the procedural explanation below, the term *jog shuttle & SELECT* refers to the operation of selecting/setting items and entering values using the *jog shuttle* and **SELECT** and **RESET** keys. For details on this operation, see sections 4.1 or 4.2.
- For a description of the operation using a USB keyboard or a USB mouse, see section 4.3.

1. Press **MEASURE**. The MEASURE menu appears.
2. Press the **Mode** soft key. The Mode menu appears.
3. Press the **ON** soft key.

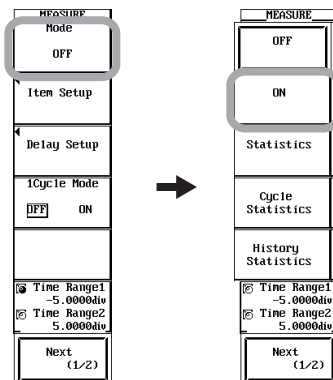

Selecting the Measurement Parameters

4. Press the **Item Setup** soft key. The Item Setup menu and Item Setup dialog box appear.
5. Press the **CH1 to CH8/4, Math1, or Math2** soft key to select the waveform to be measured.
 - On the DL7440, select CH1 to CH4, Math1, or Math2.
 - On the DL7480, select CH1 to CH8, Math1, or Math2. CH6, CH7, CH8, Math1, and Math2 appear when you press the To Page 2 soft key.
6. Turn the **jog shuttle** to select the parameter to be measured.
7. Press **SELECT**. The mark to the left of the measurement parameter is highlighted.
 - The measurement parameter whose mark to the left of the parameter is highlighted is the parameter to be measured.
 - If you execute All Clear using **jog shuttle & SELECT**, all the highlighted displays are cleared, and all parameters are not measured.
 - If you execute Copy To All Trace using **jog shuttle & SELECT**, the settings in the current Item Setup dialog box are copied to the Item Setup dialog boxes of all waveforms.
8. Press **ESC**. The Item Setup dialog box closes.

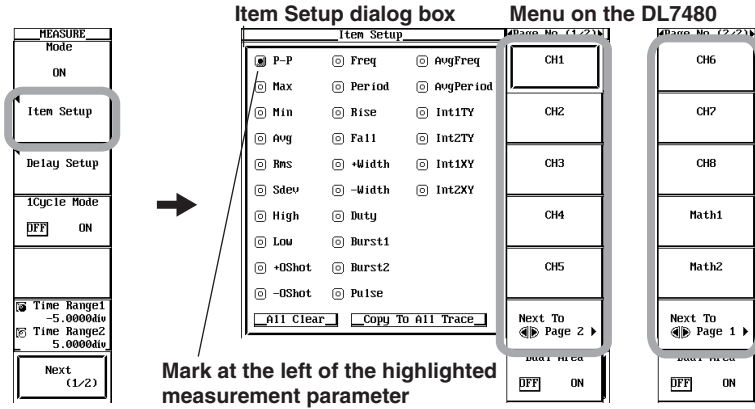

Setting the Delay Measurement between Waveforms

9. Press the **Delay Setup** soft key. The Delay Setup dialog box opens.

Setting the Measurement Mode and Detection Conditions of the Waveform to Be Measured

10. Use **jog shuttle & SELECT** to select the measurement mode (Mode box).
11. Press the **CH1 to CH8/4, Math1, or Math2** soft key to select the waveform to be measured.
 - On the DL7440, select CH1 to CH4, Math1, or Math2.
 - On the DL7480, select CH1 to CH8, Math1, or Math2. CH7, CH8, Math1, and Math2 appear when you press the To Page 2 soft key.
12. Use **jog shuttle & SELECT** to select which slope edge, rising or falling, of the waveform being measured is to be detected (Polarity box under Measure).
13. Use **jog shuttle & SELECT** to set the edge detection count (the edge count to which delay is measured, Edge Count box under Measure).

Setting the Reference Point

14. Use **jog shuttle & SELECT** to select the reference point (Reference box).
If you select Trig for the reference point, the succeeding steps are not necessary.
15. Use **jog shuttle & SELECT** to select the reference waveform (Trace box under Reference).
16. Use **jog shuttle & SELECT** to select which slope edge, rising or falling, of the reference waveform to be the reference (Polarity box under Reference).
17. Use **jog shuttle & SELECT** to set the edge detection count (the edge count to be the reference point, Edge Count box under Reference).
18. Press **ESC**. The Delay Setup dialog box closes.

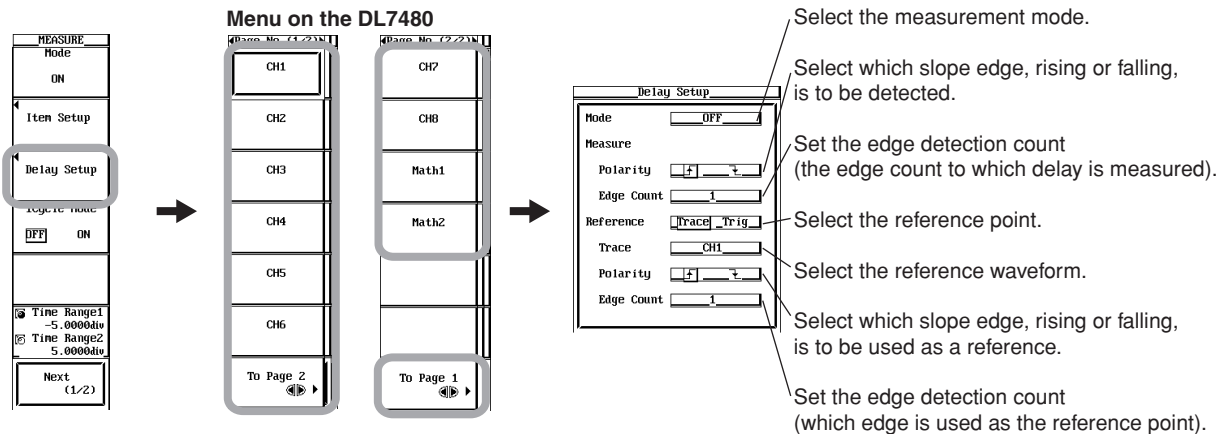

Turning ON/OFF 1 Cycle Mode

19. Press the **1Cycle Mode** soft key to select ON or OFF.

Setting the Measurement Range

20. Press the **Time Range1/Time Range2** soft key to set the jog shuttle control to Time Range1, Time Range2, or both Time Range1 and Time Range 2.
 - If you select Time Range1, you can move Time Range1.
 - If you select Time Range2, you can move Time Range2.
 - If you select both Time Range1 and Time Range2, you can move Time Range1 and Time Range2 horizontally without changing the spacing between the two. The value of the digit being specified by Time Range1 changes.
21. Turn the **jog shuttle** to set the measurement range.

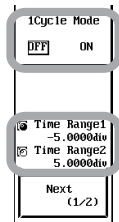

Setting Distal, Mesial, and Proximal Values

22. Press the **Next (1/2)** soft key. The page 2 menu appears.

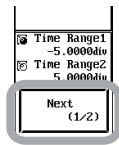

Selecting the Waveform to Be Set

23. Press the **Trace** soft key. The Trace menu appears.
24. Press the **CH1 to CH8/4, Math1, or Math2** soft key to select the waveform to be set.
 - On the DL7440, select CH1 to CH4, Math1, or Math2.
 - On the DL7480, select CH1 to CH8, Math1, or Math2. CH7, CH8, Math1, and Math2 appear when you press the To Page 2 soft key.

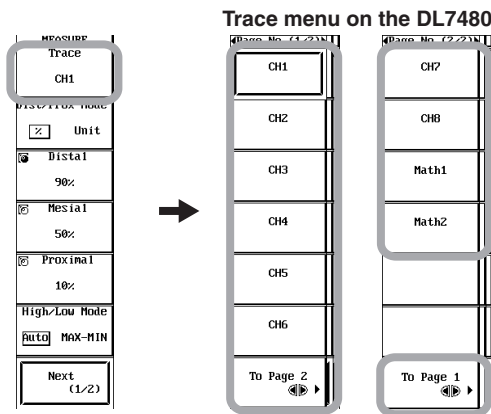

Setting Distal, Mesial, and Proximal Unit and Values

25. Press the **Dist/Prox Mode** soft key to select % or Unit.
 - If you select %, you can set the distal, mesial, and proximal values in percentages by taking the high level and low level of the waveform to be set to be 100% and 0%, respectively.
 - If you select Unit, you can set the distal, mesial, and proximal values in the range corresponding to V/div×8 divisions within the screen.
26. Press the **Distal** soft key.
27. Turn the **jog shuttle** to set the distal value.
28. Press the **Mesial** soft key.
29. Turn the **jog shuttle** to set the mesial value.
30. Press the **Proximal** soft key.
31. Turn the **jog shuttle** to set the proximal value.

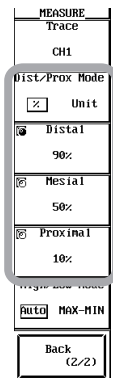

Setting the High and Low Values

32. Press the **High/Low Mode** soft key to select Auto or MAX-MIN.
 - If you select Auto, the higher amplitude level is set to high and lower level is set to low by taking into account the frequency of occurrence of the voltage level of the waveform being measured within the measurement range and the effects of ringing and spikes.
 - If you select MAX-MIN, the maximum value (MAX) and minimum value (MIN) within the range are set to high and low values, respectively.

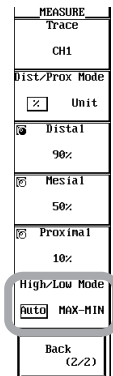

10.6 Automated Measurement of Waveform Parameters

Explanation

This section explains the setup procedures for performing automated measurement on various measurement parameters on the displayed waveform (within the display record length, see appendix 1). Up to 24000 data points of the results of automated measurements can be saved to a file (see section 12.10).

Limitations

Automated measurement of waveform parameters cannot be performed on the following waveforms.

- Snapshot waveforms
- Accumulated waveforms (except the last accumulated waveform)
- Logic input waveforms

Automated Measurement Mode

The following modes are available in automated measurement of waveform parameters.

OFF	Automated measurement is not performed.
ON	Measures the specified parameters.
Statistics, Cycle Statistics, and History Statistics	Performs statistical processing on the measured results of the specified parameters. See section 10.7.

Number of Measurement Parameters

Measurements can be made on 26 types of parameters and delay between waveforms. Up to 24000 data points of measurement parameters of all waveforms can be saved.

Number of Parameters That Can Be Displayed

Automated Measurement Mode	Number of Displayed Parameters
ON	Displays up to 12 parameters of all waveforms. The order in which the waveforms are listed is the same as the order in which the waveforms appear in the menu used to select the waveforms to be measured. The order in which the parameters are listed is the same as the order in which the parameters appear in the Item Setup dialog box.
Statistics	Displays up to 2 statistical values of the measurement parameters of all waveforms. The order in which the waveforms and parameters is listed is the same as the ON case.
Cycle Statistics	Same as Statistics.
History Statistics	Same as Statistics.

Voltage-Axis Parameters

P-P:	P-P value (Max – Min) [V]	-OShot:	Amount of undershoot
Max:	Max Voltage [V]	(-vr)*:	$(\text{Low} - \text{Min}) / (\text{High} - \text{Low}) \times 100 [\%]$
Min:	Min Voltage [V]	+OShot:	Amount of overshoot
Rms:	Rms value $(1/\sqrt{n})(\sum(x_i)^2)^{1/2}$ [V]	(+Ovr)*:	$(\text{Max} - \text{High}) / (\text{High} - \text{Low}) \times 100 [\%]$
Avg:	Average voltage $(1/n)\sum x_i$ [V]	High:	High voltage [V]
Sdev:	Standard deviation	Low:	Low voltage [V]
(SDv)*:	$(1/n(\sum x_i^2 - (\sum x_i)^2/n))^{1/2}$		

* The characters inside the parentheses are measurement parameter names used when displaying the measured values.

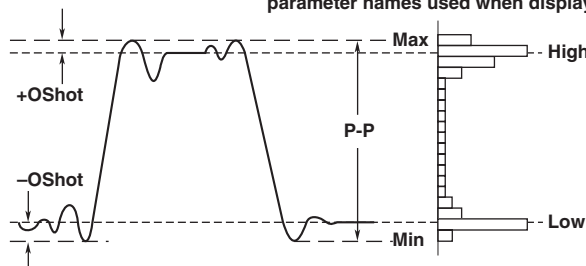

Time-Axis Parameters

Rise:	Rise time [s]	AvgPeriod:	Average period within the measurement range [Hz]
Fall:	Fall time [s]	(PR-A)*	
Freq:	Frequency [Hz] 1/Period	+Width:	Time width above the mesial value [s]
Period:	Period [s]	(+Wd)*	
(Prod)*		-Width:	Time width below the mesial value [s]
AvgFreq:	Average frequency within the measurement range [Hz]	(-Wd)*	
(FR-A)*		Duty:	Duty cycle + Width/Period × 100[%]

* The characters inside the parentheses are measurement parameter names used when displaying the measured values.

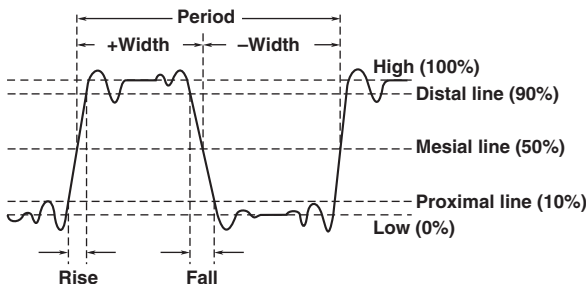

Pulse: Pulse count (PlsN) Set the measurement range (Time Range) according to the pulse you wish to measure.

When Pulse=3

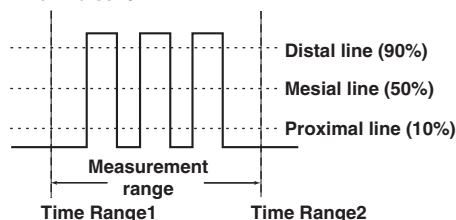

Burst1, Burst2: Burst width [s] (Bst1, Bst2) Set the measurement range (Time Range) according to the burst width you wish to measure.

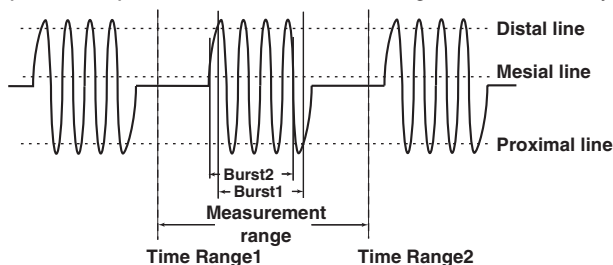

Area Parameters

Int1TY	The area under the positive amplitude
Int2TY	The area under the positive amplitude – the area under the negative amplitude
Int1XY	The summation of the triangular area of the X-Y waveform
Int2XY	The summation of the trapezoidal area of the X-Y waveform

* For details on the derivation of the area, see appendix 2.

Delay between Waveforms

The time difference between the rising or falling edge between waveforms and the time difference from the trigger point to the rising or falling edge of waveforms can be measured.

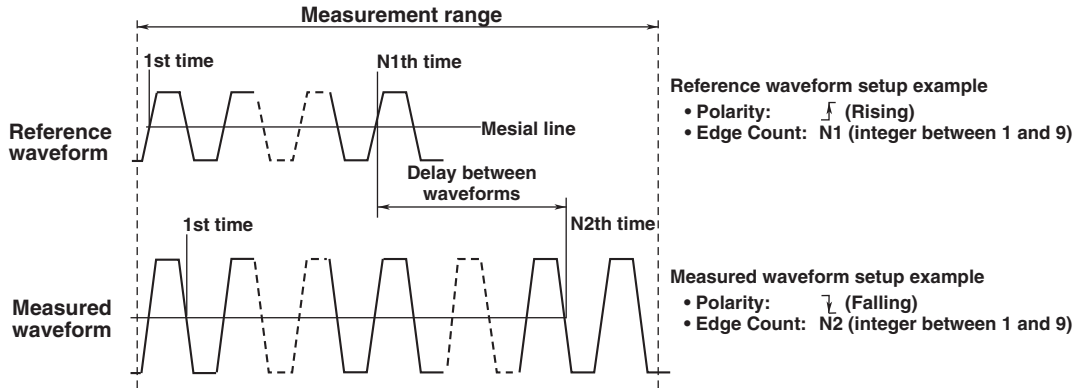

Measurement Mode

You can select the measurement mode.

- OFF
Delay between waveforms is not measured.

- Time
Displays the delay between waveforms using time.

- Degree
Displays the delay between waveforms using angles.
Converting equation $Angle = Delay (s) / Period (s) \times 360 (deg)$. The period is that of a reference waveform.

Reference Point

You can select the reference point used when measuring the delay between waveforms.

- Trace
The reference point is set to the edge of the reference waveform.

- Trig
The reference point is set to the trigger position.

Slope

You can select which slope, rising or falling, of the waveform to be measured or reference waveform is to be detected.

- [rising edge symbol] Rising slope

- [falling edge symbol] Falling slope

Detection Count

Set which edge (count) is to be the reference point or measurement point. The selectable range is an integer from 1 to 9.

- The level at the detection point is the mesial point.
- The measurement parameter name when displaying the measured value is Dly.

1 Cycle Mode

This mode is used determine the waveform cycle and calculate measurement values related to the vertical axis or area within the cycle. This mode is suited to measurement parameters such as Rms and Avg that produce errors depending on the measurement range. This mode does not affect the measurement parameters related to the time axis or the area of the X-Y waveforms.

Measurement Range

The selectable range is ± 5 divisions, and the resolution is 10 divisions=the display record length. The right end of the measurement range (Time Range2) must be greater than or equal to the left end of the measurement range (Time Range1).

Distal, Mesial, and Proximal Values

You can select the method of assigning the three levels that are used as references in measurements such as the rise and fall times. The distal value must be greater than or equal to the mesial value, and the proximal value must be greater than or equal to the mesial value.

%

Taking the high and low levels to be 100% and 0%, respectively, you can set the distal, mesial, and proximal values of each waveform in the range of 0% to 100%. The resolution is 1%.

Unit

You can set the distal, mesial, and proximal values of each waveform in the range corresponding to $V/div \times 8$ divisions within the screen. The resolution is 0.01 divisions.

Method of Setting High and Low

High indicates the 100% level in measurements such as the rise or fall time. And, Low indicates the 0% level. You can select the method for setting High and Low.

Auto

The higher amplitude level is set to high and lower level is set to low by taking into account the frequency of occurrence of the voltage level of the waveform being measured within the measurement range and the effects of ringing and spikes. This method is best-suited when measuring rectangular waveforms and pulse waveforms.

MAX-MIN

The maximum value (MAX) and the minimum value (MIN) in the measurement range are set to high and low values, respectively. This method is best-suited when measuring sine waveforms, ramp waveforms, etc. It is not suited for measuring waveforms with ringing and spikes.

Note

-
- If measurement is not possible, *** is displayed in the measured value display area.
 - If the measurement mode is Degree and the reference point is Trig, *** is displayed in the measured value display area.
 - Automated measurement cannot be performed on the logic input waveform (optional).
 - For waveforms of small amplitude, correct measurements may not be possible.
 - If there are two or more periods of waveform in the measurement range, the measurement of Rise, Fall, Freq, Period, +Width, -Width, and Duty is performed on the first period.
-

10.7 Performing Statistical Processing of the Measured Values of Waveform Parameters

<For a description of this function, refer to page 2-30.>

Procedure

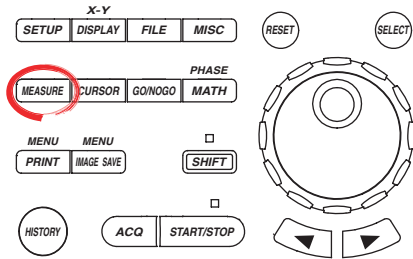

- To exit the menu during operation, press **ESC** located above the soft keys.
- For a description of the operation using a USB keyboard or a USB mouse, see section 4.3.

1. Press **MEASURE**. The MEASURE menu appears.
2. Press the **Mode** soft key. The Mode menu appears.

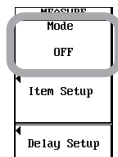

Measuring Waveform Parameters and Performing Statistical Processing (Normal Statistical Processing)

3. Press the **Statistics** soft key. The waveforms are measured and statistical processing is performed. Then, statistics are displayed.

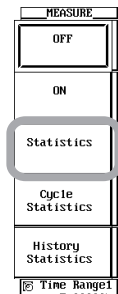

Display example of statistics

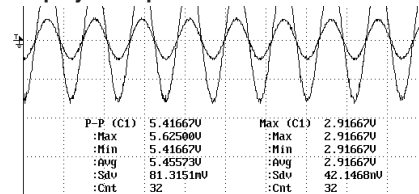

4. Perform the following setup procedures as necessary. For the operating procedure, see section 10.6.
 - Selecting the measurement parameters (steps 4 to 8 on page 10-46).
 - Setting the delay measurement between waveforms (steps 9 to 18 on page 10-47).
 - Turning ON/OFF 1 cycle mode (step 19 on page 10-48).
 - Setting the measurement range (steps 20 and 21 on page 10-48).
 - Setting distal, mesial, and proximal values (steps 22 to 31 on page 10-48).
 - Setting high and low values (step 32 on page 10-49).

Performing Measurement per Cycle and Statistical Processing within the Measurement Range

3. Press the **Cycle Statistics** soft key.

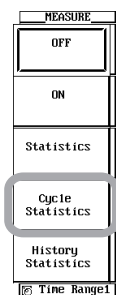

4. Perform the following setup procedures as necessary. For the operating procedure, see section 10.6.
 - Selecting the measurement parameters (steps 4 to 8 on page 10-46).
 - Setting the measurement range (steps 20 and 21 on page 10-48).
 - Setting distal, mesial, and proximal values (steps 22 to 31 on page 10-48).
 - Setting high and low values (step 32 on page 10-49).

Selecting the Waveform Used to Determine the Cycle

5. Press the **Cycle Trace** soft key. The Cycle Trace menu appears.
6. Press the **Own, CH1 to CH8(4), Math1, or Math2** soft key to select the waveform used to determine the cycle.
 - On the DL7440, you can select from Own, CH1 to CH4, Math1, and Math2.
 - On the DL7480, you can select from Own, CH1 to CH8, Math1, and Math2. CH6, CH7, CH8, Math1, and Math2 appear when you press the To Page 2 soft key.

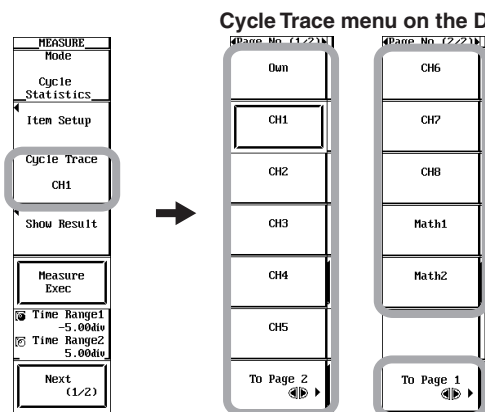

Executing/Aborting Measurement per Cycle and Statistical Processing within the Measurement Range

7. Press the **START/STOP** key to stop waveform acquisition.
8. Press the **Measure Exec** soft key. Measurement per cycle and statistical processing within the measurement range are performed on the displayed waveform from the left end to the right end of the screen (from the oldest waveform). The words Measure Exec change to Measure Abort. To abort the measurement and statistical processing, press the Measure Abort soft key. The measurement and statistical processing are aborted, and the words Measure Abort change to Measure Exec.

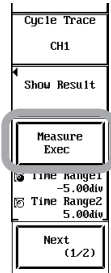

Display example of statistics

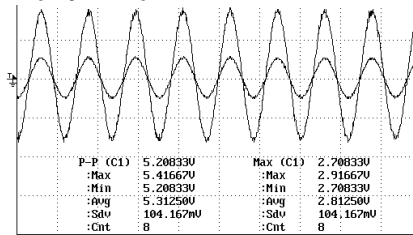

Displaying the Measured Values

9. Press the **Show Result** soft key. The Measure Parameter List window appears and the measured values are listed.
Measured values with assigned numbers #00001, #00002, and so on are displayed in the measured order. The smallest assigned number corresponds to the measured value of the waveform at the left end of the screen (oldest waveform).

Scroll the List

10. Turn the **jog shuttle** to scroll the list up and down.
The Measure Parameter List window displays up to 25 measured values at once in the order of occurrence. By scrolling the list up and down using the jog shuttle, measured values beyond 25 data points can be displayed.
11. Press the **<** or **>** key (arrow key) to scroll the list left and right.
The Measure Parameter List window displays up to 4 measurement parameters at once in the order of parameters that are specified to be measured in the Item Setup dialog box (see page 10-47).
By scrolling the list left and right using **<** and **>**, measured parameters beyond 4 parameters can be displayed.

Measure Parameter List window

Scroll left and right using **<** or **>**.

Measurement parameters

	P-P (C1)	Max (C1)	Min (C1)	Avg (C1)	Utility
#00001	5.20833U	2.70833U	-2.50000U	167.726mU	Max/Min Item1
#00002	5.41667U	2.91667U	-2.50000U	155.812mU	Max/Min Item2
#00003	5.41667U	2.91667U	-2.50000U	159.042mU	Max/Min Item3
#00004	5.41667U	2.91667U	-2.50000U	157.563mU	Max/Min Item4
#00005	5.41667U	2.91667U	-2.50000U	156.695mU	
#00006	5.20833U	2.70833U	-2.50000U	140.670mU	
#00007	5.20833U	2.70833U	-2.50000U	133.681mU	
#00008	5.20833U	2.70833U	-2.50000U	158.046mU	

Sort
FWD REV

Searching the Maximum or Minimum Values of the Four Measurement Parameters Being Displayed

12. Press the **Max/Min Item1** soft key. The measured values of the 1st measurement parameter from the left of the list are searched, and the cursor (highlight) moves to the measured value with the maximum or minimum mark (↑ or ↓).
13. Press the **Max/Min Item2** soft key. The measured values of the 2nd measurement parameter from the left of the list are searched, and the cursor moves to the measured value with the maximum or minimum mark (↑ or ↓).
14. Likewise, press the **Max/Min Item3** and **Max/Min Item4** soft keys. The cursor moves to the corresponding measured values.
The cursor does not move if there is no maximum or minimum value.

	Item1	Item2	Item3	Item4	
Measure Parameter List					
#00001	P-P (C1)	Max (C1)	Min (C1)	Avg (C1)	Max/Min Item1
#00002	↓ 5.20833V	↑ 2.70833V	-2.50000V	↑ 167.726mV	
#00003	↑ 5.41667V	↑ 2.91667V	-2.50000V	155.812mV	Max/Min Item2
#00004	5.41667V	2.91667V	-2.50000V	159.842mV	
#00005	5.41667V	2.91667V	-2.50000V	157.563mV	Max/Min Item3
#00006	5.41667V	2.91667V	-2.50000V	156.695mV	
#00007	5.20833V	2.70833V	-2.50000V	148.679mV	Max/Min Item4
#00008	5.20833V	2.70833V	-2.50000V	↓ 133.681mV	
#00009	5.20833V	2.70833V	-2.50000V	158.046mV	
Sort					
FWD REV					

Mark indicating the minimum value
Mark indicating the maximum value

Sorting the Measured Values in Ascending or Descending Order

15. Press the **Sort** soft key to select FWD or REV.

If FWD is selected, the measured values are sorted in ascending order (left to right on the screen).

	Item1	Item2	Item3	Item4	Utility
Measure Parameter List					
#00001	P-P (C1)	Max (C1)	Min (C1)	Avg (C1)	Max/Min Item1
#00002	↓ 5.20833V	↑ 2.70833V	-2.50000V	↑ 167.726mV	
#00003	↑ 5.41667V	↑ 2.91667V	-2.50000V	155.812mV	Max/Min Item2
#00004	5.41667V	2.91667V	-2.50000V	159.842mV	
#00005	5.41667V	2.91667V	-2.50000V	157.563mV	Max/Min Item3
#00006	5.41667V	2.91667V	-2.50000V	156.695mV	
#00007	5.20833V	2.70833V	-2.50000V	↓ 133.681mV	Max/Min Item4
#00008	5.20833V	2.70833V	-2.50000V	158.046mV	
Sort					
FWD REV					

If REV is selected, the measured values are sorted in descending order (right to left on the screen).

	Item1	Item2	Item3	Item4	Utility
Measure Parameter List					
#00008	P-P (C1)	Max (C1)	Min (C1)	Avg (C1)	Max/Min Item1
#00007	5.20833V	2.70833V	-2.50000V	158.046mV	
#00006	5.20833V	2.70833V	-2.50000V	↓ 133.681mV	Max/Min Item2
#00005	5.41667V	2.91667V	-2.50000V	148.679mV	
#00004	5.41667V	2.91667V	-2.50000V	156.695mV	Max/Min Item3
#00003	5.41667V	2.91667V	-2.50000V	159.842mV	
#00002	↑ 5.41667V	↑ 2.91667V	-2.50000V	155.812mV	Max/Min Item4
#00001	↓ 5.20833V	↓ 2.70833V	-2.50000V	↑ 167.726mV	
Sort					
FWD REV					

Performing Measurement and Statistical Processing of History Waveforms

- Press the **History Statistics** soft key.

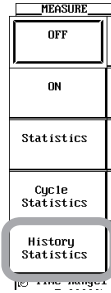

- Perform the following setup procedures as necessary. For the operating procedure, see section 10.6.
 - Selecting the measurement parameters (steps 4 to 8 on page 10-46).
 - Setting the delay measurement between waveforms (steps 9 to 18 on page 10-47).
 - Setting the measurement range (steps 20 and 21 on page 10-48).
 - Setting distal, mesial, and proximal values (steps 22 to 31 on page 10-48).
 - Setting high and low values (step 32 on page 10-49).

Executing/Aborting Measurement and Statistical Processing of History Waveforms

- Press the **START/STOP** key to stop waveform acquisition.
- Press the **Measure Exec** soft key. Measurement and statistical processing are executed on the history waveforms. The words Measure Exec change to Measure Abort. To abort the measurement and statistical processing, press the Measure Abort soft key. The measurement and statistical processing are aborted, and the words Measure Abort change to Measure Exec.

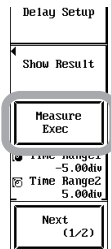

Display example of statistics

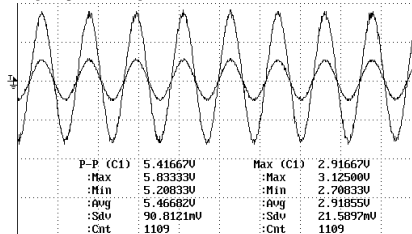

Displaying the Measured Values

- The procedure is the same as steps 9 to 15 on pages 10-56 and 10-57.

Display example of measured values

Measure Parameter List				Utility	
	P-P (C1)	Max (C1)	Min (C1)	Avg (C1)	
#0001	5.62500V	2.91667V	1-2.70833V	143.666mV	Max/Min Item1
#0002	5.41667V	2.91667V	1-2.50000V	147.353mV	
#0003	5.41667V	2.91667V	-2.50000V	148.601mV	Max/Min Item2
#0004	5.62500V	2.91667V	-2.50000V	149.010mV	
#0005	5.41667V	2.91667V	-2.50000V	147.977mV	
#0006	5.62500V	2.91667V	-2.70833V	145.063mV	
#0007	5.41667V	2.91667V	-2.50000V	147.561mV	
#0008	5.41667V	2.91667V	-2.50000V	157.551mV	Max/Min Item3
#0009	5.41667V	2.91667V	-2.50000V	133.200mV	
#0010	5.62500V	2.91667V	-2.70833V	143.815mV	
#0011	5.41667V	2.91667V	-2.50000V	158.800mV	
#0012	5.62500V	2.91667V	-2.70833V	136.322mV	Max/Min Item4
#0013	5.62500V	2.91667V	-2.70833V	141.317mV	
#0014	5.41667V	2.91667V	-2.50000V	155.261mV	
#0015	5.41667V	2.91667V	-2.50000V	145.896mV	
#0016	5.41667V	2.91667V	-2.50000V	142.150mV	
#0017	5.41667V	2.91667V	-2.50000V	146.520mV	
#0018	5.41667V	2.91667V	-2.50000V	155.470mV	
#0019	5.62500V	2.91667V	-2.70833V	127.997mV	
#0020	5.41667V	2.91667V	-2.50000V	147.377mV	
#0021	5.41667V	2.91667V	-2.50000V	154.845mV	
#0022	5.41667V	2.91667V	-2.50000V	136.530mV	
#0023	5.41667V	2.91667V	-2.50000V	130.911mV	Sort
#0024	5.41667V	2.91667V	-2.50000V	144.439mV	
#0025	5.41667V	2.91667V	-2.50000V	142.566mV	FWD REV

Explanation

This section explains the setup procedures for performing measurement and statistical processing on the same measurement parameters as the automated measurement of waveform parameters. The following five statistics can be displayed on the measured values of two measurement parameters.

Max	Maximum value
Min	Minimum value
Avg	Average value
Sdv	Standard deviation
Cnt	Number of measured values used in the statistical processing

For example, if you selected P-P of CH1 as a measurement parameter, the maximum, minimum, average, standard deviation, and the number of measured values used in the statistical processing of the P-P of CH1 are displayed.

Target Waveform

The waveform on which measurement and statistical processing are performed is CH1 to CH8/4*, Math1, or Math2. Statistical processing is performed on the measurement target waveform that was selected in section 10.6.

* On the DL7440, the waveform is CH1 to CH4, Math1, or Math2. On the DL7480, the waveform is CH1 to CH8, Math1, or Math2.

Measurement Parameters on Which Statistical Processing Is Performed

- Measurement and statistical processing can be performed on the same measurement parameters as those of the automated measurement of waveform parameters.
- In the normal measurement and statistical processing and the measurement and statistical processing of history waveforms, statistical processing can be performed on the computed parameters of the automated measurement of waveform parameters on dual areas.
- The statistics that can be displayed are two parameters of the selected measurement parameters (see page 10-46) in either type of measurement and statistical processing. If you selected three or more measurement parameters, the first two parameters in the order of parameters that are specified to be measured (P-P, Max, Min, ... , Init1XY, and Init2XY) in the Item Setup dialog box (see page 10-47) from the smallest channel are displayed. For example, if you selected P-P of CH1, Min of CH2, and Max of CH3, P-P of CH1 and Min of CH2 are displayed. The statistics that are not displayed can be loaded into a PC using the communication function. For details, see the *Communication Interface User's Manual (IM701450-17E)*.

Measurement Range

The measurement range is the same as the measurement range specified in the automated measurement of waveform parameters. See section 10.6 or 10.8.

Methods of Measurement and Statistical Processing

The following three types of measurement and statistical processing are available.

Normal Measurement and Statistical Processing

Measurement and statistical processing of the selected measurement parameters are performed on all acquired waveforms while acquiring waveforms.

- If you stop waveform acquisition and start it again, measurement and statistical processing continues from where it left off.
- Measurement and statistical processing are performed on the selected measurement parameters that are not displayed. Therefore, if you disable the measurement and statistical processing of a displayed measurement parameter while waveform acquisition is in progress, the statistics of the next selected measurement parameter in line to be displayed are displayed. The number of measured values used in the measurement and statistical processing (Cnt) is the number of measured values measured up to that point.
- If you add measurement and statistical processing on a new measurement parameter while waveform acquisition is in progress or when it is stopped, the number of measured values used in the measurement and statistical processing (Cnt) is the number of measured values measured since the parameter was added.

10.7 Performing Statistical Processing of the Measured Values of Waveform Parameters

Measurement per Cycle and Statistical Processing within the Measurement Range

The cycle of the displayed waveform is determined in order from the oldest data, the selected parameters for automated measurement are measured on the data within the cycle, and statistical processing is performed. The cycle is determined in the same fashion as the Period for the waveform parameter. You can select whether to apply the cycle of the specified waveform to all waveforms or determine the cycle for each waveform. Measurement and statistical processing can be performed on a single history waveform selected by Select Record. For the procedure of selecting history waveforms, see section 10.1.

CH1 to CH8 (4), Math1, Math2

Performs automated measurement of waveform parameters on all target waveforms per cycle of the specified channel, and performs statistical processing. You can select up to channel CH4 and CH8 on the DL7440 and DL7480, respectively.

Own

Determines the cycle for each target waveform, performs automated measurement of waveform parameters for each cycle, and performs statistical processing. However, if signals of different cycles are applied to multiple channels, automated measurement of waveform parameters and statistical processing are performed for the number of cycles of the channel whose cycle is the slowest on all other channels.

-
- The following parameters cannot be measured.

Waveform Used to Determine the Cycle

(If you selected "Own" for the method of determining the cycle described earlier, all the waveforms are "waveforms used to determine the cycle"). Avg Freq (average frequency), Avg Period (average period), Pulse (pulse count), Int1XY (area), Int2XY (area), and Delay.

Other Waveforms

Int1XY (area), Int2XY (area), and Delay.

- Cannot be used simultaneously with 1 cycle mode (see page 10-52).

Measurement and Statistical Processing of History Waveforms

Measurement and statistical processing of the selected parameters are performed on the history waveform. Measurement and statistical processing are performed from the oldest data. The range of the history waveform on which measurement and statistical processing are performed is the waveform displayed on the history map (see section 10.1).

Displaying a List of Measured Values

When measurement per cycle and statistical processing within the measurement range as well as measurement and statistical processing of history waveforms are executed, the measured values of the selected measurement parameters can be listed. Numbers are assigned in order from the left end to the right end of the screen (from the oldest waveform) as #00001, #00002, and so on and the corresponding measured values are displayed.

- The maximum and minimum values of each measurement parameter are displayed using ↑ (maximum) and ↓ (minimum). If there are multiple points that are of the same value, the maximum and minimum values are marked on the oldest of the measured values.
- The maximum number of measured values that can be listed is 24000.
 - If this value is exceeded in the measurement and statistical processing of history waveforms, the most recent 24000 measured values are displayed. If the number of measured values exceed 24000, and the maximum or minimum value resides outside the list display, ↑ (maximum) and ↓ (minimum) are not displayed.
 - In the measurement and statistical processing per cycle, measurement and statistical processing are performed on the 24000 values that can be listed, and measurement and statistical processing are not performed on the rest of the waveform.
- In the list of the measurement and statistical processing of history waveforms, you can select a number using the jog shuttle and press SELECT to display the history waveform of the selected number.
- In the list of the measurement per cycle and statistical processing within the measurement range, you can select a number using the jog shuttle and press SELECT to display the waveform (1 cycle) of the selected number zoomed.

Note

- All soft keys except the "Measure Abort" soft key are disabled while the measurement and statistical processing are in progress.
 - Measurement per cycle and statistical processing within the measurement range are not possible in automated measurement of waveform parameters on dual areas (see section 10.7).
-

10.8 Performing Automated Measurements of Waveform Parameters on Dual Areas

Procedure

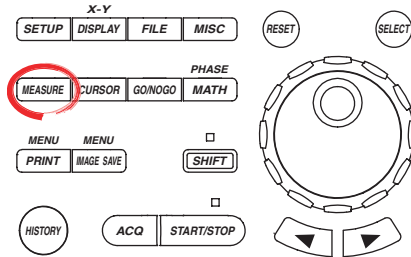

- To exit the menu during operation, press **ESC** located above the soft keys.
- In the procedural explanation below, the term *jog shuttle & SELECT* refers to the operation of selecting/setting items and entering values using the *jog shuttle* and **SELECT** and **RESET** keys. For details on this operation, see sections 4.1 or 4.2.
- For a description of the operation using a USB keyboard or a USB mouse, see section 4.3.

1. Press **MEASURE**. The MEASURE menu appears.
2. Press the **Mode** soft key. The Mode menu appears.

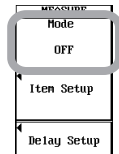

Entering the Menu for the Automated Measurements of Waveform Parameters on Dual Areas

3. Press the **ON**, **Statistics**, or **History Statistics** soft key.

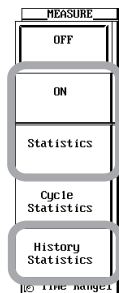

4. Press the **Item Setup** soft key. The Item Setup menu and Item Setup dialog box appear.
5. Press the **Dual Area** soft key to select ON. The Dual Area menu appears.
6. Press the **Item Setup** soft key. The Item Setup dialog box opens.

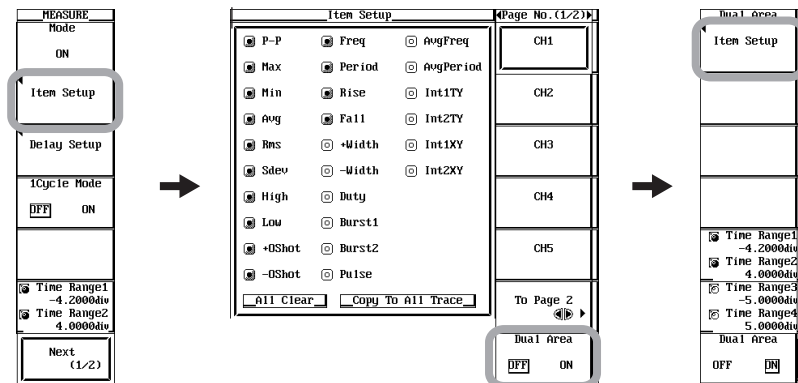

Setting the Computation Parameters

7. Use **jog shuttle & SELECT** to set the following items of computation parameter User1.
 - Turn ON/OFF the computation parameter display (Mode box).
 - Select the first measurement target waveform or constant from CH1 to CH8/4*, Math1, Math2, None or Const1 to Const4 (Trace box of Area1).
 - Select the first measurement parameter (Item box of Area1).
 - Select the operator from +, -, *, and / (Ope box).
 - Select the second measurement target waveform or constant from CH1 to CH8/4*, Math1, Math2, None or Const1 to Const4 (Trace box of Area2).
 - Select the second measurement parameter (Item box of Area2).
 - Set the unit (Unit box) as necessary.

* On the DL7440, you can select from CH1 to CH4, Math1, Math2, None or Const1 to Const4. On the DL7480, you can select from CH1 to CH8, Math1, Math2, None or Const1 to Const4.
8. Repeat step 7 to set computation parameter User2 to User4.
9. Use **jog shuttle & SELECT** to set constants Const1 to Const4.

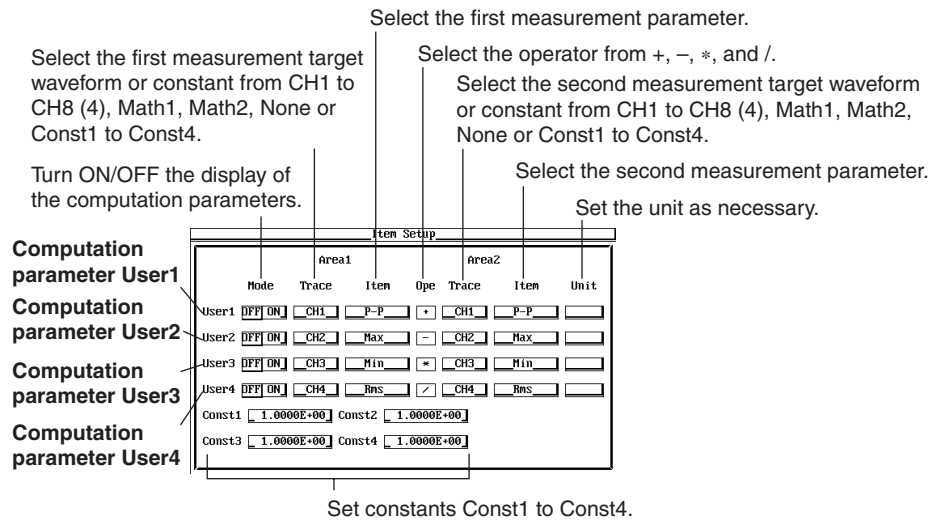

10. Press **ESC**. The Item Setup dialog box closes.

Setting the Measurement Range Area1 of the First Measurement Parameter

11. Press the **Time Range1/Time Range2** soft key to set the jog shuttle control to Time Range1, Time Range2, or both Time Range1 and Time Range 2.
 - If you select Time Range1, you can move Time Range1.
 - If you select Time Range2, you can move Time Range2.
 - If you select both Time Range1 and Time Range2, you can move Time Range1 and Time Range2 horizontally without changing the spacing between the two. The value of the digit being specified by Time Range1 changes.
12. Turn the **jog shuttle** to set the measurement range Area1.

Setting the Measurement Range Area2 of the Second Measurement Parameter

13. Press the **Time Range3/Time Range4** soft key to set the jog shuttle control to Time Range3, Time Range4, or both Time Range3 and Time Range 4.
 - If you select Time Range3, you can move Time Range3.
 - If you select Time Range4, you can move Time Range4.
 - If you select both Time Range3 and Time Range4, you can move Time Range3 and Time Range4 horizontally without changing the spacing between the two. The value of the digit being specified by Time Range3 changes.

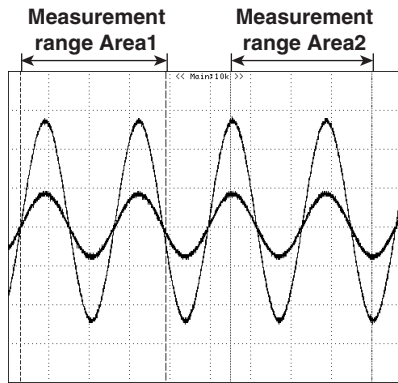

14. Turn the **jog shuttle** to set the measurement range Area2.

Setting the Distal, Mesial, and Proximal Values and High and Low Values

15. The procedure is the same as steps 22 to 32 on pages 10-48 and 10-49.

Explanation

This section explains the setup procedures for performing automated measurement of various measurement parameters (waveform parameters) on dual areas simultaneously or performing computation using the measured values on the displayed waveform (within the display record length, see appendix 1).

Limitations

Automated measurement of waveform parameters cannot be performed on the following waveforms.

- Snapshot waveforms.
- Accumulated waveforms (however, measurement is possible on the accumulated waveform acquired last).
- Logic input waveforms.

Automated Measurement Mode

The following modes are available in automated measurement of waveform parameters. To perform automated measurement of waveform parameters on dual areas, select ON, Statistics, or History Statistics mode.

OFF

Automated measurement is not performed.

ON

Measures the specified parameters.

Statistics, Cycle Statistics, and History Statistics

Performs statistical processing on the measured results of the specified parameters. See section 10.7. However, measurement and statistical processing of Cycle Statistics cannot be performed using automated measurement of waveform parameters on dual areas.

Measurement Parameters

26 types of parameters and delay between waveforms can be selected as operands of computation parameters. For details on the measurement parameters, see section 10.6.

Computation Parameters

- Four parameters, User1 to User4, can be computed and displayed.
- Computation can be performed by setting the measurement parameters of the two areas of the measurement target waveform as operands and using operators +, -, *, or /. The results are displayed as computation parameters User1 to User4.

Equations

For example, the equation of computation parameter User1 is as follows:

User1 = M1operatorM2

M1: Measurement parameter of Area 1 of the measurement target waveform

M2: Measurement parameter of Area 2 of the measurement target waveform

Operator: +, -, *, or /

The measurement target waveforms of M1 and M2 can be selected from CH1 to CH8(4)*, Math1, Math2, None or Const1 to Const4.

* On the DL7440, you can select from CH1 to CH4, Math1, Math2, None or Const1 to Const4. On the DL7480, you can select from CH1 to CH8, Math1, Math2, None or Const1 to Const4.

- If one of the measurement target waveform is set to None, the measured value of the other measurement parameter is displayed.
- IF both measurement target waveforms are set to None, the measurement value display area shows ***.

Turning ON/OFF the Computation Parameters

The display of the computation parameters User1 to User4 can be turned ON/OFF separately.

ON	Displays the measurement parameter.
OFF	Does not display the measurement parameter.

Unit of Computation Parameters

Units can be assigned to computation parameters User1 to User4 using up to 4 characters.

- The type of characters that can be used are those displayed on the keyboard.
- The specified unit is displayed when the display of the measurement parameter is turned ON.

Measurement Range

The selectable range is ± 5 divisions, and the resolution is 10 divisions+display record length. The right end of the measurement range (Time Range2) must be greater than or equal to the left end of the measurement range (Time Range1), and the right end of the measurement range (Time Range4) must be greater than or equal to the left end of the measurement range (Time Range3).

- Separate measurement ranges (Area1 and Area2) can be specified for measurement parameter 1 and 2.
- The measurement range of dual areas may overlap.

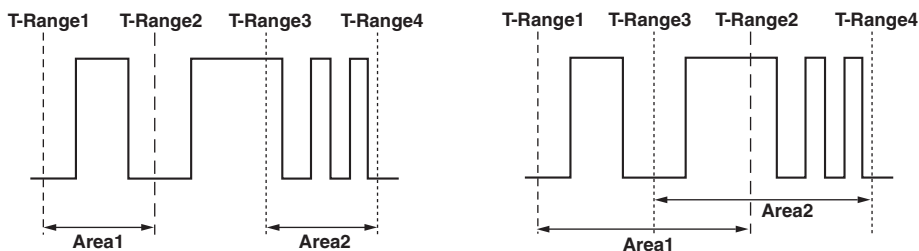

Setting the Distal, Mesial, and Proximal Values and High and Low Values

The procedure is the same as with the normal automated measurement of waveform parameters on a single area. See section 10.6.

Note

- If measurement is not possible, *** is displayed in the measured value display area.
- If the measurement mode is Degree and the reference point is Trig, *** is displayed in the measured value display area.
- Automated measurement cannot be performed on the logic input waveform (optional).
- For waveforms of small amplitude, correct measurements may not be possible.
- If there are two or more periods of waveform in the measurement range, the measurement is performed on the first period.

10.9 Performing GO/NO-GO Determination Using Zones

Procedure

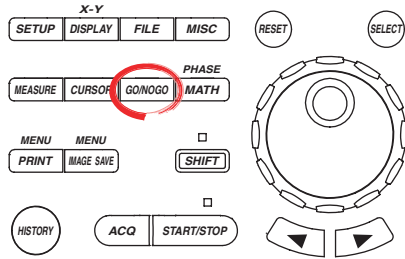

- To exit the menu during operation, press **ESC** located above the soft keys.
- In the procedural explanation below, the term *jog shuttle & SELECT* refers to the operation of selecting/setting items and entering values using the **jog shuttle** and **SELECT** and **RESET** keys. For details on this operation, see sections 4.1 or 4.2.
- For a description of the operation using a USB keyboard or a USB mouse, see section 4.3.

1. Press **GO/NOGO**. The GO/NO-GO menu appears.
2. Press the **Mode** soft key. The Mode menu appears.

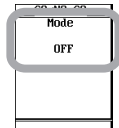

Entering the GO/NO-GO Determination Setup Menu

3. Press the **Zone** soft key. The Zone menu appears.

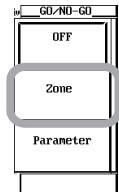

Creating Determination Zones

Stop waveform acquisition after displaying the reference waveform, and then create the zone.

4. Press the **To EditMenu** soft key. The To Edit menu appears.

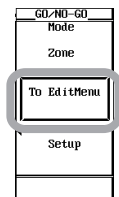

Creating a New Zone

5. Press the **New** soft key. The Trace menu appears.
6. Press the **CH1 to CH8/4**, **Math1**, or **Math2** soft key to select the reference waveform for creating the zone. The Edit menu appears.
 - On the DL7440, select CH1 to CH4, Math1, or Math2.
 - On the DL7480, select CH1 to CH8, Math1, or Math2. CH7, CH8, Math1, and Math2 appear when you press the To Page 2 soft key.

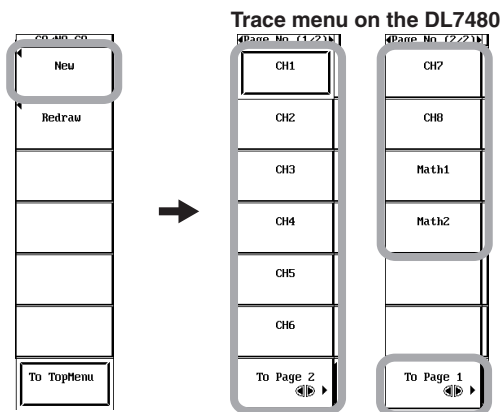

Editing the Entire Zone

7. Press the **Edit** soft key to select Whole.
8. Press the **Upper/Lower** or **Left/Right** soft key to set the jog shuttle control to Upper, Lower, Left, or Right.
 - If you select Upper, you can edit the zone upward with respect to the reference waveform.
 - If you select Lower, you can edit the zone downward with respect to the reference waveform.
 - If you select Left, you can edit the zone toward the left with respect to the reference waveform.
 - If you select Right, you can edit the zone toward the right with respect to the reference waveform.
9. Turn the **jog shuttle** to edit the entire zone.

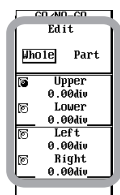

Editing the Partial Zone

10. Press the **Edit** soft key to select Part.
11. Press the **Time Range1/Time Range2** soft key to set the jog shuttle control to Time Range1 or Time Range2.
 - If you select Time Range1, you can move Time Range1.
 - If you select Time Range2, you can move Time Range2.
12. Turn the **jog shuttle** to set the range of the partial zone to be edited.
13. Press the **Upper/Lower** soft key to set the jog shuttle control to Upper or Lower.
 - If you select Upper, you can edit the zone upward with respect to the reference waveform in the range between Time Range1 and Time Range2.
 - If you select Lower, you can edit the zone downward with respect to the reference waveform in the range between Time Range1 and Time Range2.
14. Turn the **jog shuttle** to edit the partial zone.



Registering the Edited Zone

15. Press the **Store as** soft key. The Store as menu appears.
16. Press one of the soft keys from **Zone1** to **Zone6** to select the registration destination.
17. Press the **Store Exec** soft key. The edited zone is registered to the selected destination.

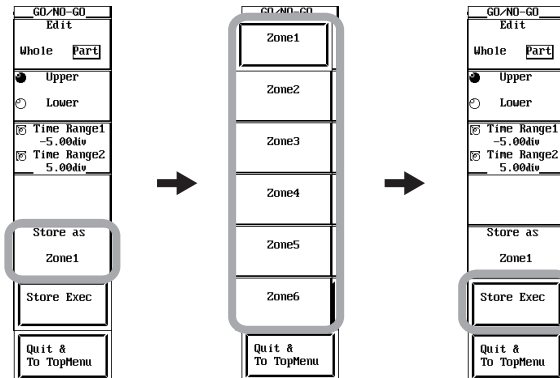

Exiting the Zone Editing

18. Press the **Quit & To TopMenu** soft key. The screen returns to the menu shown in step 3.
 If you press the Quit & To TopMenu soft key without registering the edited zone in steps 15 to 17, the editing up to that point is discarded, and the screen returns to the menu of step 3.

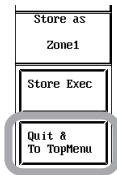

Modifying the Registered Zone

- Turn on the display of the reference waveform that was selected when the zone was created, and then correct the zone.
19. At step 5, press the **Redraw** soft key. A menu for selecting the registered zone appears.
 20. Repeat steps 7 and 18 to modify the registered zone.
 The corrected zone can be registered to a different destination.

Setting the Determination Condition

21. At step 4, press the **Setup** soft key. The Setup dialog box opens.

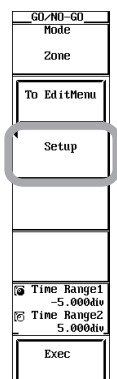

22. Use **jog shuttle & SELECT** to set the following items of determination zone Zone1.
 - Select a determination target waveform of CH1 to CH8/4*, Math1, or Math2 (Trace box).
 - Select whether to perform determination at the corresponding determination zone (ON/OFF) (Mode box).
 - Select whether the waveform exiting the determination zone (OUT) or entering the determination zone (IN) (Condition box).

* On the DL7440, you can select from CH1 to CH4, Math1, and Math2. On the DL7480, you can select from CH1 to CH8, Math1, and Math2.
23. Repeat step 22 to set determination zones Zone2 to Zone6.
24. Use **jog shuttle & SELECT** to set the determination logic to AND or OR (Logic box).
25. Use **jog shuttle & SELECT** to set the determination operation to Single or Continue (Sequence box).
26. Use **jog shuttle & SELECT** to set the waveform acquisition count (ACQ Count box).
27. Use **jog shuttle & SELECT** to set the DL7400 action when the condition is met (Action box).
28. Press **ESC**. The Setup dialog box closes.

Select the determination target waveform from CH1 to CH8 (4), Math1, or Math2.

Select whether to perform determination at the corresponding determination zone (ON/OFF).

Select which condition when the waveform exits the determination zone (OUT) or when the waveform enters the determination zone (IN) is considered true.

Set the determination logic to AND or OR.

Set the determination operation to Single or Continue.

Set the number of waveform acquisitions.

Set the action taken by the DL7400 when the condition is met.

Setting the Determination Range

29. Press the **Time Range1/Time Range2** soft key to set the jog shuttle control to Time Range1, Time Range2, or both Time Range1 and Time Range 2.
 - If you select Time Range1, you can move Time Range1.
 - If you select Time Range2, you can move Time Range2.
 - If you select both Time Range1 and Time Range2, you can move Time Range1 and Time Range2 horizontally without changing the spacing between the two. The value of the digit being specified by Time Range1 changes.

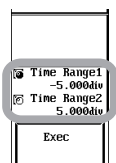

Executing/Aborting Determination

- Press the **Exec** soft key. GO/NO-GO determination is executed. The Exec soft key changes to the Abort soft key. To abort GO/NO-GO determination, press the **Abort** soft key or press **START/STOP**. GO/NO-GO determination is aborted, and the word Abort changes to Exec.

Determination display example

Determination count	Number of times the condition is met
Exe Count: 77	NG Count: 21
Result: X00000	

When all the conditions including the determination logic are met, it is counted as NG (NO-GO).

Displays the determination results of each determination zone in the order Zone1 to Zone6
 (Displays the determination results of determination zones whose Mode is ON)
 O when the conditions of the determination zone are not met
 X when the conditions of the determination zone are met

Explanation

This section explains the setup procedures for creating determination zones based on a reference waveform and performing GO/NO-GO determination on whether the waveform exits or enters the determination zones.

Determination Target Waveform

The waveform on which GO/NO-GO determination is performed is CH1 to CH8/4*, Math1, or Math2.

* On the DL7440, the waveform is CH1 to CH4, Math1, or Math2. On the DL7480, the waveform is CH1 to CH8, Math1, or Math2.

Determination Zones

- The reference waveform for creating the zone is selected from the displayed waveforms, and six determination zones, Zone1 to Zone6, are created and registered. The selectable range of the zone is as follows:

Selectable range in the up and down direction	8 divisions above and below the reference waveform.
Selectable range in the left and right direction	5 divisions to the left and right from the screen center.

- You can select the reference waveform for creating determination zones from CH1 to CH8/4*, Math1, and Math2.
 - * On the DL7440, you can select from CH1 to CH4, Math1, and Math2. On the DL7480, you can select from CH1 to CH8, Math1, and Math2.
- The zone can be edited entirely or partially with respect to the reference waveform.
- Registered zones can be modified.

Determination Condition and DL7400 Action When the Condition Is Met

For each determination zone, you can select the following items.

- Determination target waveform (see "Determination Target Waveform" described above.)
- Enable or disable determination (ON/OFF).
- Whether the waveform exiting the determination zone (OUT) or entering the determination zone (IN) (Condition box) makes the condition true.

Determination Logic

You can select the AND logic or OR logic of the determination conditions of the six determination zones in performing the search.

AND	Condition is considered to be true when all the determination conditions of Zone1 to Zone6 are met.
OR	Condition is considered to be true when any of the determination conditions of Zone1 to Zone6 is met.

Determination Operation

You can select whether to repeat the determination operation.

Single

Performs the determination operation once.

Continue

Repeats the determination operation until the waveform acquisition count (described later) is reached. If the waveform acquisition count is set to Infinite, determination operation repeats until it is aborted.

Waveform Acquisition Count

You can set the number of waveform acquisitions.

Infinite

Continues until waveform acquisition is aborted using the START/STOP key or Abort soft key.

1 to 65536

Waveform acquisition and determination operation stop when the specified number of waveforms are acquired.

DL7400 Action When the Condition Is Met

You can select the action that DL7400 takes when the condition is met. When the condition is met, it is counted as a failure.

Buzzer

Sounds a buzzer.

Save to File

The data is saved to the storage medium specified on the FILE menu (floppy disk or Zip disk, PC card, Net Drive¹, SCSI device², or USB storage).

Hard Copy

Outputs the screen image data to the destination (built-in, USB, or Net Print¹) specified by "Print to" in the PRINT menu.

Image Save

Saves the screen image data to the storage medium (floppy disk, Zip disk, PC card, Net Drive¹, SCSI device², or USB storage) specified in the IMAGE menu.

Send Mail

Sends a mail message¹. Set the number of mail transmission in the range of 1 to 1000. For details, see section 13.5.

1 When the Ethernet interface option is installed

2 When the SCSI interface option is installed

- **Save to File/Hard Copy/Image Save Operation**

The operation follows the settings specified on the FILE, PRINT, or Image Save menu.

- **File Name When Save to File or Image Save Is Specified**

The file is saved using Auto Name under the File menu or the Image Save menu. For details, see section 12.8 or 12.12.

Determination Range

The selectable range is ± 5 divisions, and the resolution is 10 divisions+display record length. The right end of the determination range (Time Range2) must be greater than or equal to the left end of the determination range (Time Range1).

Executing/Aborting GO/NO-GO Determination

- When executed, the determination count (Exe Count), the number of times the condition is met (NG Count), and the determination result of each determination zone are displayed on the screen.
- All keys other than the START/STOP key and the Abort soft key are disabled while determination is in progress.

Note

- When GO/NO-GO determination is executed, the trigger mode is automatically set to Single.
- Determination is not possible when the acquisition mode is set to Average.
- The determination zones that you create are stored as setup data to the storage medium or built-in memory.

10.10 Performing GO/NO-GO Determination Using Measured Waveform Parameters

Procedure

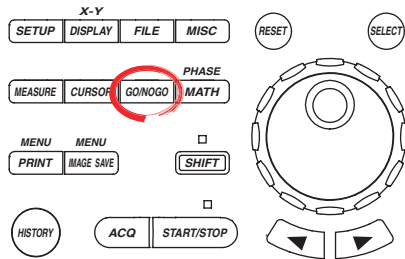

- To exit the menu during operation, press **ESC** located above the soft keys.
- In the procedural explanation below, the term *jog shuttle & SELECT* refers to the operation of selecting/setting items and entering values using the **jog shuttle** and **SELECT** and **RESET** keys. For details on this operation, see sections 4.1 or 4.2.
- For a description of the operation using a USB keyboard or a USB mouse, see section 4.3.

1. Press **GO/NOGO**. The GO/NO-GO menu appears.
2. Press the **Mode** soft key. The Mode menu appears.

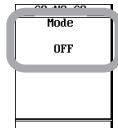

Entering the GO/NO-GO Determination Setup Menu

3. Press the **Parameter** soft key. The Parameter menu appears.

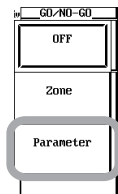

Setting the Determination Condition

4. Press the **Setup** soft key. The Setup dialog box opens.

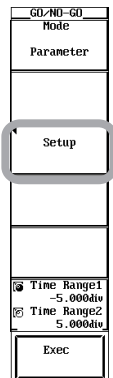

5. Use **jog shuttle & SELECT** to set the following items of determination parameter Param1.
 - Select whether to perform determination using the corresponding determination parameter (ON/OFF) (Mode box).
 - Select a determination target waveform of CH1 to CH8/4*, Math1, or Math2 (Trace box).
 - Select the measurement parameter (Item box).

10.10 Performing GO/NO-GO Determination Using Measured Waveform Parameters

- Set the upper and lower limits used to determine the measured value (Upper and Lower box).
 - Select whether the measured value exiting the range defined by the upper and lower limits (OUT) or entering the range (IN) (Condition box) makes the condition true.
 - * On the DL7440, you can select from CH1 to CH4, Math1, and Math2. On the DL7480, you can select from CH1 to CH8, Math1, and Math2.
6. Repeat step 5 to set determination parameters Param2 to Param4.
 7. Use **jog shuttle & SELECT** to set the determination logic to AND or OR (Logic box).
 8. Use **jog shuttle & SELECT** to set the determination operation to Single or Continue (Sequence box).
 9. Use **jog shuttle & SELECT** to set the waveform acquisition count (ACQ Count box).
 10. Use **jog shuttle & SELECT** to set the DL7400 action when the condition is met (Action box).
 11. Press **ESC**. The Setup dialog box closes.

Determination parameter Param4
Determination parameter Param3
Determination parameter Param2
Determination parameter Param1

Setup

	Param1	Param2	Param3	Param4
Mode	[OFF] [ON]	[OFF] [ON]	[OFF] [ON]	[OFF] [ON]
Trace	[CH1]	[CH1]	[CH1]	[CH1]
Item	[P-P]	[Min]	[Rms]	[Avg]
Upper	[XXX]	[XXX]	[XXX]	[XXX]
Lower	[XXX]	[XXX]	[XXX]	[XXX]
Condition	[OUT] [IN]	[OUT] [IN]	[OUT] [IN]	[OUT] [IN]
Logic	[AND] [OR]			
Sequence	[Single] [Continue]			
ACQ Count	[Infinite]			
Action	<input checked="" type="checkbox"/> Buzzer	<input type="checkbox"/> Save to File	<input type="checkbox"/> Hard Copy	
	<input type="checkbox"/> Image Save	<input type="checkbox"/> Send Mail	Mail Count [100]	

Select whether to perform determination using the corresponding determination parameter (ON/OFF).

Select the determination target waveform from CH1 to CH8 (4), Math1, or Math2.

Select the measurement parameter.

Set the upper and lower limits used to determine the true/false condition of the measure values.

Select which condition when the measured value exits the range defined by the upper and lower limits (OUT) or when the waveform enters the range (IN) is considered true.

Set the determination logic to AND or OR.

Set the determination operation to Single or Continue.

Set the number of waveform acquisitions.

Set the action taken by the DL7400 when the condition is met.

Setting the Determination Range

12. Press the **Time Range1/Time Range2** soft key to set the jog shuttle control to Time Range1, Time Range2, or both Time Range1 and Time Range 2.
 - If you select Time Range1, you can move Time Range1.
 - If you select Time Range2, you can move Time Range2.
 - If you select both Time Range1 and Time Range2, you can move Time Range1 and Time Range2 horizontally without changing the spacing between the two. The value of the digit being specified by Time Range1 changes.

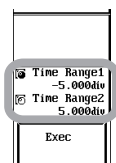

Executing/Aborting Determination

- Press the **Exec** soft key. GO/NO-GO determination is executed. The Exec soft key changes to the Abort soft key. To abort GO/NO-GO determination, press the Abort soft key or press START/STOP. GO/NO-GO determination is aborted, and the word Abort changes to Exec.

Determination display example



Determination count

Exe Count: 60	NG Count: 18
Result: X000	
P-P (C1): 6.083330	Min (C1): -2.916670
Rms (C1): 2.028190	Avg (C1): 106.79800

Number of times the condition is met (NO-GO count)
When all the conditions including the determination logic are met, it is counted as NG (NO-GO).

Determination target waveform, measurement parameter, and measured value of determination parameter Param2

Determination target waveform, measurement parameter, and measured value of determination parameter Param4

Measurement parameter, determination target waveform, and measured value of determination parameter Param1

Measurement parameter, determination target waveform, and measured value of determination parameter Param3

Displays the determination results of each determination parameter in the order Param1 to Param4

(Displays the determination results of determination parameters whose Mode is ON)
 O when the conditions of the determination parameter are not met
 X when the conditions of the determination parameter are met

Explanation

This section explains the setup procedures for performing GO/NO-GO determination based on whether the measured value of the waveform parameter (measurement parameter) exits or enters the range specified by the upper and lower limits.

Determination Target Waveform

The waveform on which GO/NO-GO parameter determination is performed is CH1 to CH8/4*, Math1, or Math2.

* On the DL7440, the waveform is CH1 to CH4, Math1, or Math2. On the DL7480, the waveform is CH1 to CH8, Math1, or Math2.

Determination Parameter

- Up to four determination parameters, Param1 to Param4 can be specified. You can select the determination parameter from the measurement parameters of automated measurement of waveform parameters (including delay between channels).
- You can set the upper and lower limits used to determine the true/false condition of the measured value of the determination parameter in the range of $-9.9999E+30$ to $9.9999E+30$.

Determination Condition and DL7400 Action When the Condition Is Met

For each determination parameter, you can select the following items.

- Determination target waveform (see "Determination Target Waveform" described above).
- Enable or disable determination (ON/OFF).
- Which condition when the measured value exits the range defined by the upper and lower limits of the determination parameter (OUT) or when the measured value enters the range (IN) is considered true.

Determination Logic

You can select the AND logic or OR logic of the determination conditions of the four determination parameters in performing the search.

AND
Condition is considered to be true when all the determination conditions of Param1 to Param4 are met.

OR
Condition is considered to be true when any of the determination conditions of Param1 to Param4 is met.

Determination Operation, Waveform Acquisition Count, DL7400 Action When the Condition Is Met, and Determination Range

They are the same as the GO/NO-GO determination using zones. See section 10.9.

Executing/Aborting GO/NO-GO Determination

- When executed, the determination count, the number of times the condition is met, and the determination result, determination target waveform, measurement parameter, and measured value of each determination parameter are displayed on the screen.
- All keys other than the START/STOP key and the Abort soft key are disabled while determination is in progress.

Note

-
- When GO/NO-GO determination is executed, the trigger mode is automatically set to "Single."
 - Determination is not possible when the acquisition mode is set to Average.
-

10.11 Analyzing and Searching SPI Signals

Procedure

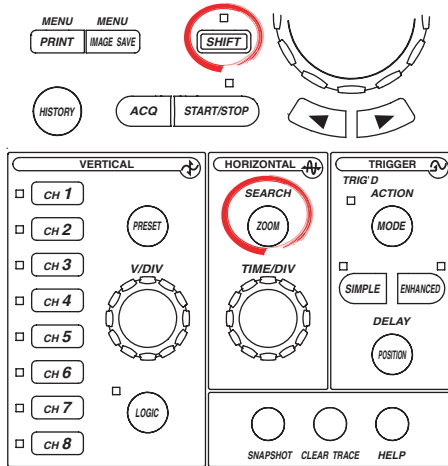

- To exit the menu during operation, press **ESC** located above the soft keys.
- In the procedural explanation below, the term *jog shuttle & SELECT* refers to the operation of selecting/setting items and entering values using the **jog shuttle** and **SELECT** and **RESET** keys. For details on this operation, see sections 4.1 or 4.2.
- For a description of the operation using a USB keyboard or a USB mouse, see section 4.3.

1. Press **SHIFT+ZOOM (SEARCH)**. The SEARCH menu appears.

Selecting the SPI Bus

2. Press the **Type** soft key. The Type menu appears.
3. Press the **To Page 2** soft key.
Depending on the model, the SPI Bus item may appear under the Type menu (Page No. (1/2)) without having to press the To Page 2 soft key.
4. Press the **SPI Bus** soft key.

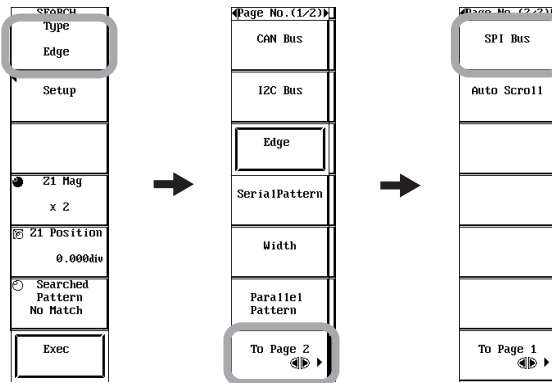

Setting the Analysis Conditions

5. Press the **Analyze Setup** soft key. The Analyze Setup dialog box opens.

Setting the Detection Level, Hysteresis, and Slope of the Synchronization Clock Signal CH1

6. Use **jog shuttle & SELECT** to set the level for detecting the synchronization clock (Level box).
7. Use **jog shuttle & SELECT** to set the hysteresis (width of the level used to detect the synchronization clock, Hysteresis box).

- Use **jog shuttle & SELECT** to select the slope, rising or falling, for detecting the synchronization clock (Polarity box).

Set the level for detecting the synchronization clock.

Set the hysteresis (width of the level used to detect the synchronization clock).

Select which slope edge, rising or falling, of the synchronization clock is to be detected.

Setting the Level for Determining the Status (1 or 0) of the I/O Data

- Use **jog shuttle & SELECT** to select whether Data1 (CH2) is to be analyzed (ON/OFF) (Data1 (CH2) box).
 - Data1 (CH2) will be analyzed when the mark to the left is highlighted.
 - When interleave mode is ON, you cannot set Data1 (CH2).
- Use **jog shuttle & SELECT** to set the level for determining whether the status of Data1 (CH2) is 1 (Thr Upper box).
- Use **jog shuttle & SELECT** to set the level for determining whether the status of Data1 (CH2) is 0 (Thr Lower box).
 - When the data exceeds the specified level (Thr Upper), it is determined to be 1.
 - When the data is below the specified level (Thr Lower), it is determined to be 0.
 - When the data is between the levels specified by Thr Upper and Thr Lower (including the Thr Upper and Thr Lower values), it is determined to be indefinite data.
- Repeat steps 9 to 11 to set the level for determining the status of Data2 (CH3).

Select whether the data is to be analyzed (ON/OFF).

Set the level for determining whether the data status is 1.

Set the level for determining whether the data status is 0.

Setting the Chip Select Signal (CS)

- When Using CH4 to CH8 (CH4) for the CS Signal

- Use **jog shuttle & SELECT** to select the CS signal from CH4 to CH8 (CH4) (CH Level box).

The only channel that can be used on the DL7440 is CH4. You can select from CH4 to CH8 on the DL7480.
- Use **jog shuttle & SELECT** to set the level for determining the status of the CS signal (CH level box on the right).
- On the DL7480, repeat steps 12 and 13 as necessary to set the level for determining the status of CH5 to CH8 as necessary.
- Use **jog shuttle & SELECT** to select whether to make the channel a CS signal (ON/OFF) (each CH box).

The channel is enabled as a CS signal when the mark to the left of the channel is highlighted.

Select a channel from CH4 to CH8 (4).

Select whether the channel is to be a CS signal (ON/OFF).

Set the level for determining the status of the CS signal. (On the DL7480, set the level for determining the status of CH5 to CH8 as necessary.)

10.11 Analyzing and Searching SPI Signals

- **When Using the Logic Input (Optional) Signal for the CS Signal**

17. Use **jog shuttle & SELECT** to select whether to make the logic input a CS signal (ON/OFF) (A0 to A7 box).

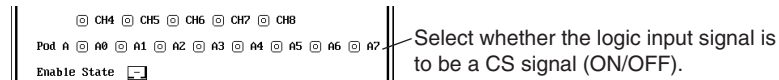

- **Selecting the Enable Status of the CS Signal**

18. Use **jog shuttle & SELECT** to select the enable status of the CS signal from H, L, or X (Enable State box). I/O data is analyzed when the CS signal matches the selected status.

- If multiple CS signals are ON, select the enable status of the CS signal from H and L. You cannot select X.
- The setting in the Enable State box applies to all CS signals.
- If none of the CS signal is ON, the Enable State box displays “-”.

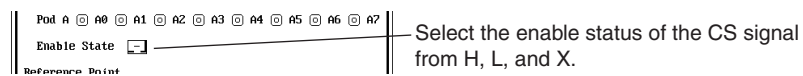

Setting the Reference Point of the Analysis

19. Use **jog shuttle & SELECT** to set the reference point to Trigger Position or Manual (Trigger Position or Manual button).

The reference point is set to the one whose mark to the left is highlighted (Trigger Position or Manual).

20. If the reference point is set to Manual, use **jog shuttle & SELECT** to set the reference point (Manual box on the right).

When setting the reference point using Manual, you can set the reference point while checking the displayed waveform by enabling translucent display. For a description of the translucent display, see section 8.10.

Selecting the Read Direction of the I/O Data Bits

21. Use **jog shuttle & SELECT** to set the read direction of the I/O data bits to MSB First or LSB First (Bit Order box).

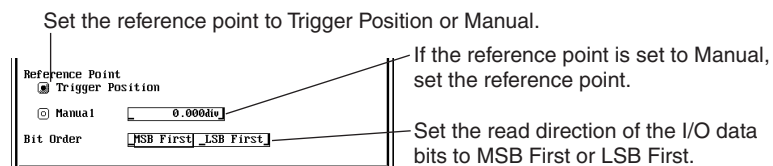

22. Press **ESC**. The Analyze Setup dialog box closes.

Executing/Aborting Analysis

Stop waveform acquisition after displaying the data to be analyzed.

- Press the **Analyze Exec** soft key. The analysis of the I/O data is executed. The words Analyze Exec change to Analyze Abort. To abort the analysis of the I/O data, press the Analyze Abort soft key. The analysis of I/O data is aborted, and the words Analyze Abort change to Analyze Exec.

If indefinite data exists in the analysis data, "*" is attached to the corresponding analysis data.

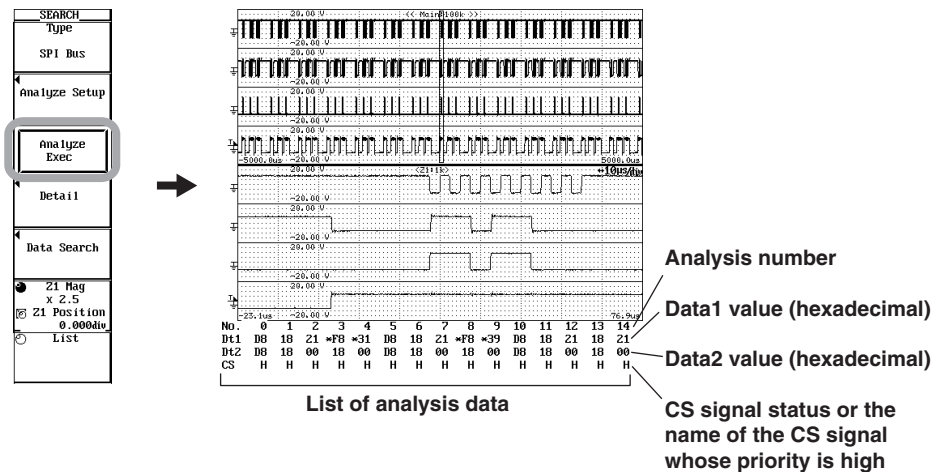

Viewing the Analysis Data

Scrolling the List

- Press the **List** soft key.
- Turn the **jog shuttle** to scroll the list left and right.
Up to 15 analysis data points are displayed at once in the order of occurrence. By scrolling the list left and right using the jog shuttle, analysis data beyond 15 data points can be displayed 5 points at a time.

Setting the Zoom Rate

- Press the **Z1 Mag/Z1 Position** soft key to set the jog shuttle control to Z1 Mag.
- Turn the **jog shuttle** to set the zoom rate.

Setting the Zoom Position

- Press the **Z1 Mag/Z1 Position** soft key to set the jog shuttle control to Z1 Position.
- Turn the **jog shuttle** to set the zoom position. When the center of the zoom box moves to the waveform corresponding to the analysis data on the list, the corresponding analysis data on the list is highlighted.

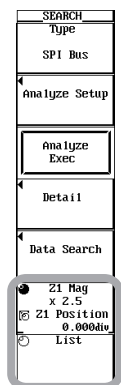

39. Use **jog shuttle & SELECT** to set the determination pattern for each byte in hexadecimal or binary (Data Pattern box). When determination is not to be performed, select X.
40. Press **ESC**. The Detail dialog box closes.

The **Search Setup** dialog box contains the following fields and options:

- Type:** Frame Pattern, Indefinite State
- Pattern Format:** Hex, Bin
- Source:** Data1, Data2
- Data Byte:** 8 byte
- Data Pattern:** A grid of 8 columns (#1-#8) and 2 rows of X's and L's.

Callouts provide the following instructions:

- Set the search type to Frame Pattern or Indefinite State. If Indefinite State is selected, select the search target data in the Source box.
- Set the notation system of the data to be searched to Hex or Bin. The format in the Data Pattern box is set to the format that matches the selected result.
- Set the search target data to Data1 or Data2.
- Select the search unit (data length) in the range of 1 to 8 bytes. The number of bytes displayed in the Data Pattern box is set to the number of bytes that matches the selected result.
- Set the determination pattern per byte using hexadecimal or binary values.

Executing the Search

41. Press the **Next** or **Previous** soft key. The search is executed.
 - When the data matches the determination pattern, the corresponding data (data that was found) is highlighted in the analysis data list at the bottom of the screen. The zoom box moves to the position so that the data that was found is at the center, and the zoomed waveform of the data that was found is displayed in the zoom waveform display area.
 - Pressing the Next soft key searches the data after the highlighted data (to the right) in the analysis data list at the bottom of the screen.
 - Pressing the Previous soft key searches the data before the highlighted data (to the left) in the analysis data list at the bottom of the screen.
 - If you selected Indefinite State (indefinite data) in step 34 and execute the search, indefinite data is highlighted.

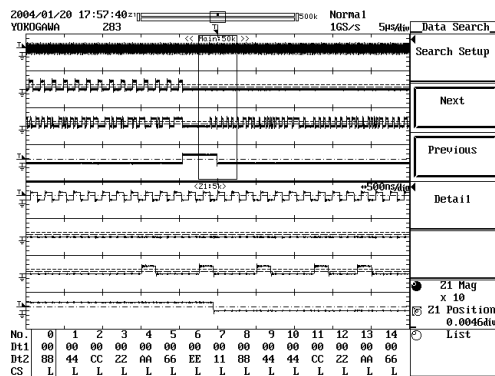

The search is executed to the left.

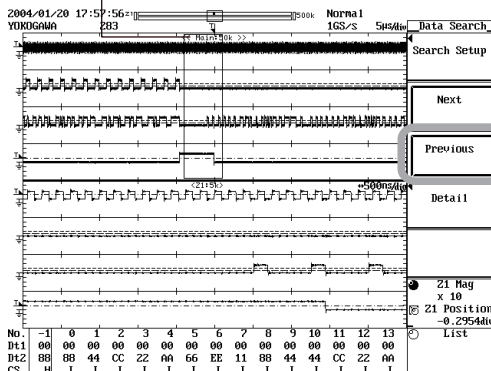

The search is executed to the right.

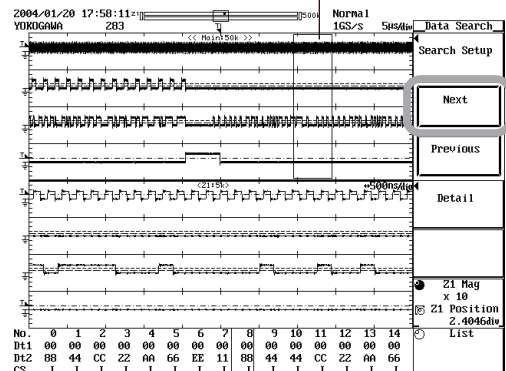

Explanation

This section explains the setup procedure for analyzing or searching the SPI Bus signal while displaying the signal.

SPI Signal Analysis and Search Function

Analysis Function

When waveform acquisition is stopped, the signal data stored to the acquisition memory (including the data stored as history waveforms) can be analyzed. Analysis is performed at the byte level (8 bits) by synchronizing to the clock signal. The analyzed data is listed at the bottom of the screen. The analysis data can be displayed in hexadecimal or binary. The analysis data and signal can be displayed simultaneously.

Search Function

Data that matches a specified determination pattern can be searched from the analysis data (forward search and backward search), and the data that is found can be displayed expanded on the zoom display. You can set the determination pattern in hexadecimal or binary and the data length in the range of 1 to 8 bytes. You can also search indefinite data.

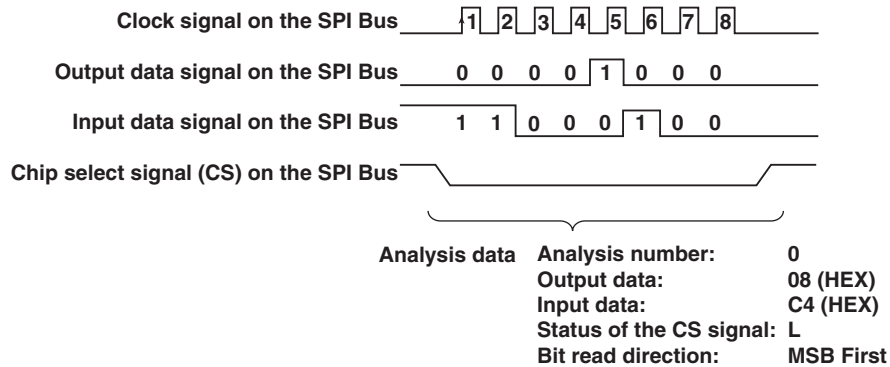

Note

- On the DL7400, the clock signal is applied to CH1, I/O data signal (Data1 and Data2) to CH2 and CH3, and CS signals to CH4 to CH8 or logic input (A0 to A7 of Pod A). CH5 to CH8 can be used on the DL7480. The logic input is optional.
- The SPI Bus analysis function does not have a dedicated trigger.
- A dedicated trigger function is not available on the SPI bus analysis function of the standard model. The function is available on the optional SPI bus analysis function (/F5, /F7, or /F8 option).

Analyzing SPI Signals

By setting analysis conditions, the signal data stored to the acquisition memory can be analyzed.

Analysis Conditions

The following conditions can be specified.

Clock Signal

Apply the clock signal on the SPI Bus to CH1. The status of the I/O data is determined by synchronizing to the clock signal. You can set the detection level, slope, and hysteresis of the clock signal.

• **Level**

You can set the level for detecting the synchronization clock. The selectable range is eight divisions within the screen. The resolution is 0.01 V/div.



- **Hysteresis**

You can set the hysteresis on the level for detecting the synchronization clock. The selectable range is 0.3 divisions to 4.0 divisions. The resolution is 0.1 divisions.

- When the level of the clock signal changes from below the specified lower limit of hysteresis to above and including the upper limit of hysteresis, it is detected as a synchronization clock.
- When the level of the clock signal changes from above the specified upper limit of hysteresis to below and including the lower limit of hysteresis, it is detected as a synchronization clock.
- For all other cases, it is not detected as a synchronization clock.

- **Slope**

You can select which slope edge, rising or falling, of the synchronization clock is to be detected.

	Rising slope
	Falling slope

Data to Be Analyzed

The data that can be analyzed is the I/O data signal on the SPI Bus (Data1 and Data2). The data in the following display range can be analyzed. Apply the Data1 and Data2 signals to CH2 and CH3.

- Waveform data that is displayed when waveform acquisition is stopped.
- History waveform data (waveform selected by Select Record on the History menu).
- Waveform data loaded from a storage medium.

Level for Determining the Status of the Data to Be Analyzed

You can set the level for determining the status of the data to be analyzed. The selectable range is 8 divisions within the screen. The resolution is 0.01 V/div. Thr Upper must be greater than or equal to Thr Lower.

Level for determining 1 (Thr Upper)

You can set the level for determining the status 1. When the data being analyzed exceeds the specified level, it is determined to be 1.

Level for determining 0 (Thr Lower)

You can set the level for determining the status 0. When the data being analyzed is below the specified level, it is determined to be 0.

Between Thr Upper and Thr Lower

The status when the data being analyzed is between the levels specified by Thr Upper and Thr Lower (including the Thr Upper and Thr Lower values) is determined to be indefinite data.

Chip Select Signal (CS)

You can select the signals of CH4 to CH8 or logic input (A0 to A7 of Pod A) for the CS signal on the SPI Bus. CH5 to CH8 can be used on the DL7480. The logic input is optional.

- **Level for Determining the Status of the CS Signal**

When the channel signal is set to be the CS signal, you can set the level for determining the high (H) or low (L) status of the CS signal for each channel. The selectable range is 8 divisions within the screen. The resolution is 0.01 V/div.

- **Use/Not Use as a CS Signal**

You can select whether the channel is to be a CS signal (ON/OFF) for each channel CH4 to CH8 or logic input (A0 to A7 of Pod A).

10.11 Analyzing and Searching SPI Signals

- **Enable Status of the CS Signal**

You can select the enable status of the CS signal. The setting applies to all CS signals.

H	For a channel signal, this is the status when the signal is higher than the level for determining the status of the CS signal. For a logic input signal, this is the status when the signal is 1. The I/O data is analyzed when the CS signal is H.
L	For a channel signal, this is the status when the signal is less than the level for determining the status of the CS signal. For a logic input signal, this is the status when the signal is 0. The I/O data is analyzed when the CS signal is L.
X	Select this status when not determining the status. All the I/O output data are analyzed. The byte boundary of the data being analyzed is the point where the CS signal changes from high to low or low to high. This status cannot be selected when multiple signals are enabled as CS signals.
-	When none of the signals are enabled as a CS signal, this indicator is displayed and cannot be changed. All the I/O output data are analyzed. The data to be analyzed is the I/O data that is divided at the byte level from the analysis reference point (see the next page). Select this status when analyzing the I/O data without using the CS signal.

- **Priority**

Priority exists in the CS signals. When multiple CS signals are enabled, the I/O data corresponding to the CS signal with a high priority is analyzed. The priority in descending order is CH4, CH5, ... , CH8, PodA A0, A1, ..., and A7. When the analysis data is displayed, the name of the CS signal (CH4, CH5, ... , CH8, PodA A0, A1, ..., and A7) that was used when the I/O data was analyzed is displayed in the location where the enable status of the CS signal is displayed.

Reference Point of the Analysis

You can set the reference point where the analysis is to start. The first analysis data as viewed from this reference point is assigned the analysis number 0. For details on the assignment of the analysis number, see "Analysis Numbers" on page 10-85.

Trigger	Sets the reference point to the trigger position.
Manual	You can set the reference point in the range of ± 5 divisions. The resolution is 10 division+display record length.

Read Direction of the I/O Data Bits

You can select the read direction of the bits according to the signal flow. When analysis data is displayed in binary, the data is displayed in the order of the flow regardless of the bit order setting. When analysis data is displayed in hexadecimal, the data is displayed according to the setting, separated every four bits in the order of the flow.

MSB First	Select this when the I/O data signal is flowing MSB first.
LSB First	Select this when the I/O data signal is flowing LSB first.

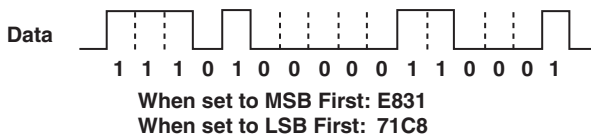

Range That Can Be Analyzed

Up to 80000 bytes of analysis data can be displayed. The displayed result varies depending on the number of bytes analyzed as follows:

- When the total analysis data is less than or equal to 80000 bytes
All points are displayed regardless of the position of the reference point.

- When the total analysis data is greater than 80000 bytes
The displayed result varies depending on the number of analysis data in the Pre and Post sections as follows:

When the Pre section contains 44000 points and the Post section contains 44000 points, 40000 data points in the Pre section and 40000 data points in the Post section are displayed.

When the Pre section contains 8000 points and the Post section contains 80000 points, 8000 data points in the Pre section and 72000 data points in the Post section are displayed.

When the Pre section contains 80000 points and the Post section contains 8000 points, 72000 data points in the Pre section and 8000 data points in the Post section are displayed.

* Pre: Before (left) of the reference point. Post: After (right) of the reference point

Analysis Data List

The following four items are displayed.

- Analysis number
- Data1 value (hexadecimal)
- Data2 value (hexadecimal)
- CS signal status or the name of the CS signal whose priority is high

Analysis Numbers

Up to 80000 bytes can be displayed. Depending on whether the CS signal is ON, the data of analysis number 0 (byte level) is defined as follows. The data points that are newer than the data point of analysis number 0 (to the right on the screen) are assigned numbers 1, 2, 3, and so on as the data points get newer. The data points that are older than the data point of analysis number 0 (to the left on the screen) are assigned numbers -1, -2, -3, and so on as the data points get older.

- When None of the CS Signals Is ON**

The first detected data after the reference point becomes analysis number 0.

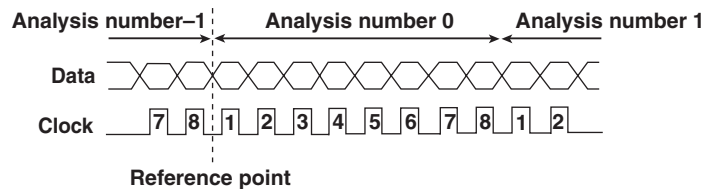

- When the CS Signal Is ON**

The data containing the reference point becomes analysis number 0. However, if the reference point is between two data points, the first detected data after the reference point becomes analysis number 0.

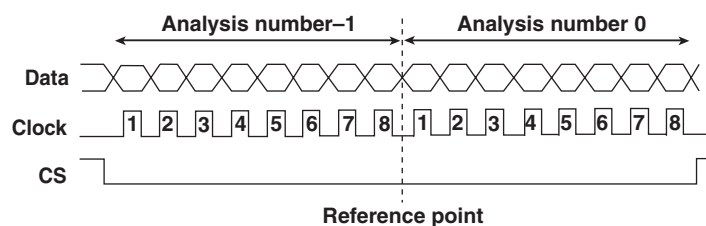
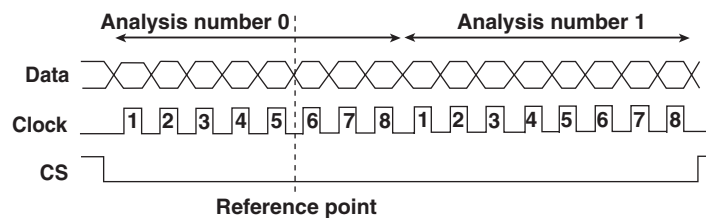

Data1 and Data2 Values

The Data1 and Data2 values are displayed in hexadecimal. Below are some exceptions.

- When the data is less than 8 bits, “-” is displayed.
- When indefinite data (bit whose status is neither 1 or 0) exists, “*” is displayed. Indefinite data is considered the same status as the previous bit for the analysis. If the first bit (left most bit in the display range) is indefinite data, it is analyzed as 0.

CS

Displays the CS signal enable status. Note the following:

- When none of the CS signal is ON, blank is displayed.
- When only one CS signal is ON, the status H or L of the CS signal is displayed.
- When multiple CS signals are ON, the name of the CS signal with high priority is displayed. For a description of the priority, see page “Priority” on page 10-84.

Display Example of Analysis Data

Below is an example of the analysis data when analysis is performed by changing the analysis condition of one set of I/O data.

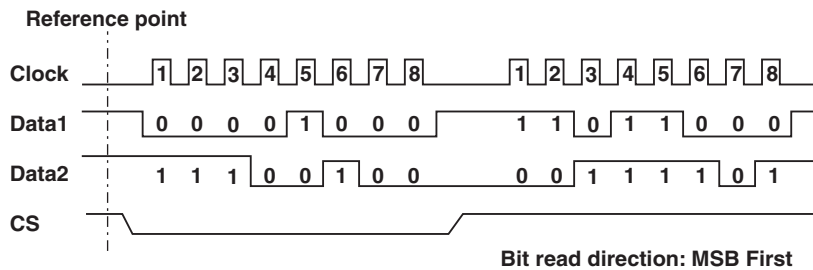

• **Analysis Condition Clock (CH1) = f and CS (CH4) = L**

Display Item	Analysis Data Display
Analysis number (No.)	0
Hexadecimal display of Data1 (Dt1)	08
Hexadecimal display of Data2 (Dt2)	E4
Status of the CS signal (CS)	L

• **Analysis Condition Clock (CH1) = f and CS (CH4) = H**

Display Item	Analysis Data Display
Analysis number (No.)	0
Hexadecimal display of Data1 (Dt1)	D8
Hexadecimal display of Data2 (Dt2)	3D
Status of the CS signal (CS)	H

• **Analysis Condition Clock (CH1) = f and CS (CH4) = X**

Display Item	Analysis Data Display
Analysis number (No.)	0 1
Hexadecimal display of Data1 (Dt1)	08 D8
Hexadecimal display of Data2 (Dt2)	E4 3D
Status of the CS signal (CS)	L H

Note

- If an arbitrary data is selected (highlighted) in the analysis data slit, the zoom position moves to the beginning of the data. Conversely, if you move the zoom position, the data corresponding to the zoom position is highlighted.
- If the CS signal is ON and the CS signal on the main waveform display screen does not contain a transition point from H to L or L to H, the I/O data is not analyzed.
- Analysis and search is not possible while waveform acquisition is in progress.
- Analysis and search cannot be performed on accumulated waveforms. However, analysis and search are possible on the accumulated waveform remaining as a history waveform.

Detailed List of Analysis Data

More detailed information of the analysis data can be listed. The following information can be displayed.

- Analysis number
- Time from the reference point
Displays the time from the reference point to the first bit of each data point.
- Data1 and Data2 values
You can display the values by selecting hexadecimal or binary for the notation system. However, if the data does not consist of 8 bits or if indefinite data exists, the display is the same as “Data1 and Data2 Values” on page 10-85.
- Status of the CS signal

Searching SPI Signals

You can search analysis data that matches a data pattern or an indefinite data condition. If analysis data that matches the specified condition is found, the zoom position moves to the corresponding section, and the waveform of the data that is found is displayed in the zoom waveform display frame.

Search Type

You can select the search type.

Frame Pattern

Searches the analysis data of Data1 or Data2 that matches the determination pattern specified at the byte level.

Indefinite State

Searches indefinite data from the analysis data of Data1 or Data2.

Search Condition

When the Search Type Is Frame Pattern

You can search the analysis data of Data1 or Data2 that matches the determination pattern specified at the byte level. Specify the following items.

- **Notation System of the Determination Pattern**
Set the notation system of the specified determination pattern to hexadecimal or binary. The notation of the determination pattern described later changes accordingly.
- **Search Target Data**
Set the search target data to Data1 or Data2.
- **Data Length of the Determination Pattern**
Select the data length of the determination pattern in the range of 1 to 8 bytes. The number of specified bytes of the determination pattern described later changes accordingly.
- **Determination Pattern**
Set the determination pattern according to the notation system setting (hexadecimal or binary).
 - Bits that are set to “X” are not determined. Such bits are always handled as though the data matches the determination pattern regardless of the status.
 - If there are bits set to X in binary, \$ is displayed when the notation system is changed to hexadecimal.
 - The read direction of the bits is the same as the setting for the analysis (see section 10-84).

When the Search Type Is Indefinite State

You can search indefinite data from the analysis data of Data1 or Data2 at the bit level. Set the search target data to Data1 or Data2.

10.11 Analyzing and Searching SPI Signals

Note

- Indefinite data is always considered matched to the specified status.
- If analysis is performed with CS signal set to ON, the data being analyzed is considered to be delimited at the point where the status of the CS signal changes. In this case, search is also performed by considering the data to be delimited at that point. For example, if a total of 5 bytes consisting of the data to be analyzed and CS signal as shown in the following figure is analyzed by changing the CS signal setting, search cannot be performed using the same conditions.
- Analyzing with the CS signal set to ON (enable status of the CS signal is set to L)
Because data cannot be searched over two CS intervals, search cannot be performed with the data length of the determination pattern to 4 or 5 bytes.
- Analyzing with None of the CS signals set to ON
The data length of the search target data and the CS interval are independent. Searching is possible with the data length of the determination pattern set to 4 or 5 bytes.

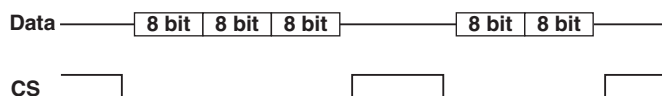

11.1 Installing the Roll Paper into the Built-in Printer (Optional)

Printer Roll Paper

The DL7400 uses a dedicated roll paper provided by YOKOGAWA. Do not use other types of roll paper. When you are using the printer for the first time, use the roll paper that came with the package. Order extra rolls from your nearest YOKOGAWA dealer.

Part No.	B9850NX
Specifications	Thermalsensible paper, 30 m
Minimum Quantity	5 rolls

Handling the Roll Paper

The paper is a thermalsensible paper that changes color with the application of heat. Take note of the following points.

Storage Precautions

The paper starts changing color at around 70°C. It is affected by heat, humidity, light, and chemicals regardless of whether the paper has been used.

- Store the paper rolls in a cool, dry, and dark place.
- After opening the package, use it quickly.
- If the paper is left in contact with plastic film (such as a vinyl chloride film or Scotch tape) containing plasticizers for an extended time, the paper will lose some of its ability to reproduce color. If you are going to store the paper in a folder, for example, use a folder made of polypropylene or wood fiber.
- When using glue on the paper, do not use glue containing organic solvents such as alcohol or ether, as they will change the color of the paper.
- For prolonged storage, we suggest you make copies of the results printed on the roll paper. Due to the characteristics of the thermalsensible paper, it may lose color over time.

Handling Precautions

- Be sure to use only genuine paper rolls provided by YOKOGAWA.
- Touching the paper with sweaty hands can leave finger print marks or blur the printing.
- Rubbing the surface with a hard object can cause the paper to change color due to the heat caused by friction.
- If chemicals, oil, or other liquids come in contact with the paper, the paper may change color or the printing may fade.

11.1 Installing the Roll Paper into the Built-in Printer (Optional)

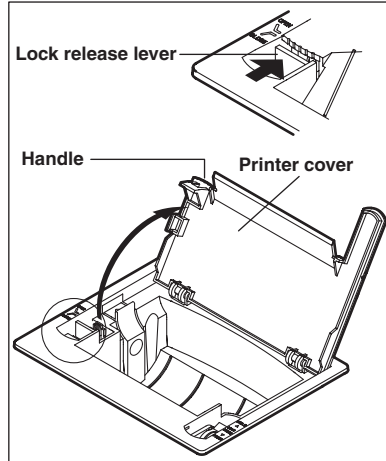

To open the printer cover, lift the handle on the left side of the printer cover while pressing the lock release lever to the OPEN direction.

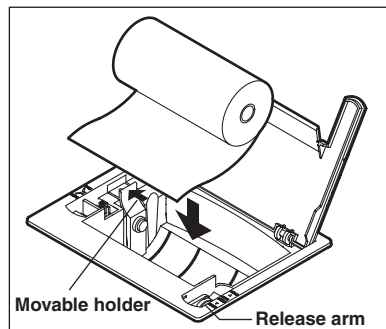

Move the release arm located on the right near the front to the MAN FEED position. Hold the roll paper so that the inner side of the roll paper (the side that is not glossy) is facing up. Pull the movable holder to the left, then insert the roll paper side-side first into the tray. Release the movable holder to secure.

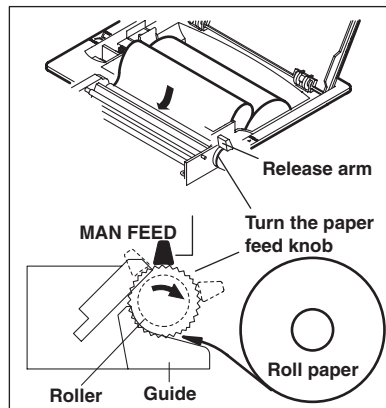

Insert the edge of the roll paper evenly in the space between the roller and the black guide, then rotate the paper feed knob towards you until about 10 cm of the paper extends beyond the top of the roller.

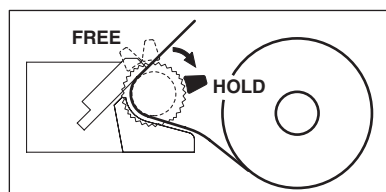

Move the release arm to the FREE position and straighten out the paper. Then, move the release arm to the HOLD position. The printing will fail with an error message if the release arm is in the FREE or MAN FEED position during operation.

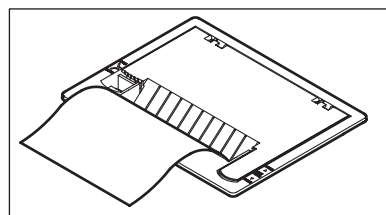

Pull the printer cover back to its original position and close the cover. Make sure that the edge of the roll paper feeds through the opening of the printer cover. Push the printer cover down firmly until it clicks into place.

Note

The paper feeding may not be stable immediately after the roll paper is installed. Print 2 or 3 pages of test images in advance.

11.2 Printing Using the Built-in Printer (Optional)

Procedure

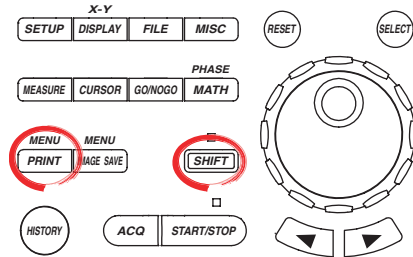

- To exit the menu during operation, press **ESC** located above the soft keys.
- In the procedural explanation below, the term *jog shuttle & SELECT* refers to the operation of selecting/setting items and entering values using the **jog shuttle** and **SELECT** and **RESET** keys. For details on this operation, see sections 4.1 or 4.2.
- For a description of the operation using a USB keyboard or a USB mouse, see section 4.3.

1. Press **SHIFT+PRINT (MENU)**. The PRINT menu appears.

Selecting the Built-in Printer

2. Press the **Print to** soft key. The Print to menu appears.
Net Print appears only if the Ethernet interface option is installed.
3. Press the **Built-in** soft key.

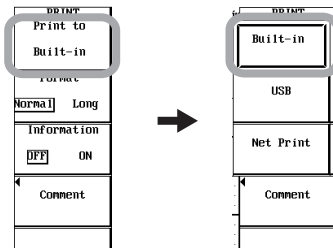

Selecting the Print Format

4. Press the **Format** soft key to select Normal or Long.
 - If you select Normal, proceed to step 9.
 - If you select Long, proceed to step 5.

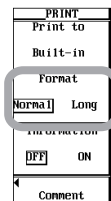

Setting the Magnification

5. Press the **Mag** soft key. The number of pages that will be printed at the specified Mag value (magnification) is displayed.
6. Turn the **jog shuttle** to set the magnification.

Setting the Print Range

7. Press the **Time Range1/Time Range2** soft key to set the jog shuttle control to Time Range1, Time Range2, or both Time Range1 and Time Range 2.
 - If you select Time Range1, you can move Time Range1.
 - If you select Time Range2, you can move Time Range2.
 - If you select both Time Range1 and Time Range2, you can move Time Range1 and Time Range2 horizontally without changing the spacing between the two. The value of the digit being specified by Time Range1 changes.
8. Turn the **jog shuttle** to set the print range.

11.2 Printing Using the Built-in Printer (Optional)

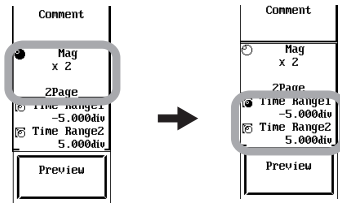

Turning ON/OFF the Additional Information and Comments

9. Press the **Information** soft key to select ON or OFF.
10. Press the **Comment** soft key. A keyboard used to enter values and strings appears.
11. Use **jog shuttle & SELECT** to set the comment.

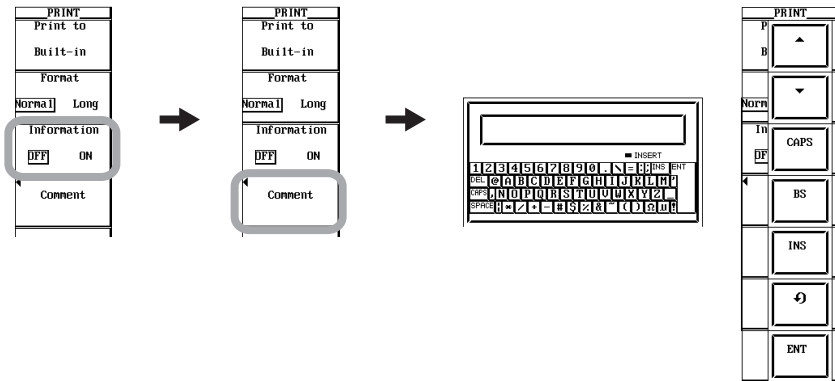

Previewing the Print Image

12. Press the **Preview** soft key. The Preview menu and the print image per page are displayed. The word Preview changes to Quit.
13. Turn the **jog shuttle** to select the page within the range of the total number of pages that vary depending on the magnification specified in step 5. The print image of the selected page is displayed.
14. To exit from the print image preview, press the **Quit** soft key.
You can also exit from the print image preview by pressing other soft keys and panel keys excluding a portion of the keys.

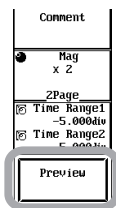

Executing the Print Operation

15. Press **PRINT**. The screen image is printed on the built-in printer. To abort printing, press PRINT while printing is in progress. While printing is in progress,  is indicated at the upper left corner of the screen.

11.3 Printing Using a USB Printer

Procedure

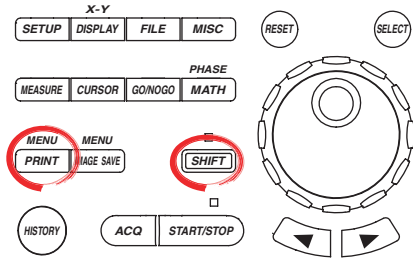

- To exit the menu during operation, press **ESC** located above the soft keys.
- In the procedural explanation below, the term *jog shuttle & SELECT* refers to the operation of selecting/setting items and entering values using the **jog shuttle** and **SELECT** and **RESET** keys. For details on this operation, see sections 4.1 or 4.2.
- For a description of the operation using a USB keyboard or a USB mouse, see section 4.3.

1. Connect the DL7400 and a USB printer using a USB cable. For details, see the explanation in this section (page 11-9).

Selecting the USB Printer

2. Press **SHIFT+PRINT (MENU)**. The PRINT menu appears.
3. Press the **Print to** soft key. The Print to menu appears.
Built-in and Net Print appear if the built-in printer option and the Ethernet interface option are installed, respectively.
4. Press the **USB** soft key.

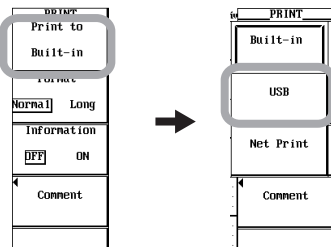

Checking the Connected Printer

5. Press the **Select** soft key. The USB Device List window appears. Check the printer that is connected.

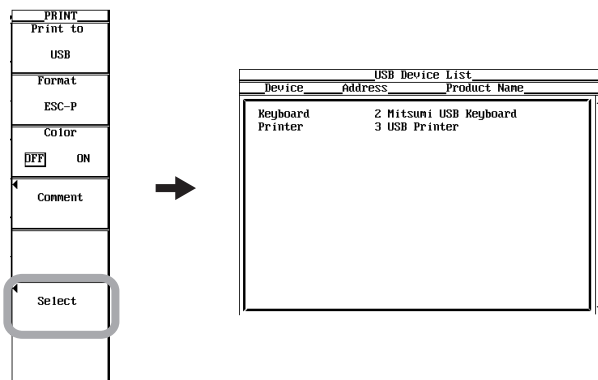

Note

You can also check the printer that is connected from the MISC > USB > Device List menu.

Selecting the Page Description Language or Printer Type

6. Press the **Format** soft key. The Format menu appears.
7. Press **ESC-P**, **ESC-P2**, **LIPS3**, **PCL5**, or **BJ** to select the page description language or printer type.

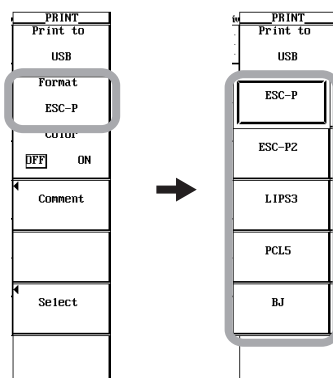

Turning ON/OFF Color Printing

(Selectable if the page description language or printer type is set to ESC-P, ESC-P2, PCL5, or BJ in step 7)

8. Press the **Color** soft key to select ON or OFF.

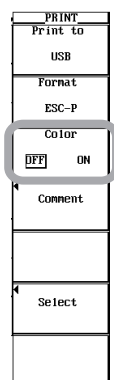

Setting Comments

9. Press the **Comment** soft key. A keyboard used to enter values and strings appears.
10. Use **jog shuttle & SELECT** to set the comment.

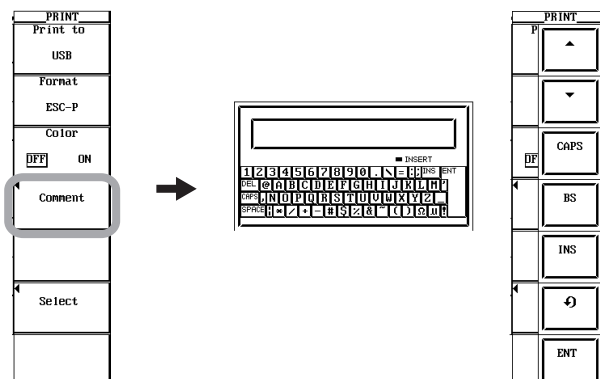

Selecting the Print Resolution

(Selectable only if the page description language or printer type is set to BJ in step 7)

11. Press the **Resolution** soft key. The Resolution menu appears.
12. Press the **180dpi**, **300dpi**, **360dpi**, or **600dpi** soft key to set the output resolution.

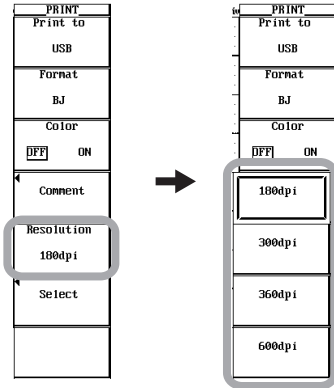

Executing the Print Operation

13. Press **PRINT**. The screen image is printed on the USB printer. To abort printing, press PRINT while printing is in progress. While printing is in progress,  is indicated at the upper left corner of the screen.

Explanation

You can print the screen image to a USB printer via the USB PERIPHERAL interface.

Connecting the DL7400 and the USB Printer

USB PERIPHERAL connector

To connect a USB printer to the DL7400, connect a USB cable to the USB PERIPHERAL connector. There are two USB PERIPHERAL connectors (ports).

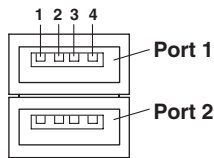

USB PERIPHERAL

Pin No.	Signal Name
1	VBUS: +5 V
2	D-: -Data
3	D+: +Data
4	GND: Ground

Printers That Can Be Used

USB printers conforming to USB Printer Class Version 1.1 that support the following print formats can be used.

Note

- Connect only the printers that are allowed.
- For details on USB printers that have been tested for compatibility, contact your nearest YOKOGAWA dealer.

Connection Procedure

When connecting a USB printer, directly connect the printer to the DL7400 using a USB cable as shown below. You can connect the USB cable regardless of the power ON/OFF state of the DL7400 (supports hot-plugging). Connect the type A connector of the USB cable to the DL7400; connect the type B connector to the printer. When the power switch is ON, the printer is detected and enabled approximately six seconds after it is connected.

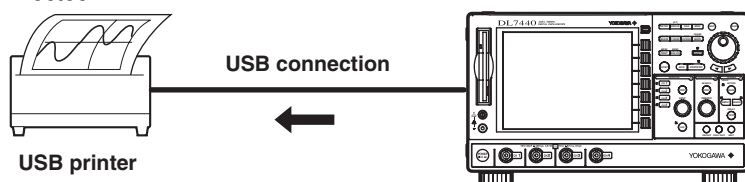

Note

- Connect the printer directly without going through a hub.
- Do not connect USB devices other than USB keyboard, USB mouse, and USB printer, and USB storage that can be used to the USB PERIPHERAL connector.
- Do not connect multiple printers to the USB PERIPHERAL connector.
- Do not turn OFF the printer or remove the USB cable while the printer is printing.
- Do not connect or disconnect the USB cable after the power is turned ON until key operation is ready (approximately 20 to 30 s).

Page Description Language or Printer Type

You can select the page description language and printer type.

ESC-P, ESC-P2, LIPS3, PCL5, or BJ (can be used on models that support the BJC-35V native commands)

Print Resolution

(Only when the page description language or printer type is set to BJ)

You can select the print resolution of screen images to match the resolution of the USB-compatible BJ printer.

180 dpi, 300 dpi, 360 dpi, and 600 dpi

Comment

A comment text of up to 20 characters can be printed at the bottom of the print page. The entered comment is displayed at the lower right section of the screen.

Turning ON/OFF Color Printing

You can select whether to print in color if the page description language or printer type is set to ESC-P, ESC-P2, PCL5, or BJ.

ON

Prints the image using the same colors as the screen (no background color and grid printed in black).

OFF

Prints the image using the same colors as the image printed using the built-in printer.

Note

- The DL7400 does not detect “out of paper” and printer errors on the USB printer. If an error occurs, press PRINT again to stop the printing.
 - Images may not print properly on some printers. Use USB printers that have been tested for compatibility.
 - You can also print to a USB printer that is connected to your PC. In this case, save the screen image data to a floppy disk, Zip disk, PC card, or other storage medium (see section 12.12), load the data into your PC, and print the data.
-

11.4 Printing Using a Network Printer (Optional)

Procedure

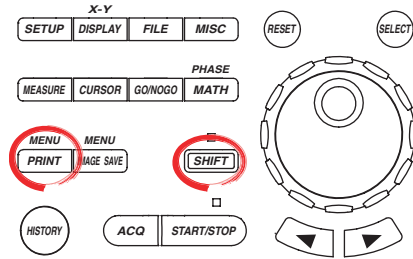

- To exit the menu during operation, press **ESC** located above the soft keys.
- In the procedural explanation below, the term *jog shuttle & SELECT* refers to the operation of selecting/setting items and entering values using the **jog shuttle** and **SELECT** and **RESET** keys. For details on this operation, see sections 4.1 or 4.2.
- For a description of the operation using a USB keyboard or a USB mouse, see section 4.3.

Configuring the Network

1. After making a network connection (see section 13.1), enter TCP/IP settings (see section 13.2) and settings for printing screen images to a network printer (see section 13.4.).

Selecting a Network Printer

2. Press **SHIFT+PRINT (MENU)**. The PRINT menu appears.
3. Press the **Print to** soft key. The Print to menu appears.
Built-in and Net Print appear if the built-in printer option and the Ethernet interface option are installed, respectively.
4. Press the **Net Print** soft key.

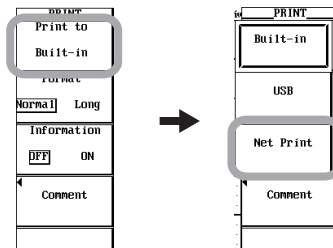

Selecting the Page Description Language or the Printer Type

5. Press the **Format** soft key. The Format menu appears.
6. Press **Post Script, LIPS3, PCL5, ESC-P, ESC-P2, or BJ** to select the page description language or the printer type.

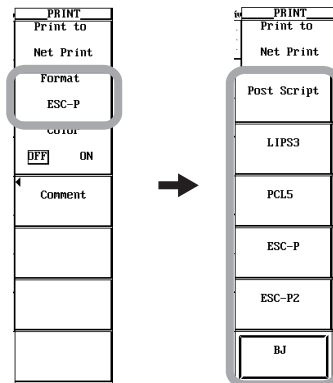

11.4 Printing Using a Network Printer (Optional)

Turning ON/OFF Color Printing

(Selectable only if the page description language or printer type is set to PCL5, ESC-P, ESC-P2, or BJ in step 6)

7. Press the **Color** soft key to select ON or OFF.

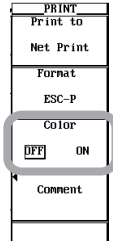

Setting Comments

8. Press the **Comment** soft key. A keyboard used to enter values and strings appears.
9. Use **jog shuttle & SELECT** to set the comment.

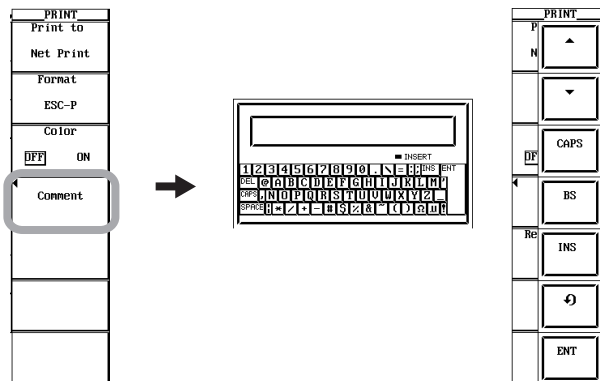

Selecting the Print Resolution

(Selectable only if the page description language or printer type is set to BJ in step 6)

10. Press the **Resolution** soft key. The Resolution menu appears.
11. Press the **180dpi**, **300dpi**, **360dpi**, or **600dpi** soft key to set the output resolution.

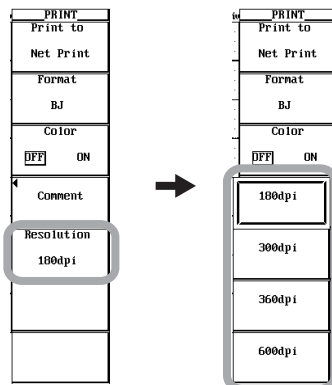

Executing the Print Operation

12. Press **PRINT**. The screen image is printed on the network printer. To abort printing, press PRINT while printing is in progress. While printing is in progress,  is indicated at the upper left corner of the screen.

Explanation

Like the built-in printer, you can print the screen image on a network printer* via the Ethernet network.

* Printing is possible on a printer or via a printer server supporting the TCP/IP protocol.

Page Description Language or Printer Type

You can select the page description language and printer type.

Post Script, LIPS3, PCL5, ESC-P, ESC-P2, or BJ (can be used on models that support the BJC-35V native commands)

Print Resolution

(Only when the page description language or printer type is set to BJ)

You can select the print resolution of screen images to match the resolution of the BJ printer on the network.

180 dpi, 300 dpi, 360 dpi, and 600 dpi

Comment

A comment text of up to 20 characters can be printed at the bottom of the print page. The entered comment is displayed at the lower right section of the screen.

Turning ON/OFF the Color Printing

You can select whether to print in color only if the page description language or printer type is set to PCL5, ESC-P, ESC-P2, or BJ.

ON

Prints the image using same colors as the screen (no background color and grid printed in black).

OFF

Prints the image using the same colors as the image printed using the built-in printer.

12.1 Storing and Recalling Setup Data

Procedure

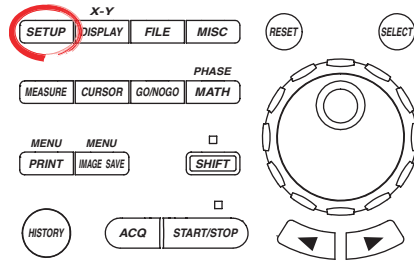

- To exit the menu during operation, press **ESC** located above the soft keys.
- For a description of the operation using a USB keyboard or a USB mouse, see section 4.3.

1. Press **SETUP**. The SETUP menu appears.
2. Press the **Store/Recall** soft key. The Store/Recall menu appears.

Storing Setup Data

3. Press any soft key from **Store #1 to Store #3** to store the setup data. When the setup data is stored, the date of storage is displayed in the soft key menu.

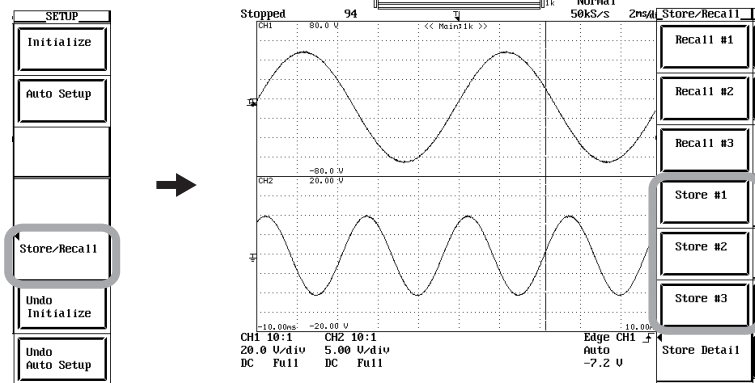

4. Press the **Store Detail** soft key to display the details of the store operation. To enter a comment, follow the procedure described in section 4.2. There is a lock switch that you can use to protect (lock) overwriting the stored data. Turn the **jog shuttle** to move the cursor to the lock button corresponding to the store number that you wish to lock. Press **SELECT** to lock the data. Press **SELECT** again to release the lock.

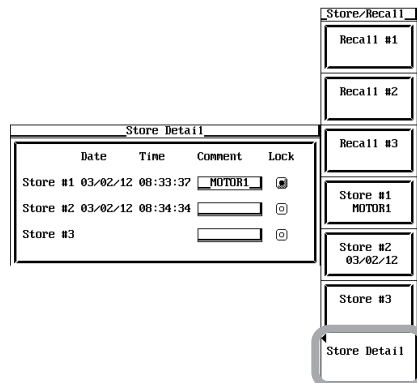

12.1 Storing and Recalling Setup Data

Recalling Setup Data

3. Press one of the soft keys **Recall #1** to **Recall #3** to recall the setup data.

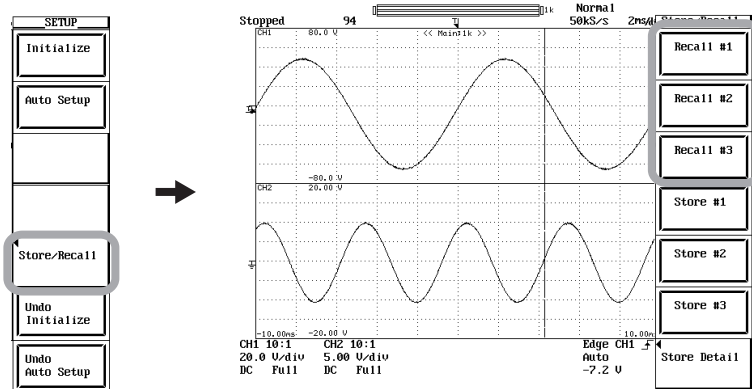

Explanation

Stored Items

All of the information that you entered using the soft key menu or jog shuttle menu, START/STOP, and the ON/OFF conditions of channels are stored.

Storage Destination of the Setup Data

You can store the setup data to three memory locations, Store #1 through Store #3. If the setup data is already stored at the selected number, the previous data is overwritten. However, an error message is displayed if the data is locked.

Recalled Setup Data

Select the setup data that is stored in the three memory locations, Recall #1 through Recall #3. You can only select memory locations that have setup data stored.

Note

The stored setup data is not cleared even if you initialize the settings on the DL7400.

12.2 Floppy Disk, Zip Disk, and PC Cards

Three types of built-in storage are available: a floppy disk drive or a Zip disk drive (either type is selected at the time of purchase) or a PC card drive. For a description of the Zip disk drive, see page 12-4. For a description of the PC card drive, see page 12-5.

Floppy Disks

Floppy Disks That Can Be Used

The following type of 3.5" floppy disk can be used. Formatting is also possible on the DL7400.

2HD

Formatted to 1.44 MB using MS-DOS.

Inserting a Floppy Disk into the Floppy Disk Drive

With the label facing toward the right, insert the disk. Insert the disk until the eject button pops out.

Removing the Disk from the Floppy Disk Drive

Check that the access indicator is turned OFF and press the eject button.

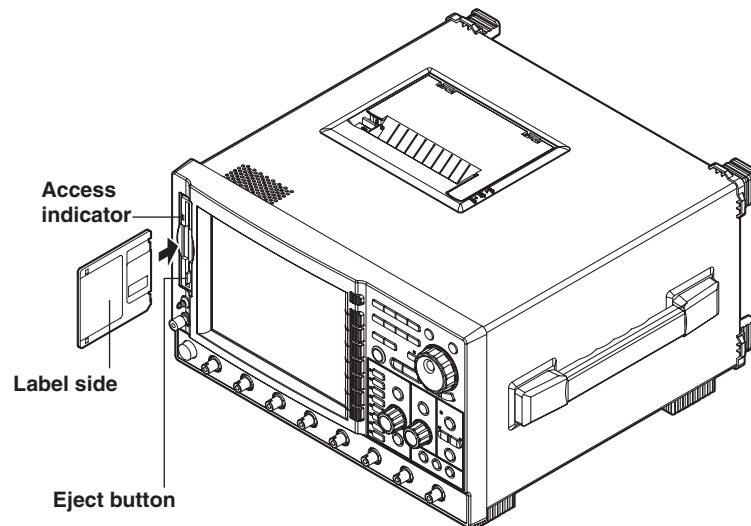

CAUTION

Removing the floppy disk while the access indicator is blinking can damage the magnetic head of the floppy disk drive or destroy the data on the floppy disk.

General Handling Precautions of Floppy Disks

Floppy disks with bad sectors cannot be used on the DL7400. Format the floppy disk using your PC or other device before use. For the general handling precautions of the floppy disk, read the instruction manual that came with the floppy disk.

Zip Disks

Zip Disks That Can Be Used

The following types can be used. Formatting is also possible on the DL7400.

Capacity	100 MB and 250 MB
Disk Format	FDISK 1 partition (hard disk format)

Inserting the Zip Disk into the Zip Drive

With the label facing toward the right, insert the disk.

Removing the Zip Disk from the Zip Drive

With the DL7400 turned ON, check that the access indicator is OFF and press the eject button. If you need to use the Zip disk again, wait at least three seconds after removing it before reinserting it into the drive.

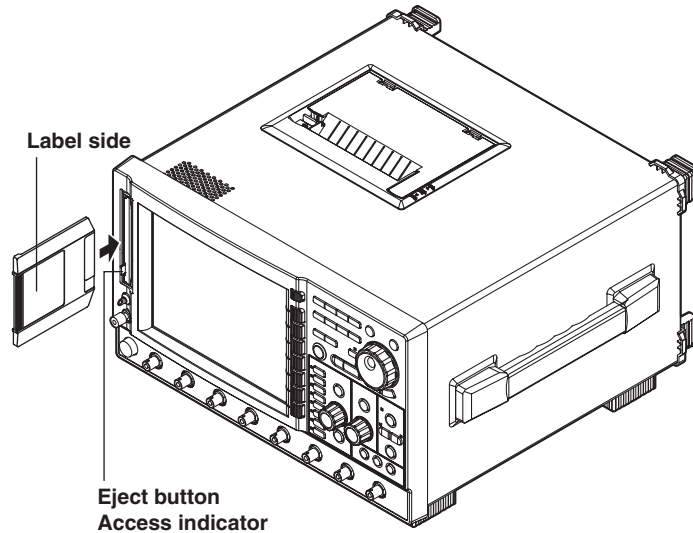

Procedure When the Zip Disk Cannot Be Ejected

If the Zip disk cannot be removed by performing the steps above, carry out the following steps to remove it.

Insert a pin of approximately 1 mm in diameter into the eject button hole and press slowly. This will cause the Zip disk to be ejected.

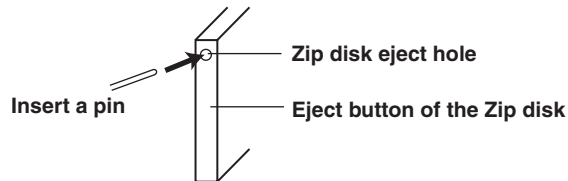
**CAUTION**

- Removing the Zip disk while the access indicator is ON may destroy the data on the Zip disk.
- Do not use the Zip drive if the DL7400 is installed in a tilted position using the stand. (For the installation position, see section 3.2.)
- When turning ON/OFF the DL7400, have the Zip disk removed from the drive.
- Do not insert the Zip disk into the drive, or remove the Zip disk from the drive while the DL7400 is starting up after turning ON the power (see section 3.3, "Power Up Operation"). Doing so can damage the disk.
- The access indicator illuminates immediately after the Zip disk is inserted. Do not operate the DL7400 while the access indicator is illuminated. Doing so can lead malfunction.

General Handling Precautions of Zip Disks

For the general handling precautions of the Zip disk, read the instruction manual that came with the Zip disk.

PC Cards**PC Cards That Can Be Used**

The DL7400 supports flash ATA cards (PC card TYPE II) and compact flash (using the PC card TYPE II adapter). In addition, some of the Flash ATA HDD cards can be used. For details, contact your nearest YOKOGAWA dealer.

Note

To use the PC card on the PC, use a PC that supports the PC card. Depending on the PC that you are using, the PC cards indicated above may not operate properly. Check it beforehand.

Inserting the PC Card

With the front side of the PC card facing toward you, insert the PC card into the drive. The PC card drive is located on the rear panel of the DL7400.

Note

Insert the PC card all the way in. If not inserted firmly, the DL7400 may not be able to detect it correctly.

Ejecting the PC Card

Check that the PC card is not being accessed, and press the PC card eject button to the right of the drive.

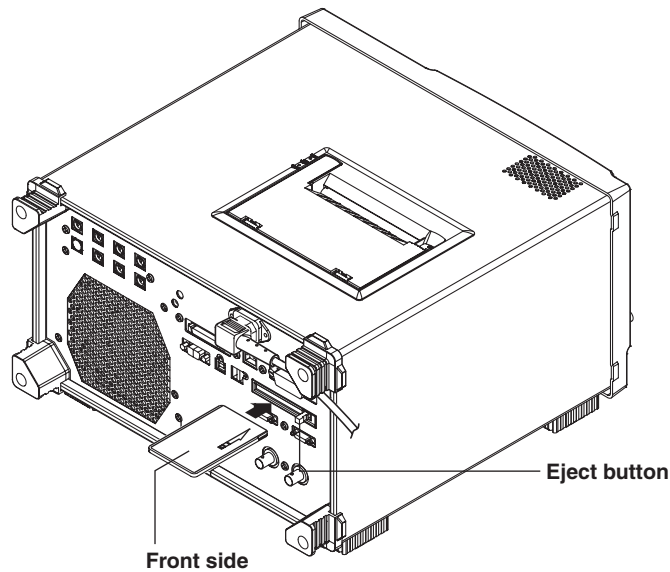

CAUTION

- The DL7400 may malfunction if the PC card is inserted and ejected within a 1-second time period.
 - Removing the PC card while it is being accessed may destroy the data on the PC card.
-

General Handling Precautions of PC Cards

For the general handling precautions of the PC card, read the instruction manual that came with the PC card.

12.3 Connecting MO Disk Drives or Hard Disks to the SCSI

SCSI Specifications

Item	Specifications
Interface standard	SCSI (Small Computer System Interface), ANSI X3.131-1986
Connector type	Half pitch 50 pins (pin type)
Connector pin assignment	Unbalanced (single-ended), see table below.

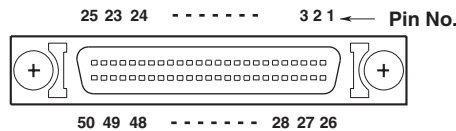

Pin No.	Signal Name	Pin No.	Signal Name
1 to 12	GND	38	TERMPWR
13	NC	39, 40	GND
14 to 25	GND	41	-ATN
26	-DB0	42	GND
27	-DB1	43	-BSY
28	-DB2	44	-ACK
29	-DB3	45	-RST
30	-DB4	46	-MSG
31	-DB5	47	-SEL
32	-DB6	48	-C/D
33	-DB7	49	-REQ
34	-DBP	50	-I/O
35 to 37	GND		

Items Necessary for Connection

Cable

Use a commercially sold cable that is three meters or less in length, has a ferrite core on each end of the cable, and has a characteristic impedance between 90 and 132 Ω .

Connection Procedure

1. Connect the SCSI cable to the SCSI connector on the rear panel of the DL7400.
2. Turn ON the SCSI device and the DL7400 (in that order). To format a disk, follow the procedures given in section 12.6.

SCSI Devices That Can Be Connected

Most SCSI devices (MO disk drive or hard disk) can be connected to the instrument, but there are some exceptions. For details on which devices can be connected, contact your nearest YOKOGAWA dealer as listed on the back cover of this manual. For general handling precautions for the connected SCSI device, see the instruction manual that is provided with the device.

Note

- When connecting multiple SCSI devices in a chain, attach a SCSI terminator to the device at the other end of the chain.
- Hard disks that are formatted with the DL7400 cannot be read using the NEC PC-9800 Series computers.

12.4 Changing the SCSI ID Number

Procedure

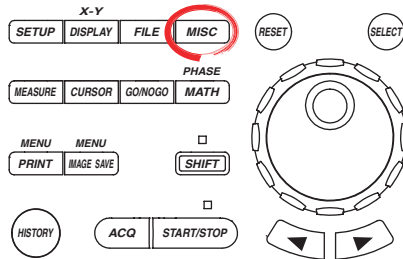

- To exit the menu during operation, press **ESC** located above the soft keys.
- For a description of the operation using a USB keyboard or a USB mouse, see section 4.3.

1. Press **MISC**. The MISC menu appears.
2. Press the **SCSI ID** soft key. The SCSI ID menu appears.
3. Turn **jog shuttle** to select 0 to 7.
4. Press the **Initialize SCSI** soft key. The SCSI ID is changed to the selected ID number. The SCSI icon at the upper right corner of the screen blinks while the change is in progress. When the change is complete, the icon disappears.

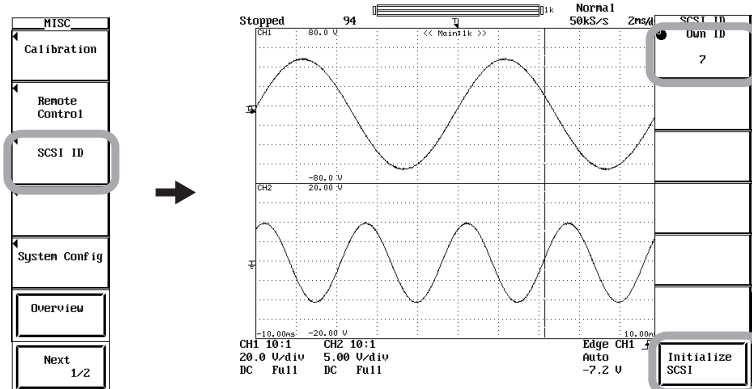

Explanation

The SCSI ID number is used to distinguish between the various devices connected to the SCSI chain. Make sure not to use duplicate ID numbers on any of the connected devices.

SCSI ID Numbers

Own ID (the ID of the DL7400) can be set in the range from 0 to 7. The default setting is 7.

Note

- Do not set the SCSI ID number of the external SCSI device to the same ID number as the DL7400.
- When changing the SCSI ID number, make sure to press the Initialize SCSI soft key.
- The SCSI ID numbers of external SCSI devices are automatically detected when the DL7400 is turned ON.
- If you change the ID number, be sure to execute Initialize SCSI to detect the new SCSI ID number.

12.5 Connecting USB Storage to the USB PERIPHERAL Interface

Specifications of the USB PERIPHERAL Interface

Item	Specifications
Connector type	USB type A connector (receptacle)
Electrical and mechanical	USB Rev. 1.1
Data rate	12 Mbps max.
Power supply	5 V, 500 mA* (per port)
Number of ports	2

* Devices with maximum consumption currents exceeding 100 mA cannot be connected to two ports at the same time.

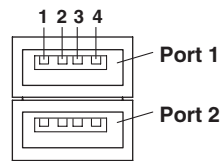

Pin No.	Signal Name
1	VBUS: +5 V
2	D- +Data
3	D+ -Data
4	GND: Ground

Connecting USB Storage

CAUTION

- Do not remove the USB storage device or turn the power to the instrument OFF while the device is being accessed. Doing so can destroy the data on the medium.
- While the USB storage device is being accessed, an “accessing” icon appears in the upper left part of the screen.

When connecting USB storage, directly connect the storage device to the instrument using a USB hub as shown below. You can connect the USB cable regardless of whether the power to the instrument is ON or OFF (supports hot-plugging). When the power switch is ON, the USB storage device is detected and enabled approximately six seconds after it is connected.

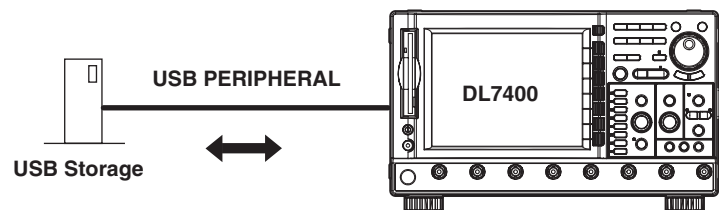

Compatible USB Storage

The instrument is compatible with USB mass storage class devices including hard disk drives, MO drives, and flash memory devices.

Note

- Do not connect USB devices other than a USB keyboard, USB mouse, USB printer, or USB storage to the USB PERIPHERAL connector.
- The instrument has two USB PERIPHERAL connectors, but two USB devices with maximum consumption currents exceeding 100 mA cannot be connected at the same time.

General Handling Precautions of USB Storage

For the general handling precautions of the USB storage device, read the instruction manual that came with the device.

12.6 Formatting the Storage Medium

CAUTION

- Do not remove the storage medium (disk) or turn OFF the power when the access indicator or icon of the storage medium is blinking. Doing so can damage the storage medium or destroy the data on the medium.
- If the DL7400 cannot recognize a formatted medium, format the disk again on the DL7400. Note that all the data on the storage medium are cleared when the storage medium is formatted. Be sure to back up important data beforehand.

Procedure

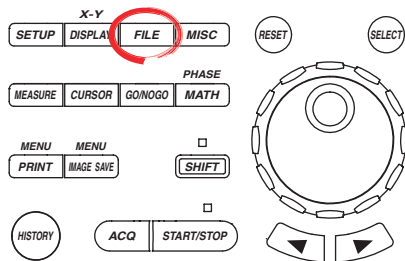

- To exit the menu during operation, press **ESC** located above the soft keys.
- In the procedural explanation below, the term *jog shuttle & SELECT* refers to the operation of selecting/setting items and entering values using the **jog shuttle** and **SELECT** and **RESET** keys. For details on this operation, see sections 4.1 or 4.2.
- For a description of the operation using a USB keyboard or a USB mouse, see section 4.3.

1. Press **FILE**. The FILE menu appears.
2. Press the **Utility** soft key to display the Utility menu and the File List window.

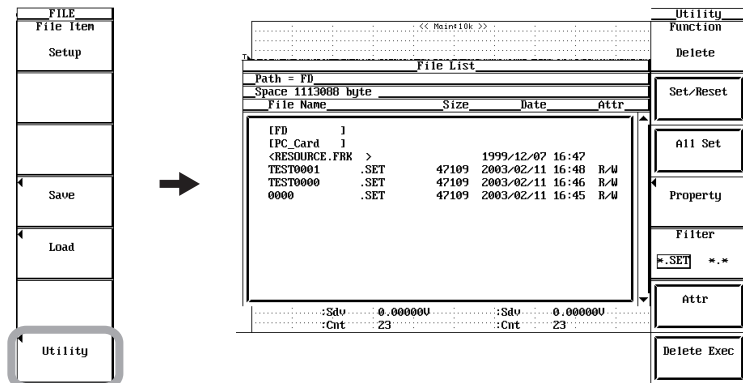

Selecting the Storage Medium to Be Formatted

3. Press the **Function** soft key. The Function menu appears.
4. Press the **Format** soft key. A media list is displayed in the File List window.
Net Drives cannot be formatted.
5. Turn **jog shuttle** to select the storage medium to be formatted.
If there are no external SCSI devices that are detected and only a floppy disk, a Zip disk, or a PC card is inserted, only FD, ZIP, or PC_Card appears.
If there is no external USB storage that is detected and only a floppy disk, or PC card is inserted, only FD or PC_Card appears.

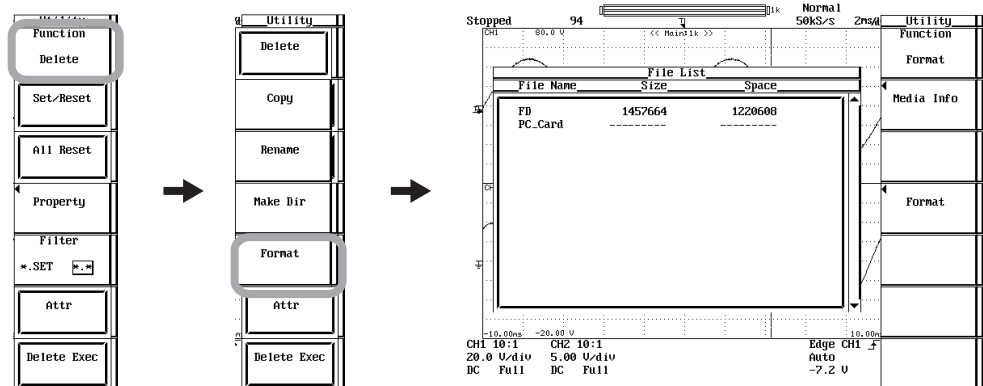

Selecting the Floppy Disk Format

6. Press the **Format** soft key. The Format menu appears.
Proceed to step 8.

Selecting the Zip Disk Format

6. Press the **Format** soft key. The Format menu appears.
No setting is necessary in formatting the Zip disk. Proceed to step 9.

Selecting the PC Card Format

6. Press the **Format** soft key. The Format menu appears.

Selecting the Number of Partitions

7. Turn **jog shuttle** to select 1 or 2.
Storage medium that is already partitioned can be selected and formatted as separate storage media (PC_Card1 or PC_Card2, for example), but the separate storage media cannot be partitioned further.

Selecting the SCSI Device Format

6. Press the **Format** soft key. The Format menu appears.

Selecting the Number of Partitions

7. Turn **jog shuttle** to select a value in the range of 1 to 3.
Storage medium that is already partitioned can be selected and formatted as separate storage media, but the separate storage media cannot be partitioned further.

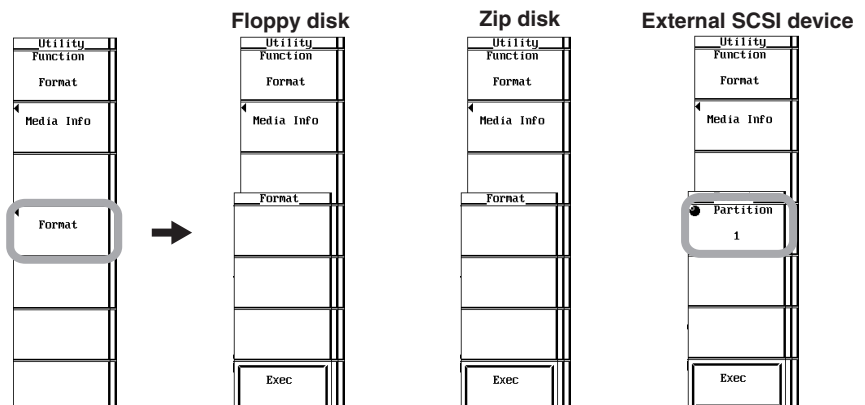

12.6 Formatting the Storage Medium

Selecting the USB Storage Format

6. Press the **Format** soft key. The Format menu appears.

Selecting the Number of Partitions

7. Turn the **jog shuttle** to select a value in the range of 1 to 3.
Storage media that are already partitioned can be selected and formatted as separate storage media, but the separate storage media cannot be partitioned further.

Executing (OK)/Aborting (Cancel) the Format Operation

8. Press the **Exec** soft key. The Alert dialog box opens.
9. Use **jog shuttle & SELECT** to select OK (execute) or Cancel.

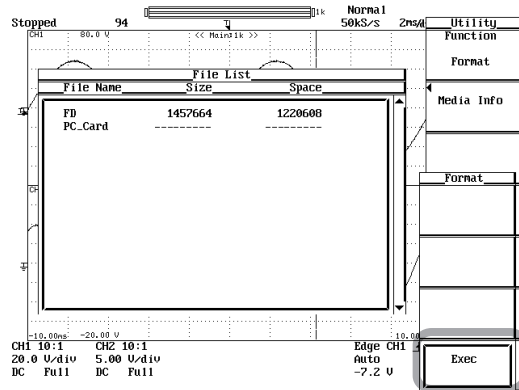

Viewing the Storage Media Information

Select the storage medium according to steps 1 to 5 on pages 12-10 and 12-11.

6. Press the **Media Info** soft key. The information about the storage medium that was selected in step 5 is displayed.

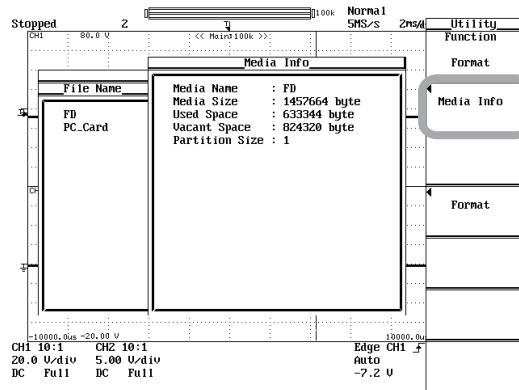

Explanation**Formatting a Floppy Disk**

When using a new floppy disk, you must format it. You can format the disk to 2HD 1.44M.

Formatting a Zip Disk

When using a new Zip disk, you need to format it.
The format of both the 250-MB and 100-MB Zip disks is FDISK 1 partition.

Formatting a PC Card

Flash ATA cards and compact flash using the PC card TYPE II adapter are formatted to IBM-compatible format.

Formatting an External SCSI Device

The formats of the disk that are connected via the SCSI (option) are shown in the table below.

MO	Semi-IBM format. Handled as a removable disk.
Zip	Hard disk format. Handled as a removable disk.
Formatting a Hard Disk	IBM-compatible format.

Initializing USB storage

USB storage are initialized in FAT format.

Number of Partitions (Excluding Removable Disks)

You can set partitions on external SCSI devices, USB storage devices, and PC cards. However, partitions cannot be specified on external SCSI devices and USB storage devices handled as removable disks. In addition, a storage medium that is already partitioned can be selected and formatted as a separate storage medium, but the separate storage medium cannot be partitioned further. On external SCSI devices and USB storage devices, you can select 1 to 3 partitions; on PC cards, you can select 1 or 2 partitions.

12.6 Formatting the Storage Medium

Media Information

Lists the information about the selected medium.

Media Name	Name of the medium.
Media Size	Total size.
Used Space	Size of the used area.
Vacant Space	Size of the free area.
Partition Size	Number of partitions.
Vendor Name	Maker name (only on external SCSI devices and USB storage devices)
Product Name	Product name (only on external SCSI devices and USB storage devices)

Note

- If you format a storage medium that has data stored on it, all of the stored data are cleared. Use caution when formatting a storage medium.
 - It takes approximately a minute and a half to format a floppy disk.
 - It takes approximately 10 seconds to format a 250-MB Zip disk.
 - It takes a few seconds to format a PC card.
 - You cannot format a floppy disk if the write-protect is ON.
 - Do not format a disk while the DL7400 and a PC is connected via a SCSI cable.
 - Floppy disks that are formatted to formats other than those listed in this section cannot be used.
 - If an error message is displayed after the format operation, the floppy disk may be damaged.
 - You can use floppy disks that are formatted on a PC under MS-DOS.
 - This function cannot be used when using the FTP server function, FTP client function, the LPR client function, the LPR client function, or Web server function.
-

12.7 Saving/Loading the Setup Data

CAUTION

Do not remove the storage medium (disk) or turn OFF the power when the access indicator or icon of the storage medium is blinking. Doing so can damage the storage medium or destroy the data on the medium.

Procedure

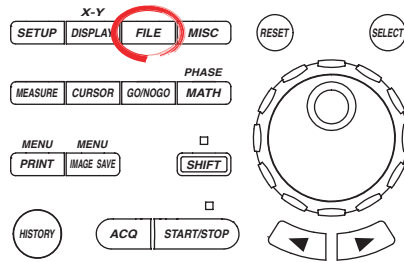

- To exit the menu during operation, press **ESC** located above the soft keys.
- In the procedural explanation below, the term *jog shuttle & SELECT* refers to the operation of selecting/setting items and entering values using the **jog shuttle** and **SELECT** and **RESET** keys. For details on this operation, see sections 4.1 or 4.2.
- For a description of the operation using a USB keyboard or a USB mouse, see section 4.3.

1. Press **FILE**. The FILE menu appears.
2. Press the **File Item** soft key. The File Item menu appears.
3. Press the **Setup** soft key.

Saving the Setup Data

Selecting the Save Destination Medium

4. Press the **Save** soft key. The Save menu appears.
5. Press the **File List** soft key. The File List window appears.
6. Use **jog shuttle & SELECT** to select the save destination medium (indicated by brackets).

Selecting the Save Destination Directory

(Perform this operation when directories are present on the medium.)

7. Use **jog shuttle & SELECT** to select the save destination directory (indicated by < >). The selected medium/directory is displayed in "Path=....." located above and to the left of the File List window. Select <..> to move to the parent directory.

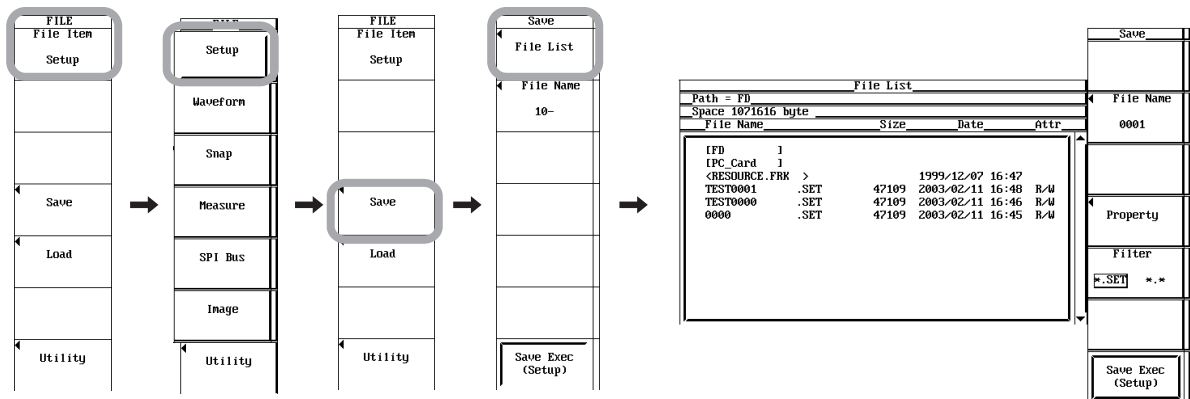

Setting the File Name and Comment

8. Press the **File Name** soft key. The File Name & Comment dialog box opens.
9. Use **jog shuttle & SELECT** to set the auto naming function.
 - If you select ON, the auto naming function is enabled.
 - If you select OFF, the auto naming function is disabled.
10. Use **jog shuttle & SELECT** to call up the keyboard and set the file name or comment.
 - Enter the file name using up to 14 characters.
 - Enter the comment using up to 25 characters.
11. Press **ESC**. The File Name & Comment dialog box closes.

Executing the Save Operation

12. Press the **Save Exec** soft key. The data is saved to the directory indicated by Path=..... At the same time, the Save Exec soft key changes to the Abort soft key. While the data is being saved, the  icon is displayed at the upper left corner of the screen.

Aborting the Save Operation

13. Press the **Abort** soft key. The save operation is aborted. At the same time, the Abort soft key changes to the Save Exec soft key.

Specifying the File to Be Displayed in the File List Window and Viewing File Properties

14. On the screen showing the File List window, press the **Filter** soft key to select *.SET or *.*.
 - If you select *.SET, only setup data files are displayed.
 - If you select *.* , all the files in the directory are displayed.
15. Turn **jog shuttle** to select the files in the File List window.
16. Press the **Property** soft key. Information about the selected file is displayed.
17. Press **ESC**. The window showing the information closes.

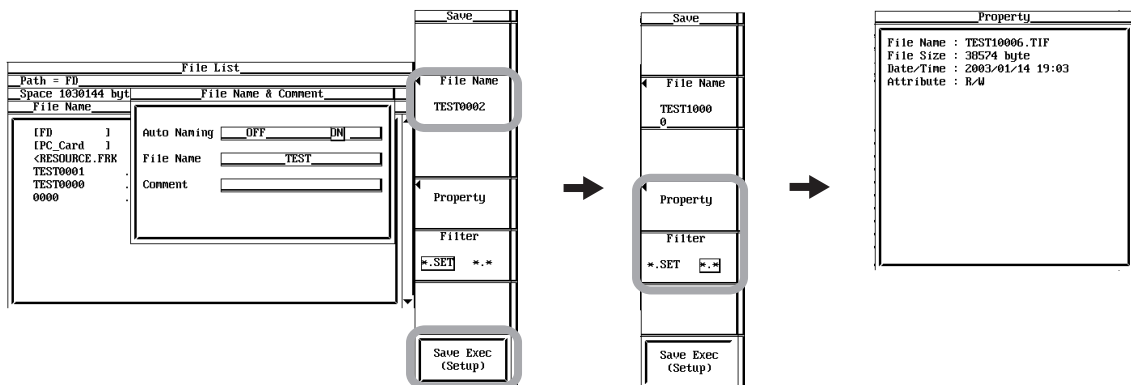

Loading the Setup Data

- Press the **Load** soft key. The Load menu and the File List window appear.

Selecting the Load Source Medium/Directory

- The procedure is the same as steps 6 and 7 on page 12-15.

Selecting the File to Be Loaded

- Turn **jog shuttle** to select a file.

Executing the Load Operation

- Press the **Load Exec** soft key. The selected file is read from the directory indicated in Path=..... At the same time, the Load Exec soft key changes to the Abort soft key.

Aborting the Load Operation

- Press the **Abort** soft key. The load operation is aborted. At the same time, the Abort soft key changes to a Load Exec soft key.

Specifying the File to Be Displayed in the File List Window and Viewing File Properties

- The procedure is the same as steps 14 to 16 on page 12-16.

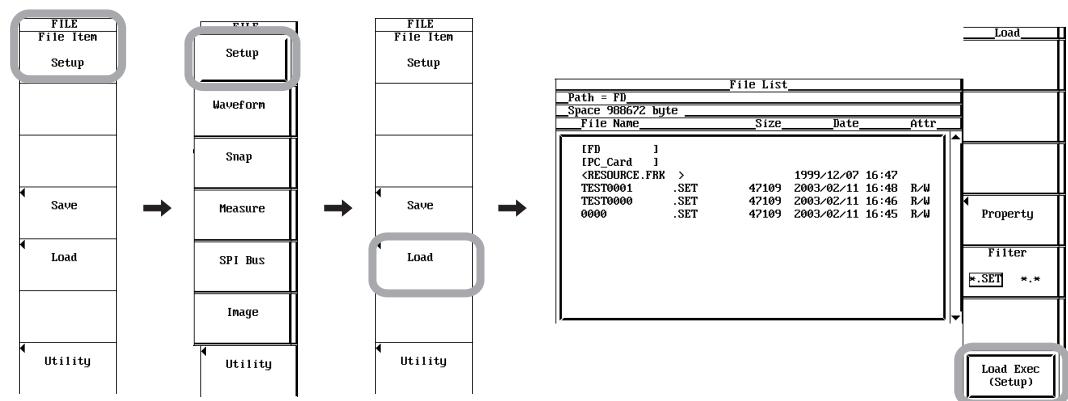

Explanation

Setup Data That Are Saved

The setup data existing at the time the store operation is executed can be saved. However, setup data such as the date/time, communications, and SCSI ID numbers is not saved.

Data Size

The size of the setup data is approximately 47 KB. However, if GO/NO-GO determination is performed using zones (see section 10.9), 4 KB of data is added for each registered zone.

Storage Medium and Directory

Storage media to and from which saving and loading are possible are displayed on the File List window.

Display Examples of Storage Media

FD	Floppy disk
ZIP	Zip disk
PC_Card	PC card
SCSI5	SCSI device with the ID number set to 5*
SCSI5-1	Partition 1 of a SCSI device whose ID number is 5*
NetWork	Network drive (when the Ethernet interface option is installed)
USB	USB storage

* When a SCSI device whose ID number is 5 is connected

Auto Naming

When Auto Naming is turned ON, files with a four digit number from 0000 to 2499 are automatically created when saving the data. You can specify a common name (up to ten characters, specified through Filename) that is placed before the number.

File Name and Comment

- A file name must be assigned. Comments are optional.
- You cannot save data to a file name that already exists in the same directory (overwriting not allowed).

Number and types of characters that can be used

Item	Number of Characters	Characters That Can Be Used
File name	1 to 14 characters	0 to 9, A to Z, %, _, (,), -
Comment	0 to 25 characters	All characters (including spaces)

Extension

The .SET extension is automatically added to the file name.

Specifying the File to Be Displayed on the File List Window

Specify the type of files to be displayed.

*.SET
Displays only setup data files.

.
Displays all the files in the directory.

Properties

Displays the following information about the selected file: the name, extension, the file size, the date the file was saved, the attribute, the comment, etc.

Note

-
- An error occurs if a key other than the Abort key is pressed while saving or loading a file.
 - Saving and Loading is not possible while waveform acquisition is in progress. Press the START/STOP key to stop the acquisition first.
 - The number of directories and files that can be displayed in the file list is 2500. If the number of directories and files in a directory exceeds 2500, the file list randomly displays 2500 of the directories and files.
 - If you change the extension of the file (using a PC, for example), the file can no longer be loaded.
 - Files that do not have an archive attribute are not displayed in the File List window. Do not remove the archive attribute of the files saved by the DL7400 using your PC.
 - Up to 42 characters can be displayed in the path. If 42 characters are exceeded, “...” is displayed at the end of the characters.
 - File names are not case-sensitive. Comments are case-sensitive. In addition, the following file names cannot be used due to limitations of MS-DOS.
AUX, CON, PRN, NUL, CLOCK, COM1 to COM9, and LPT1 to LPT9
 - If the setup data that is saved to a file are loaded, the settings of the menus and dialog boxes are changed to the loaded information and cannot be undone. It is recommended that you first save the current setup data and then load the setup data from a file.
 - Setup data such as the date/time, communications, and SCSI ID numbers is not saved. Therefore, loading setup data from a file will not change these settings.
 - This function cannot be used when using the FTP server function, FTP client function, the LPR client function, or the Web server function.
-

12.8 Saving/Loading the Waveform Data

CAUTION

Do not remove the storage medium (disk) or turn OFF the power when the access indicator or icon of the storage medium is blinking. Doing so can damage the storage medium or destroy the data on the medium.

Procedure

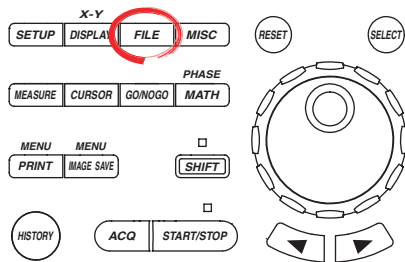

- To exit the menu operation, press **ESC** located above the soft keys.
- In the procedural explanation below, the term *jog shuttle & SELECT* refers to the operation of selecting/setting items and entering values using the **jog shuttle** and **SELECT** and **RESET** keys. For details on this operation, see sections 4.1 or 4.2.
- For a description of the operation using a USB keyboard or a USB mouse, see section 4.3.

1. Press **FILE**. The FILE menu appears.
2. Press the **File Item** soft key. The File Item menu appears.
3. Press the **Waveform** soft key.

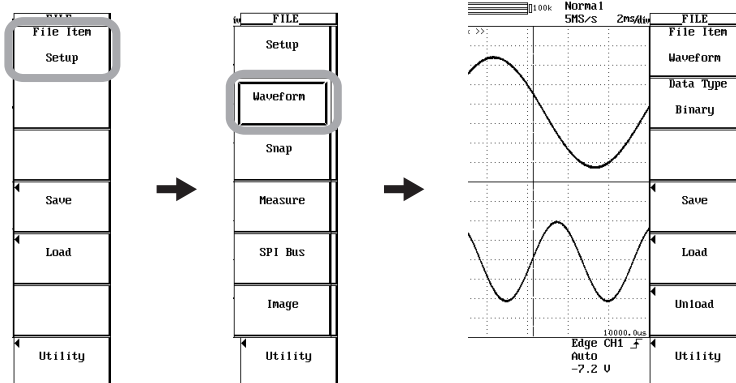

Saving the Waveform Data

Selecting the Data Type

4. Press the **Data Type** soft key. The Data Type menu appears.
5. Press the **Binary**, **ASCII**, or **Float** soft key to select the data type.
Only the data saved in binary can be loaded (as described later).

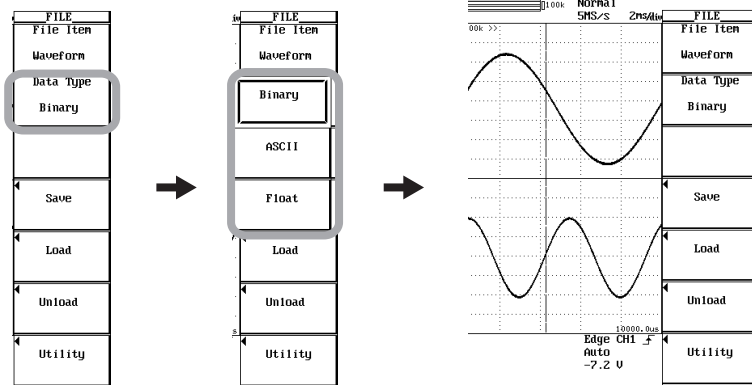

Selecting the Waveform to Be Saved

6. Press the **Save** soft key. The Save menu appears.
7. Press the **Trace** soft key. The Trace menu appears.
8. Press the channel soft key to select the waveform to be saved. If you select All, all the channels are saved.

Selecting the Range of the Waveform to Be Saved

9. Press the **Range** soft key. The Range menu appears.
10. Press one of the soft keys **Main** to **Z1&Z2** to select the range of the waveform to be saved.
11. Press the **History** soft key to select whether to save all the data in the history memory (All) or save only the selected waveform (One).
If you select All after searching the history memory data, only the waveforms that are found are saved.

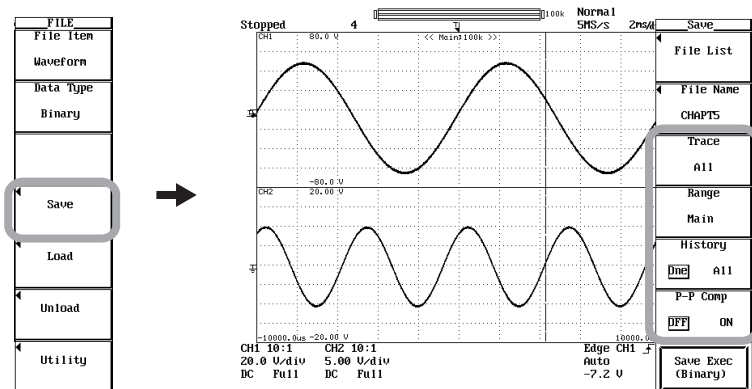

Saving the Waveform by Compressing the Data

12. Press the **P-P Comp** soft key to select ON or OFF.
 - If you select ON, the data is compressed and saved.
 - If you select OFF, the data is saved without compression.
 - If P-P Comp is turned ON when saving waveform data, only the maximum and minimum values of the multiple data points existing at the same time position are saved. Consequently, the file size is reduced.

12.8 Saving/Loading the Waveform Data

Selecting the Save Destination Medium/Directory

13. Press the **File List** soft key. The File List window appears.
14. Use **jog shuttle & SELECT** to select the save destination medium (indicated by brackets).

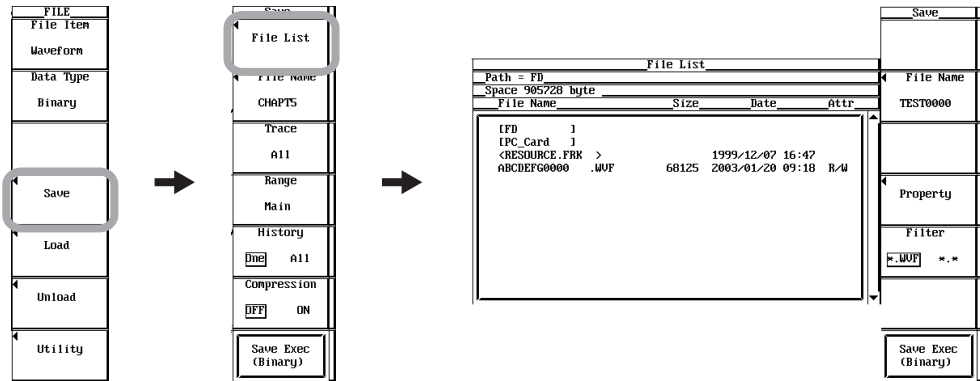

Selecting the Save Destination Directory

(Perform this operation when directories are present on the medium.)

15. Use **jog shuttle & SELECT** to select the save destination directory (indicated by < >). The selected medium/directory is displayed in "Path=....." located in the upper-left of the File List window. Select <..> to move to the parent directory.

Setting the File Name and Comment

16. Press the **File Name** soft key. The File Name & Comment dialog box opens.

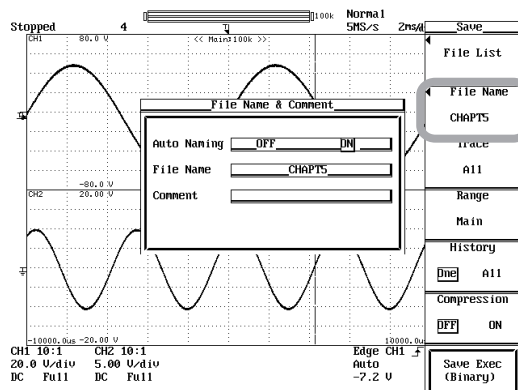

17. Use **jog shuttle & SELECT** to set the auto naming function.
 - If you select ON, the auto naming function is enabled.
 - If you select OFF, the auto naming function is disabled.
18. Use **jog shuttle & SELECT** to call up the keyboard and set the file name or comment.
 - Enter the file name using up to 14 characters.
 - Enter comment using up to 25 characters.
19. Press **ESC**. The File Name & Comment dialog box closes.

Executing the Save Operation

20. Press the **Save Exec** soft key. The data is saved to the directory indicated by Path=..... At the same time, the Save Exec soft key changes to the Abort soft key. While the data is being saved, the  icon is displayed at the upper left corner of the screen.

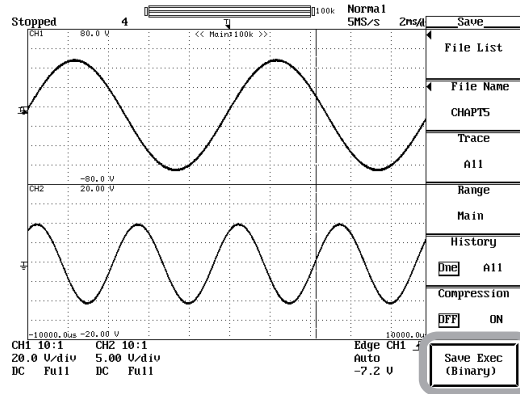

Aborting the Save Operation

21. Press the **Abort** soft key. The save operation is aborted. At the same time, the Abort soft key changes to the Save Exec soft key.

Specifying the File to Be Displayed in the File List Window and Viewing File Properties

22. On the screen showing the File List window, press the **Filter** soft key to select *.extension or *.*.
 - If you select *.extension (WVF, CSV, or FLD), only the files that have the same file format as the file being saved are displayed.
 - If you select *.* , all the files in the directory are displayed.
23. Turn **jog shuttle** to select the files in the File List window.
24. Press the **Property** soft key. Information about the selected file is displayed.
25. Press **ESC**. The window showing the information closes.

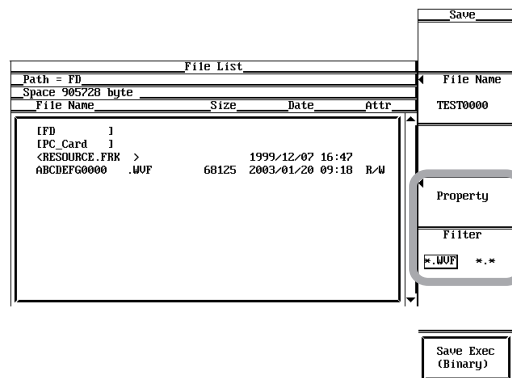

Loading the Waveform Data

Set the data type to Binary. For the setup procedure, see steps 4 and 5 on page 12-21.

6. Press the **Load** soft key. The Load menu and the File List window appear.

Selecting the Load Source Medium/Directory

7. The procedure is the same as steps 14 and 15 on page 12-22.

Selecting the File to Be Loaded

8. Turn **jog shuttle** to select a file.

Executing the Load Operation

9. Press the **Load Exec** soft key. The selected file is read from the directory indicated in Path=..... At the same time, the Load Exec soft key changes to the Abort soft key.

Aborting the Load Operation

10. Press the **Abort** soft key. The load operation is aborted. At the same time, the Abort soft key changes to the Load Exec soft key.

Specifying the File to Be Displayed in the File List Window and Viewing File Properties

11. The procedure is the same as steps 22 to 25 on page 12-23.

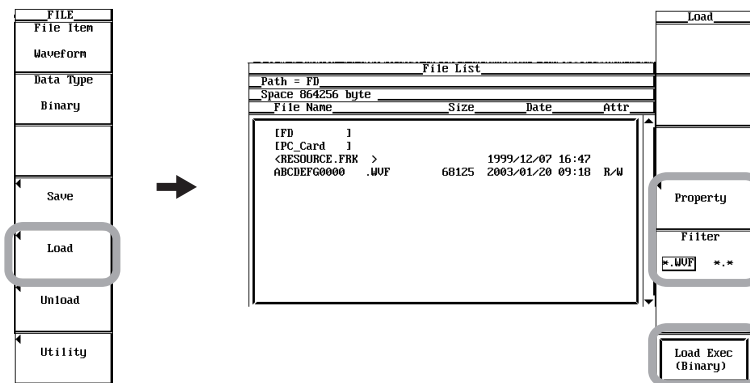

Unloading the Waveform Data

6. After step 5 of page 12-21, press the **Unload** soft key. The Unload menu is displayed.
7. Press the **Trace** soft key. The Trace menu appears.
8. Press the **All, CH1 to CH8(4), Math1, Math2, Pod A, or Pod B** soft key to select the waveform data to be unloaded.
 - On the DL7440, you can select from All, CH1 to CH4, Math1, Math2, Pod A, and Pod B. Math1, Math2, Pod A, and Pod B appear when you press the Next (1/2) soft key.
 - On the DL7480, you can select from All, CH1 to CH8, Math1, Math2, Pod A, and Pod B. CH5, CH6, CH7, CH8, and Math1 appear when you press the To Page 2 soft key. Math2, Pod A, and Pod B appear when you press the To Page 3 soft key.
 - If you select All, all the channels are unloaded.
9. Press the **Unload Exec** soft key. The unload operation is executed.

Explanation**Data Type and Extension****Binary**

- The sampled data in the acquisition memory is saved in binary format.
- The data that is saved can be loaded to display the waveform and compute numeric data.
- A header file that is used when analyzing the waveform on a PC is automatically created. The header file cannot be opened on the DL7400. For details on the header file format, see appendix 3.
- The extension is .WVF. The extension of the header file name is .HDR.
- When saving waveform data in binary format, a header file is automatically created with the extension .HDR. When the DL7400 is used to copy, delete, change the names of, or change the file attribute of waveform data files (files with .WVF extension), the header files are automatically updated to reflect the changes. Do not delete only the header file or only the waveform data file, as this may cause a system malfunction.

ASCII

- The units of the sampled data in the acquisition memory are converted per the specified range and saved in ASCII format. The data can be used to analyze the waveform on a PC.
- The file cannot be loaded into the DL7400.
- The extension is .CSV.

Float

- The units of the sampled data in the acquisition memory are converted per the specified range and saved in 32-bit floating format. The data can be used to analyze the waveform on a PC.
- The order of the data is little-endian (Intel format).
- The file cannot be loaded into the DL7400.
- The extension is .FLD.

Data Size

The following table shows the data size when the record length is set to 100 kW, waveform data of CH1 to CH4 are saved, MATH1 and MATH2 are turned OFF, and using history waveform 1 condition.

Data Type	Extension	Data Size (Bytes)
Binary	.WVF	Approx. 850 K $((100 \text{ kW} + 32) \times 4 \text{ channels} \times \text{the number of history waveforms} \times 2 + 46 \text{ K})$
	.HDR	Approx. 2 K (approx. 3 K when Math1 and Math2 are ON)
ASCII	.CSV	4 to 5 MB
Float	.FLD	Approx. 1.6 M $((100 \text{ kW} + 32) \times 4) \times \text{the number of history waveforms} \times 4)$

Waveforms to Be Saved

- You can save all the waveforms or the selected waveform from CH1 to CH8(4)*, Math1, Math2, Pod A, and Pod B.
* You can select up to CH4 or CH8 on the DL7440 and DL7480, respectively.
- The setup data including vertical axis, horizontal axis, and trigger of the waveform to be saved is also saved.
- For waveforms that are loaded using the history memory function, you can select whether to save all of the history waveforms or save just the current displayed waveform on the screen. You can also save only the results obtained by searching the history waveforms. For a description of searching the history waveforms, see section 10.2 or 10.3.
- For a description of snapshot waveforms, see section 12.9.

12.8 Saving/Loading the Waveform Data

Range of Waveform to Be Saved

You can select the range (area) of a waveform to be saved. Only the data that has been saved by selecting Binary in the aforementioned section "Data Type and Extension" can be loaded into the DL7400.

Main	The range of the normal (Main) waveform. It is the range defined by the display record length (range displayed on the screen).
Z1	The range of zoom waveform Z1.
Z2	The range of zoom waveform Z2.
Z1&Z2	The range of zoom waveforms Z1 and Z2.

Data Compression

- You can select whether to P-P compress the waveform data before saving.
- Power spectrum computation data cannot use P-P compression.

Storage Medium and Directory

Storage media which saving and loading are possible are displayed on the File List window.

Display Examples of Storage Media

FD	Floppy disk
ZIP	Zip disk
PC_Card	PC card
SCSI5	SCSI device with the ID number set to 5*
SCSI5-1	Partition 1 of a SCSI device whose ID number is 1*
NetWork	Network drive (when the Ethernet interface option is installed)
USB	USB storage

* When a SCSI device whose ID number is 5 is connected

Auto Naming

When Auto Naming is turned ON, files with a four digit number from 0000 to 2499 (0000 to 1199 for binary format) are automatically created when saving the data. You can specify a common name (up to ten characters, specified through Filename) that is placed before the number.

File Name and Comment

- A file name must be assigned. Comments are optional.
- You cannot save to a file name that already exists in the same directory (overwriting not allowed).

Number and types of characters that can be used

Item	Number of Characters	Characters That Can Be Used
File Name	1 to 14 characters	0 to 9, A to Z, %, _, (,), -
Comment	0 to 25 characters	All characters (including spaces)

Specifying the File to Be Displayed on the File List Window

Specify the type of files to be displayed.

*.WVF, *.CSV, and *.FLD

Displays only the files that have the same file format as the file being saved.

.

Displays all the files in the directory.

Properties

Displays the following information about the selected file: the name, extension, the file size, the date the file was saved, the attribute, the comment, etc.

Unload

When waveform data is loaded and displayed, newly acquired waveforms are not displayed even when waveform acquisition is started. To display the newly acquired waveforms, you must unload the waveform data that has been loaded into the respective channel.

Note

- An error occurs if a key other than the Abort key is pressed while saving or loading a file.
- Saving and Loading is not possible while waveform acquisition is in progress.
- If you change the extension of the file (using a PC, for example), the file can no longer be loaded.
- Files that do not have an archive attribute are not displayed in the File List window. Do not remove the archive attribute of the files saved by the DL7400 using your PC.
- Up to 42 characters can be displayed in the path.
- File names are not case-sensitive. Comments are case-sensitive. In addition, the following file names cannot be used due to limitations of MS-DOS. AAUX, CON, PRN, NUL, CLOCK, COM1 to COM9, and LPT1 to LPT9
- The waveform data loaded from a file overwrites the waveform data in the acquisition memory. Once the memory is overwritten, the old data cannot be recovered. It is recommended that the current waveform data be saved before loading data from a file.
- Loaded waveforms are cleared only when Unload, Initialize, or Auto Setup is executed or when the waveform acquisition condition is changed.
- If the total number of files and directories exceed 2500 in a single directory, the file list is no longer displayed.
- This function cannot be used when using the FTP server function, FTP client function, the LPR client function, or the Web server function.

Data Format When Storing Multiple Records

When multiple records are stored (history waveforms, for example), the following data format is used.

ASCII Format: CR+LF is inserted between records.

```

<Header>
Measured data 1-1 of CH1, Measured data 1-1 of CH2, Measured data 1-1 of CH3, ... , [ CR+LF]
Measured data 1-2 of CH1, Measured data 1-2 of CH2, Measured data 1-2 of CH3, ... , [ CR+LF]
      .....
Measured data 1-m of CH1, Measured data 1-m of CH2, Measured data 1-m of CH3, ... , [ CR+LF]
[ CR+LF]
Measured data 2-1 of CH1, Measured data 2-1 of CH2, Measured data 2-1 of CH3, ... , [ CR+LF]
Measured data 2-2 of CH1, Measured data 2-2 of CH2, Measured data 2-2 of CH3, ... , [ CR+LF]
      .....
Measured data 2-n of CH1, Measured data 2-n of CH2, Measured data 2-n of CH3, [ CR+LF]
[ CR+LF]
      .....
  
```

Record 1

Record 2

Float Format: Stored in blocks of channels.

Measured data of record 1 of CH1
Measured data of record 2 of CH1
⋮
Measured data of record N of CH1
Measured data of record 1 of CH2
Measured data of record 2 of CH2
⋮
Measured data of record N of CH2
⋮

12.9 Saving/Loading the Snapshot Waveforms

CAUTION

Do not remove the storage medium (disk) or turn OFF the power when the access indicator or icon of the storage medium is blinking. Doing so can damage the storage medium or destroy the data on the medium.

Procedure

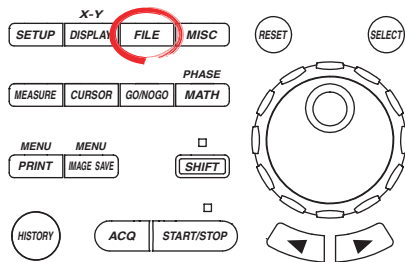

- To exit the menu during operation, press **ESC** located above the soft keys.
- In the procedural explanation below, the term *jog shuttle & SELECT* refers to the operation of selecting/setting items and entering values using the **jog shuttle** and **SELECT** and **RESET** keys. For details on this operation, see sections 4.1 or 4.2.
- For a description of the operation using a USB keyboard or a USB mouse, see section 4.3.

1. Press **FILE**. The FILE menu appears.
2. Press the **File Item** soft key. The File Item menu appears.
3. Press the **Snap** soft key.

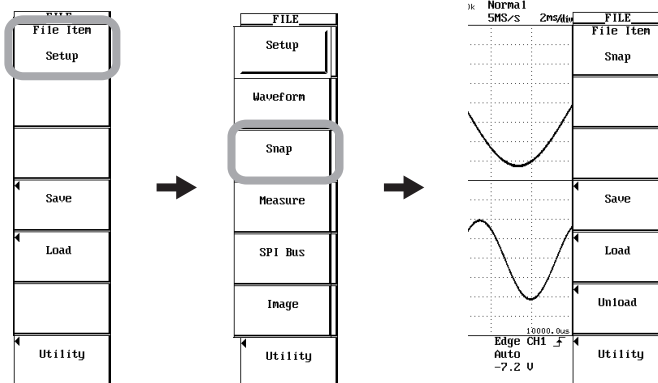

Saving Snapshot Waveforms

4. Press the **Save** soft key. The Save menu appears.

Selecting the Save Destination Medium/Directory

5. The procedure is the same as steps 13 to 15 on page 12-22.

Setting the File Name and Comment

6. The procedure is the same as steps 16 to 18 on page 12-22.

Executing the Save Operation

7. Press the **Save Exec** soft key. The data is saved to the directory indicated by Path=..... At the same time, the Save Exec soft key changes to the Abort soft key.

Aborting the Save Operation

8. Press the **Abort** soft key. The save operation is aborted. At the same time, the Abort soft key changes to the Save Exec soft key.

Specifying the File to Be Displayed in the File List Window and Viewing File Properties

9. The procedure is the same as steps 22 to 25 on page 12-23.

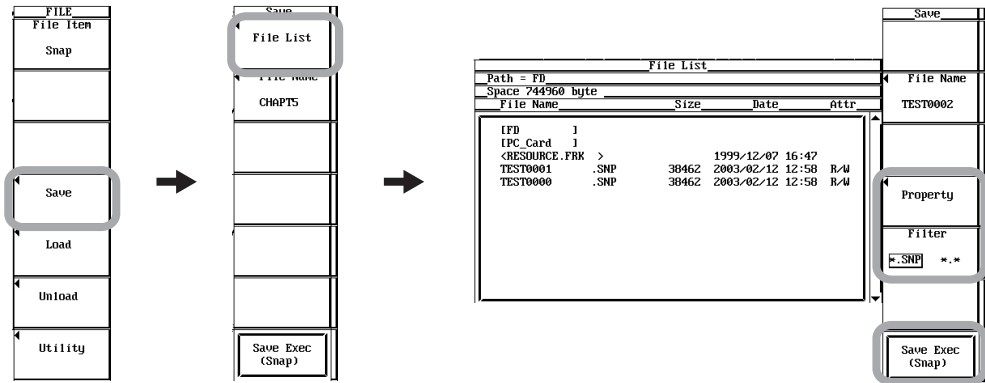

Loading Snapshot Waveforms

Select the snapshot waveform data according to steps 1 to 3 on page 12-28.

4. Press the **Load** soft key. The Load menu and the File List window appear.

Selecting the Load Source Medium/Directory

5. The procedure is the same as steps 14 and 15 on page 12-22.

Selecting the File to Be Loaded

6. Turn **jog shuttle** to select a file.

Selecting the Snapshot Waveform to Be Loaded

7. Press the **Destination** soft key. The Destination menu appears.
8. Press one of the soft keys **Snap1** to **Snap4** to select the load destination of the snapshot waveform.

Executing the Load Operation

9. Press the **Load Exec** soft key. The selected file is read from the directory indicated in Path=..... At the same time, the Load Exec soft key changes to the Abort soft key.

Aborting the Load Operation

10. Press the **Abort** soft key. The load operation is aborted. At the same time, the Abort soft key changes to the Load Exec soft key.

Specifying the File to Be Displayed in the File List Window and Viewing File Properties

11. The procedure is the same as steps 22 to 25 on page 12-23.

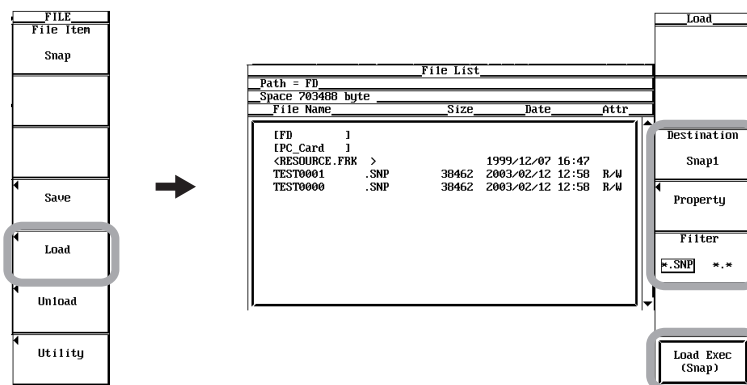

Clearing Waveforms

4. After step 3 of page 12-28, press the **Unload** soft key. The Unload menu is displayed.
5. Press the **Trace** soft key. The Trace menu appears.
6. Press the **All** or **Snap1** to **Snap4** soft key to select the load destination to be unloaded.
 - If you select All, all the load destinations are unloaded.
7. Press the **Unload Exec** soft key to clear the selected waveforms.

Explanation

You can take snapshots of the waveform and save the image to the file. You can also load the snapshot waveform.

Data Size

The size of the snapshot waveform data is approximately 40 KB.

Extension

The extension is .SNP.

The selection of the medium and directory, file name, comments, auto naming function, specification of the files to be displayed in the File List window, and properties are the same as those for saving/loading normal waveform data. For the explanation and procedure, see section 12.8.

Loading Snapshot Waveforms

Snapshot waveforms are loaded to the selected load destination from Snap1 to Snap4.

Clearing Waveforms

The loaded snapshot waveforms are cleared when Unload, Initialize, or Auto Setup is executed.

Note

This function cannot be used when using the FTP server function, FTP client function, the LPR client function, or the Web server function.

12.10 Saving the Results of the Automated Measurement of Waveform Parameters

CAUTION

Do not remove the storage medium (disk) or turn OFF the power when the access indicator or icon of the storage medium is blinking. Doing so can damage the storage medium or destroy the data on the medium.

Procedure

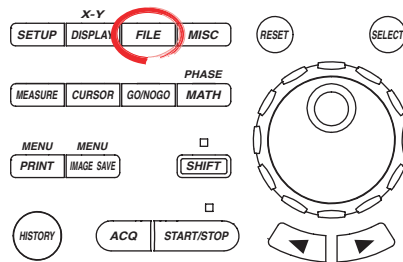

- To exit the menu during operation, press **ESC** located above the soft keys.
- In the procedural explanation below, the term *jog shuttle & SELECT* refers to the operation of selecting/setting items and entering values using the **jog shuttle** and **SELECT** and **RESET** keys. For details on this operation, see sections 4.1 or 4.2.
- For a description of the operation using a USB keyboard or a USB mouse, see section 4.3.

1. Press **FILE**. The FILE menu appears.
2. Press the **File Item** soft key. The File Item menu appears.
3. Press the **Measure** soft key.
4. Press the **Save** soft key. The Save menu appears.

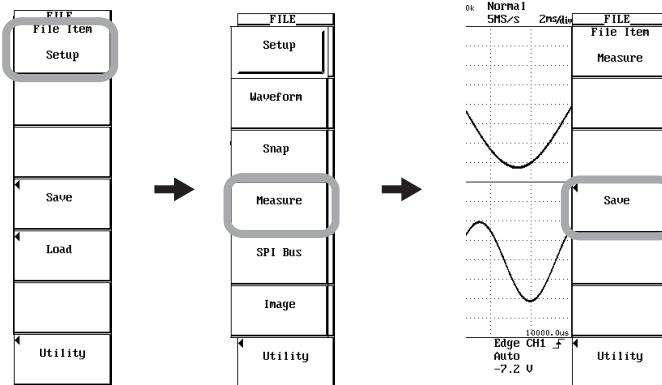

Selecting the Save Destination Medium/Directory

5. The procedure is the same as steps 13 to 15 on page 12-22.

Setting the File Name and Comment

6. The procedure is the same as steps 16 to 19 on page 12-22.

Executing the Save Operation

7. Press the **Save Exec** soft key. The data is saved to the directory indicated by Path=..... At the same time, the Save Exec soft key changes to the Abort soft key.

Aborting the Save Operation

8. Press the **Abort** soft key. The save operation is aborted. At the same time, the Abort soft key changes to the Save Exec soft key.

Specifying the File to Be Displayed in the File List Window and Viewing File Properties

9. The procedure is the same as steps 22 to 25 on page 12-23.

Explanation

The results of the automated measurement of waveform parameters can be saved to a file in CSV format (.csv extension) to a floppy disk, Zip disk, PC card, external SCSI device, or USB storage device. Data in CSV format is data in comma-separated format. The CSV file is one of the common data formats used to exchange data between spreadsheet and database applications.

- * The data that is saved is the measured results of the parameters that are specified in the automated measurement of waveform parameters.

Restrictions When Saving the Automated Measurement Values of Waveform Parameters

- Up to (24000/the number of measurement parameters that are turned ON) data points before the point at which the save operation is executed are saved. However, the data points that are saved are limited to those that are acquired after fixing T/div, V/div, and Measure settings.

- Output example

```
DL7400
      ,"CH1 P-P ", "CH1 Max ", "CH1 Avg ", "CH2 P-P ", "CH2 Max "
      ,"V", "V", "V", "V", "V"
Max, 3.708333E+02, 1.833333E+02, 1.439439E+00, 1.133333E+01, 5.750000E+00
Min, 3.625000E+02, 1.791667E+02, 9.124088E-01, 1.125000E+01, 5.583333E+00
Avg, 3.681818E+02, 1.821970E+02, 1.106889E+00, 1.129545E+01, 5.651515E+00
Sdv, 2.678435E+00, 1.855674E+00, 1.885480E-01, 4.149413E-02, 4.791330E-02
Cnt, 1.100000E+01, 1.100000E+01, 5.000000E+00, 1.100000E+01, 1.100000E+01
      ,3.708333E+02, 1.833333E+02, 1.439439E+00, 1.125000E+01, 5.583333E+00
      ,3.666667E+02, 1.791667E+02, 9.124088E-01, 1.133333E+01, 5.750000E+00
      ,3.666667E+02, 1.833333E+02, 9.507383E-01, 1.125000E+01, 5.583333E+00
      ,3.666667E+02, 1.791667E+02, 1.066977E+00, 1.125000E+01, 5.666667E+00
      ,3.708333E+02, 1.833333E+02, 1.164884E+00, 1.133333E+01, 5.666667E+00
```

For a description of the automated measurement of waveform parameters, see section 10.6.

Data Size

The data size can be derived from the following equation.

Data size = the number of measurement parameters × 15 × the number of history waveforms (bytes)

Extension

The extension is .CSV.

The selection of the medium, directory, file name, comments, auto naming function, specification of the files to be displayed in the File List window, and properties are the same as those for saving/loading normal waveform data. For the explanation and procedure, see section 12.8.

Note

This function cannot be used when using the FTP server function, FTP client function, the LPR client function, or the Web server function.

12.11 Saving the Detailed Analysis List of SPI Signals

CAUTION

Do not remove the storage medium (disk) or turn OFF the power when the access indicator or icon of the storage medium is blinking. Doing so can damage the storage medium or destroy the data on the medium.

Procedure

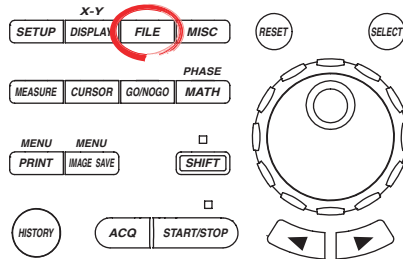

- To exit the menu during operation, press **ESC** located above the soft keys.
- In the procedural explanation below, the term *jog shuttle & SELECT* refers to the operation of selecting/setting items and entering values using the **jog shuttle** and **SELECT** and **RESET** keys. For details on this operation, see sections 4.1 or 4.2.
- For a description of the operation using a USB keyboard or a USB mouse, see section 4.3.

1. Press **FILE**. The FILE menu appears.
2. Press the **File Item** soft key. The File Item menu appears.
3. Press the **To Page 2** soft key.
4. Press the **SPI Bus** soft key.
Depending on the model, the SPI Bus item may appear under the File Item menu (Page No. (1/2)) without having to press the Top Page 2 soft key.
5. Press the **Save** soft key. The Save menu appears.

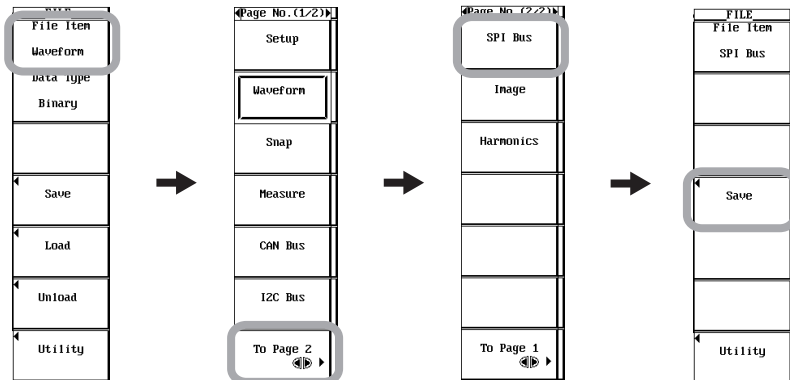

Selecting the Save Destination Medium/Directory

6. The procedure is the same as steps 13 to 15 on page 12-22.

Setting the File Name and Comment

7. The procedure is the same as steps 16 to 19 on page 12-22.

Executing the Save Operation

- Press the **Save Exec** soft key. The data is saved to the directory indicated by Path=..... At the same time, the Save Exec soft key changes to the Abort soft key.

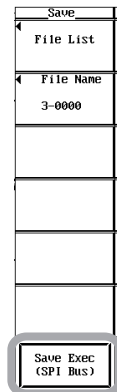

Aborting the Save Operation

- Press the **Abort** soft key. The save operation is aborted. At the same time, the Abort soft key changes to the Save Exec soft key.

Specifying the File to Be Displayed in the File List Window and Viewing File Properties

- The procedure is the same as steps 22 to 25 on page 12-23.

Explanation

The analysis results of SPI signals can be saved to a file in ASCII format. The contents of the detailed analysis list of the SPI signal are saved as-is to the file. The extension is .TXT. The file size is as follows:

$$\text{File size} = (\text{number of bytes per data point}^1 \times \text{number of analysis results}) + 44 \text{ bytes}^2$$

- The number of bytes per data varies depending on the data.
 - 40 bytes (Data2) minimum for analysis data without CS.
 - 44 bytes (CS) maximum for analysis data with multiple CSs and CS set to CH4.
- The data size of the title is 44 bytes.

[Save example]

No.	Time(ms)	Data1	Data2	CS
-7	-0.005	*00	*BB	
-6	-0.004	*00	*AA	
-5	-0.003	*00	*A9	
-4	-0.003	*00	*54	
-3	-0.002	*00	*55	
-2	-0.001	*0F	*7A	
-1	-0.001	*3F	*BF	
0	0.000	*C0	*57	
1	0.001	*40	*E5	
2	0.001	*03	*E7	
3	0.002	*80	*E9	
4	0.003	*40	*D5	
5	0.003	*08	*FE	
6	0.004	*00	*7A	

Precautions to Be Taken When Saving the Data

- The maximum number of files that can be saved when the auto naming function is ON is 1150.
- If the total number of files and directories exceed 2500 in a single directory, the contents of the File List box are no longer displayed.

12.12 Saving Screen Image Data

CAUTION

Do not remove the storage medium (disk) or turn OFF the power when the access indicator or icon of the storage medium is blinking. Doing so can damage the storage medium or destroy the data on the medium.

Procedure

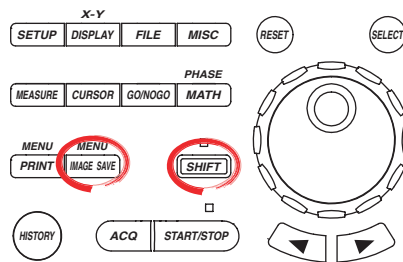

- To exit the menu during operation, press **ESC** located above the soft keys.
- In the procedural explanation below, the term *jog shuttle & SELECT* refers to the operation of selecting/setting items and entering values using the **jog shuttle** and **SELECT** and **RESET** keys. For details on this operation, see sections 4.1 or 4.2.
- For a description of the operation using a USB keyboard or a USB mouse, see section 4.3.

1. Press **SHIFT+IMAGE SAVE (MENU)**. The IMAGE menu appears.

Selecting the Data Format

2. Press the **Format** soft key. The Format menu appears.
3. Press the **TIFF, BMP, Post Script, PNG, or JPEG** soft key to select the data format.

Setting the Color Mode

(Selectable only when the data format is set to **TIFF, BMP, PNG, or JPEG** in step 3)

4. Press the **Color** soft key. The Color menu appears.
5. Press the **ON, ON (Revers)** (white background), **ON (Gray)** (grayscale), or **OFF** to select the color mode.

Setting the Compression Mode

(Selectable only when the data format is set to **BMP** in step 3 and the color mode is set to “**ON, ON (Revers)** or **ON (Gray)** in step 5)

5. Press the **Compression** soft key to select ON or OFF.

Setting Comments

5. Press the **Comment** soft key. A keyboard used to enter values and strings appears.
6. Use **jog shuttle & SELECT** to set the comment.
Enter comment using up to 25 characters.

Selecting the Save Destination Medium

7. Press the **File List** soft key. The save destination File List window appears.
8. Use **jog shuttle & SELECT** to select the save destination medium (indicated by brackets).

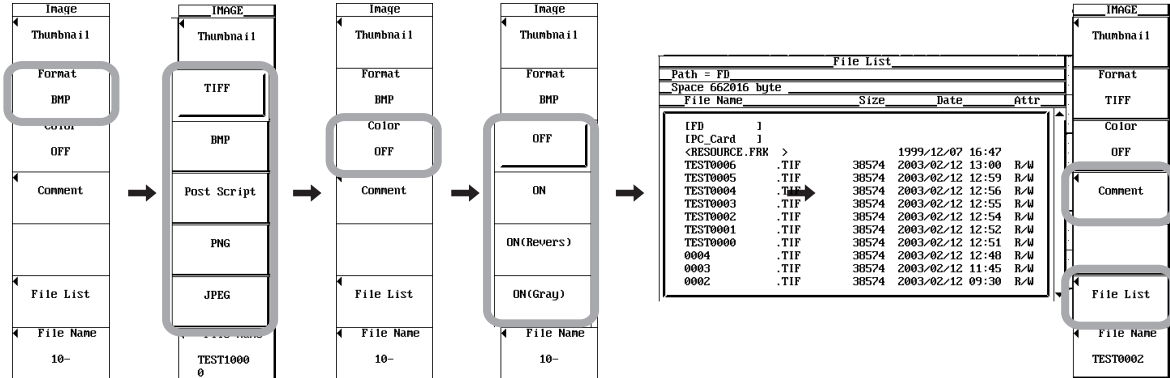

Selecting the Save Destination Directory

Perform this operation when directories are present on the medium.

9. Use **jog shuttle & SELECT** to select the save destination directory (indicated by <>). The selected medium/directory is displayed in “Path=.....” located in the upper-left of the File List window.
Select <..> to move to the parent directory.

Setting the File Name

10. Press the **File Name** soft key. The file name setup menu appears.
11. Use **jog shuttle & SELECT** to set the auto naming function.
 - If you select ON, the auto naming function is enabled.
 - If you select OFF, the auto naming function is disabled.
12. Use **jog shuttle & SELECT** to call up the keyboard and set the file name.
Enter the file name using up to 14 characters.

Executing/Aborting the Save Operation

13. Press **IMAGE SAVE**. The screen image data is saved to the storage medium. Pressing **IMAGE SAVE** again aborts the save operation. While the data is being saved, the  icon is displayed at the upper left corner of the screen.

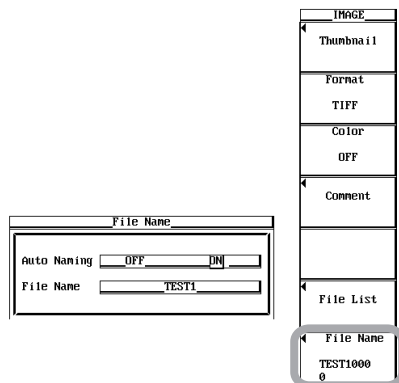

Note

Thumbnails of the saved screen image data can be displayed. For details, see section 12.13.

Explanation

The screen image data can be stored to a specified storage medium. You can select a storage medium of floppy disk, Zip disk, PC card, external SCSI device, or network drive (when the Ethernet interface option is installed). For details on saving data to the network drive, see section 13.3.

Data Format and Extension

Data in the following formats can be saved to a specified storage medium. The extension that is automatically attached and the data size (reference value) are indicated below.

Data Format	Extension	Data Size ¹
TIFF	*.TIF	Approx. 40 KB (Approx. 310 KB) ²
BMP	*.BMP	Approx. 40 KB (Approx. 310 KB) ²
Post Script	*.PS	Approx. 80 KB
PNG	*.PNG	Approx. 6 KB (Approx. 14 KB) ²
JPEG	*.JPG	Approx. 400 KB (Approx. 400 KB) ²

1 When color is OFF.

2 The file size inside the parentheses is for the case when color is ON.

Color Mode

You can select the color mode only when the data format is set to TIFF, BMP, PNG, or JPEG.

ON	Output using 256 colors.
ON(Revers)	Do not output the background of the screen in color.
ON(GRAY)	Output the data using a tint of 16 gray levels.
OFF	Output in black and white.

Compress Mode

When the output format is set to BMP, the data can be output by compressing using RLE. However, data is not compressed if the color is OFF.

Comment

A comment of up to 25 characters can be added to the lower section of the screen and saved. Comments are optional. All characters (including spaces) can be used.

Save Destination

The available storage medium is displayed in the File List window.

Display Examples of Storage Media

FD	Floppy disk
ZIP	Zip disk
PC_Card	PC card
SCSI5	SCSI device with the ID number set to 5*
SCSI5-1	Partition 1 of a SCSI device whose ID number is 1*
NetWork	Network drive (when the Ethernet interface option is installed)
USB	USB storage

* When a SCSI device whose ID number is 5 is connected

Floppy Disks, Zip Disks, PC Cards, and External SCSI Devices

The handling of the floppy disk, Zip disk, PC card, and external SCSI device are described in sections 12.2 and 12.3. For the formatting procedure, see section 12.6.

12.12 Saving Screen Image Data

File Name

Number of characters and types that can be used

Number of Characters	Characters That Can Be Used
1 to 14 characters	0 to 9, A to Z, %, _, (,)

Auto Naming

When Auto Naming is turned ON, files with a four digit number from 0000 to 2499 (0000 to 1249 for binary format) are automatically created when saving the data. You can specify a common name (up to ten characters, specified through Filename) that is placed before the number.

Reduced Image (Thumbnail) Data

If a screen image data file (a file with .TIF, .BMP, .PS, .PNG, or .JPG extension) is saved to the directory selected using File List on the IMAGE SAVE menu, data separate from the screen image data used for thumbnail display is created along with the screen image data itself. The extension of thumbnail data varies depending on the data format of the original screen image data as follows:

TIFF file	.TTD
BMP file	.BTD
PS file	.PTD
PNG file	.NTD
JPEG file	.JTD

The data size is approximately 2 to 6 KB for all 5 file types. For a description of the thumbnail display, see section 12.13.

Note

- The maximum number of files that can be saved when auto naming is enabled is 2500.
- If the total number of files and directories exceed 2500 in a single directory, the file list is no longer displayed.

12.13 Displaying Thumbnails of the Saved Screen Image Data

CAUTION

Do not remove the storage medium (disk) or turn OFF the power when the access indicator or icon of the storage medium is blinking. Doing so can damage the storage medium or destroy the data on the medium.

Procedure

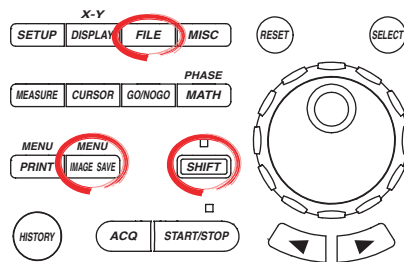

- To exit the menu during operation, press **ESC** located above the soft keys.
- In the procedural explanation below, the term *jog shuttle & SELECT* refers to the operation of selecting/setting items and entering values using the **jog shuttle** and **SELECT** and **RESET** keys. For details on this operation, see sections 4.1 or 4.2.
- For a description of the operation using a USB keyboard or a USB mouse, see section 4.3.

Displaying Thumbnails from the IMAGE Menu

1. Press **SHIFT+IMAGE SAVE (MENU)**. The IMAGE menu appears.
2. Press the **Format** soft key. The Format menu appears.
3. Press the **TIFF, BMP, Post Script, PNG, or JPEG** soft key to select the data format of the screen image data whose thumbnail is to be displayed.

Displaying the Thumbnails of the Specified Screen Image Data

4. Press the **File List** soft key. The File List window appears.
5. Use **jog shuttle & SELECT** to select the screen image data file in the File List window. The thumbnail of the selected screen image data file is displayed at the upper right section of the File List window. To clear the thumbnail, turn the **jog shuttle**.

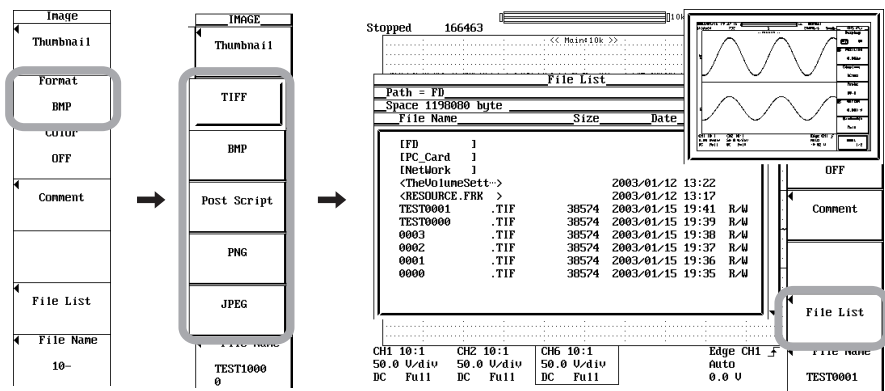

Note

- If the selected screen image data file does not have data (file) for thumbnail display, an error message appears.
- You can press **ESC** to clear the thumbnail, but in this case, the File List window is also cleared. To clear only the thumbnail display, turn the jog shuttle.

12.13 Displaying Thumbnails of the Saved Screen Image Data

Listing the Thumbnails of Specified Data Format

4. Press the **File List** soft key. The File List window appears.
5. Turn **jog shuttle** to select the directory containing the thumbnails you wish to display.
6. Press **ESC** to close the File List window.
7. Press the **Thumbnail** soft key. The thumbnails of the screen image data having the format specified in step 3 are displayed (4 thumbnails (2 × 2) in the waveform display area).
8. If there are more than 5 thumbnails, you can scroll the screen using the **jog shuttle**. To scroll the files upward, turn the jog shuttle counter-clockwise. To scroll the files downward, turn the jog shuttle clockwise. The files scroll two files at a time.
9. To clear the list of thumbnails, press **ESC**.

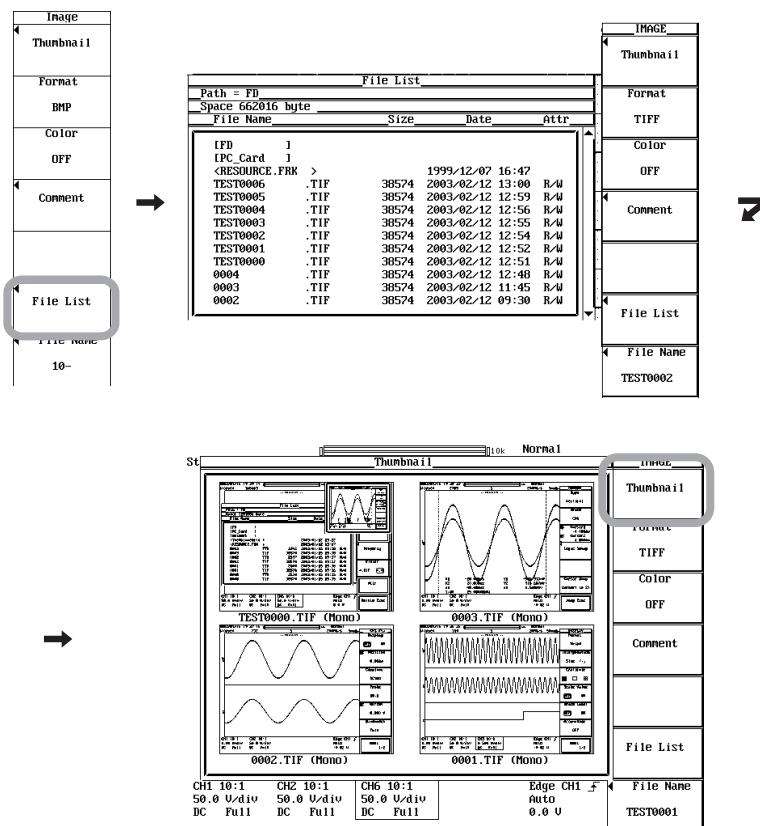

Displaying Thumbnails from the FILE Menu

1. Press **FILE**. The FILE menu appears.
2. Press the **File Item** soft key. The File Item menu appears.
3. Press the **Image** soft key.
4. Press the **Format** soft key. The Format menu appears.
5. Press the **TIFF, BMP, Post Script, PNG, or JPEG** soft key to select the thumbnail format.
6. Press the **Utility** soft key. The Utility menu and the File List window appear.
7. Press the **Function** soft key. The Function menu appears.
8. Press the **Delete, Copy, Rename, or Make Dir** soft key.
 - Set Function to an item other than Format. If Function is set to Format, the screen image data files are not displayed.
9. Use **jog shuttle & SELECT** to select the screen image data file (file with .TIF, .BMP, .PS, .PNG, or .JPG extensions) on the File List window.
 - The thumbnail of the selected screen image data file is displayed at the upper right section of the File List window.
 - To clear the thumbnail, turn the **jog shuttle**.

Note

- If the selected screen image data file does not have data (file) for thumbnail display, an error message appears.
- You can press ESC to clear the thumbnail, but in this case, the File List window is also cleared. To clear only the thumbnail display, turn the jog shuttle.

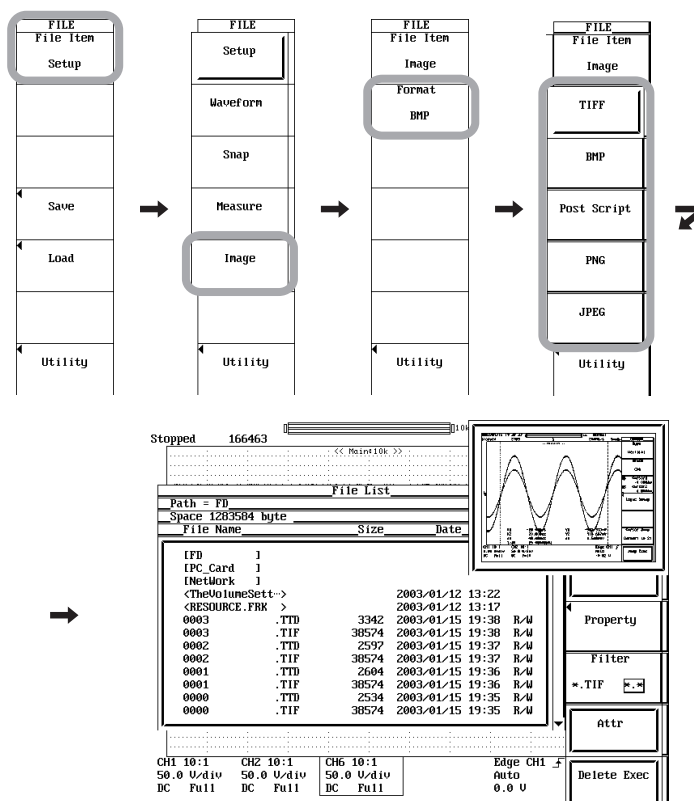

Explanation

Thumbnails of the screen image data that are saved on a storage medium can be displayed.

Thumbnail Display from the IMAGE Menu

Thumbnail Screen

Thumbnails are displayed for the screen image data files (files with .TIF, .BMP, .PS, .PNG, and .JPG extensions) in the directory selected using File List in the IMAGE menu. The data used to display thumbnails is separate from the screen image data, but is created simultaneously when the screen image data is created. The extension of thumbnail data varies depending on the data format of the original screen image data as follows:

TIFF file	.TTD
BMP file	.BTD
PS file	.PTD
PNG file	.NTD
JPEG file	.JTD

The data size is approximately 2 to 6 KB for all formats.

Thumbnail Items

The following three items are displayed.

- Thumbnail of the waveform area
- File name
- Color information

Thumbnail Display Format

The number of files displayed on the thumbnail screen (the number of thumbnails displayed in the waveform area) is 4. The display order is the same as the order for displaying files in the File List window. In addition, the files are displayed from left to right and top to bottom.

Scrolling the Thumbnail Screen

If the number of thumbnails exceeds the maximum number of thumbnails that can be displayed (4), the thumbnail screen can be scrolled one row (two thumbnails) at a time. To scroll the files upward, turn the jog shuttle counter-clockwise. To scroll the files downward, turn the jog shuttle clockwise.

Thumbnails on the File List

When you select a screen image data file on the File List, the thumbnail of the screen image data is displayed at the upper right section of the File List. The file name is not displayed on the thumbnail screen on the File List.

Displaying Thumbnails from the FILE Menu

When you select a screen image data file on the File List, the thumbnail of the screen image data is displayed at the upper right section of the File List. The file name is not displayed on the thumbnail screen on the File List.

Note

The screen image data and thumbnail data are saved in pairs of files. For example, if you set the data format to BMP, the following two types of files are saved.

- 0000.BMP (screen image data)
- 0000.BTD (thumbnail data)

If you specify “*.*” for the files to be displayed (Filter) on the File List and manipulate individual files (Delete, Rename, or Copy), the thumbnail display function can no longer be used.

12.14 Changing the File Attributes and Deleting Files

CAUTION

Do not remove the storage medium (disk) or turn OFF the power when the access indicator or icon of the storage medium is blinking. Doing so can damage the storage medium or destroy the data on the medium.

Procedure

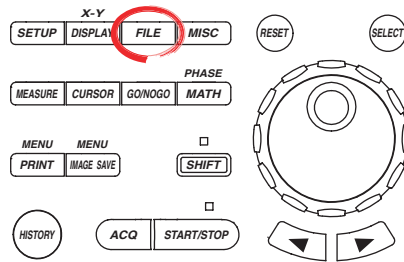

- To exit the menu during operation, press **ESC** located above the soft keys.
- In the procedural explanation below, the term *jog shuttle & SELECT* refers to the operation of selecting/setting items and entering values using the **jog shuttle** and **SELECT** and **RESET** keys. For details on this operation, see sections 4.1 or 4.2.
- For a description of the operation using a USB keyboard or a USB mouse, see section 4.3.

1. Press **FILE**. The FILE menu appears.
2. Press the **Utility** soft key. The Utility menu and the File List window appear.

Selecting the Storage Medium/Directory

3. The procedure is the same as steps 14 and 15 on page 12-22.

Changing the File Attribute

4. Turn **jog shuttle** to select a file.
5. Press the **Attr** soft key. The attribute of the selected file changes.

To delete a file, change the file attribute to R/W (read/write)

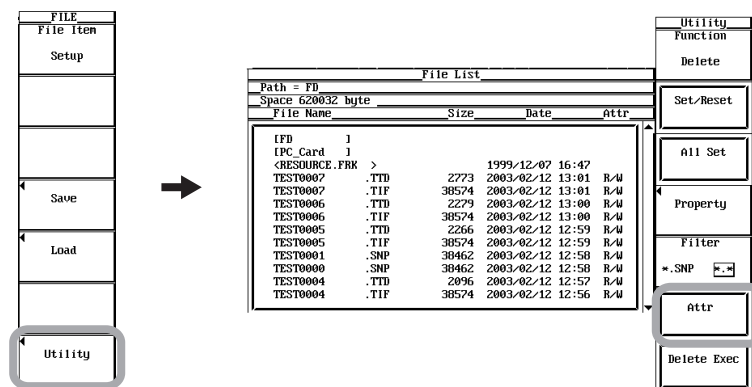

Deleting Files

6. Press the **Function** soft key. The Function menu appears.
7. Press the **Delete** soft key.

Selecting/Resetting the File to Be Deleted One at a Time

8. Turn **jog shuttle** to select a file.
9. Press the **Set/Reset** soft key. An asterisk (*) is displayed to the left of the selected file to indicate that it will be deleted. Pressing the **Set/Reset** soft key again removes the asterisk (*) to the left of the selected file. The file will not be deleted.

Proceed to step 11.

Selecting/Resetting the Files to Be Deleted at Once

8. Turn **jog shuttle** to select a file, directory, or medium.
9. Press the **All set** soft key. Asterisks (*) are displayed to the left of every file in the directory containing the selected file or directory to indicate that they will be deleted. At the same time, the All Set soft key changes to the All Reset soft key.
10. Press the **All Reset** soft key. Asterisks (*) are removed from the left of every file in the directory containing the selected file or directory to indicate that they will not be deleted. At the same time, the All Reset soft key changes to the All Set soft key.

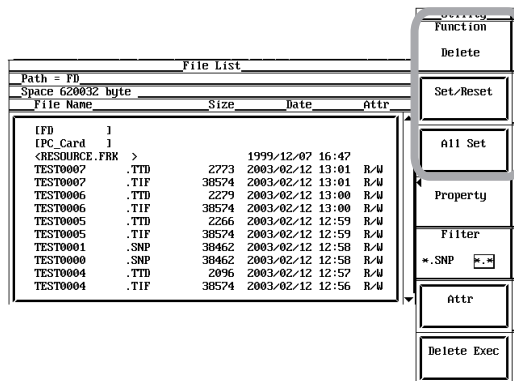

Executing the Delete Operation

11. Press the **Delete Exec** soft key. All files with asterisk marks are deleted.

Specifying the File to Be Displayed in the File List Window and Viewing File Properties

12. The procedure is the same as steps 22 to 25 on page 12-23.

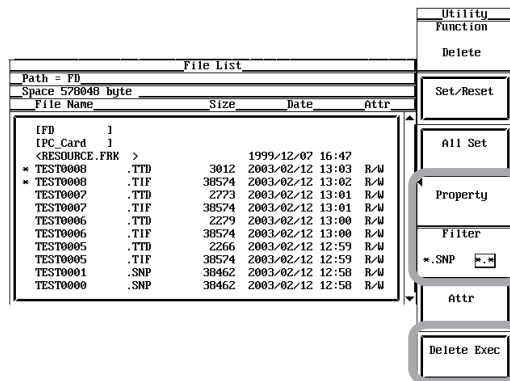

Explanation**Selecting the Storage Medium and Directory**

Storage media to and from which saving and loading are possible are displayed on the File List window.

Display Examples of Storage Media

FD	Floppy disk
ZIP	Zip disk
PC_Card	PC card
SCSI5	SCSI device with the ID number set to 5*
SCSI5-1	Partition 1 of a SCSI device whose ID number is 1*
NetWork	Network drive (when the Ethernet interface option is installed)
USB	USB storage

* When a SCSI device whose ID number is 5 is connected

Selecting the File Attribute (Excluding Net Drive)

Select the file attribute of each file from the following.

R/W

Read and write possible.

R

Read only. Cannot write to the file or delete the file.

Selecting the Files to Be Deleted

You can delete all files that have an asterisk to the left of the file name. There are two methods in selecting the files to be deleted.

Selecting the files one at a time

Press the Set/Reset soft key to place * marks to the left of the files one at a time.

Selecting the files at once

Places an asterisk to the left of all the file names selected collectively using the All Set soft key.

Selecting a file or directory and pressing the All Set soft key places an asterisk on every file in the directory containing the selected file or directory.

Specifying the File to Be Displayed on the File List Window

Specify the type of files to be displayed.

*.extension

Displays only the data file that was selected in the File Item setup menu and the data type menu.

.

Displays all the files in the directory.

12.14 Changing the File Attributes and Deleting Files

Properties

Displays the following information about the selected file: the name, extension, the file size, the date the file was saved, the attribute, the comment, etc.

Note

- Files cannot be deleted while the waveform acquisition is in progress.
 - Files that are deleted cannot be recovered. Be sure you erase the correct files.
 - You can not delete directories if there are files in them.
 - If an error occurs while deleting multiple files, the files after the error occurrence are not deleted.
 - You cannot change a directory attribute.
 - This function cannot be used when using the FTP server function, FTP client function, the LPR client function, or Web server function.
-

12.15 Copying Files

CAUTION

Do not remove the storage medium (disk) or turn OFF the power when the access indicator or icon of the storage medium is blinking. Doing so can damage the storage medium or destroy the data on the medium.

Procedure

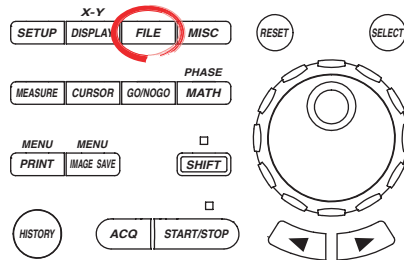

- To exit the menu during operation, press **ESC** located above the soft keys.
- In the procedural explanation below, the term *jog shuttle* & **SELECT** refers to the operation of selecting/setting items and entering values using the **jog shuttle** and **SELECT** and **RESET** keys. For details on this operation, see sections 4.1 or 4.2.
- For a description of the operation using a USB keyboard or a USB mouse, see section 4.3.

1. Press **FILE**. The FILE menu appears.
2. Press the **Utility** soft key. The Utility menu and the File List window appear.
3. Press the **Function** soft key. The Function menu appears.
4. Press the **Copy** soft key.

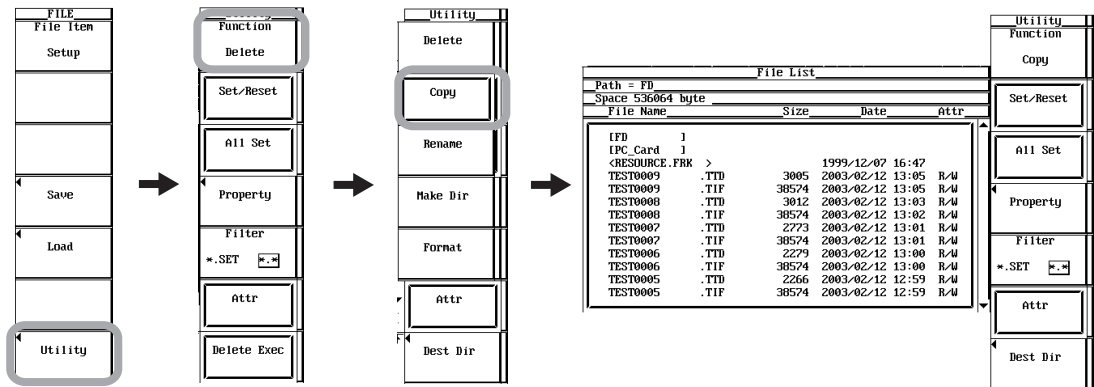

Selecting the Copy Source

Selecting the Copy Source Storage Medium or Directory

5. The procedure is the same as steps 14 and 15 on page 12-22.

Selecting/Resetting the Copy Source Files One at a Time

6. Turn **jog shuttle** to select a file.
7. Press the **Set/Reset** soft key. An asterisk (*) is displayed to the left of the selected file to indicate that it will be copied. Pressing the Set/Reset soft key again removes the asterisk (*) to the left of the selected file. The file will not be copied. Proceed to step 11.

Selecting/Resetting the Copy Source Files at Once

8. Turn **jog shuttle** to select a file, directory, or medium.
9. Press the **All set** soft key. Asterisks (*) are displayed to the left of every file in the directory containing the selected file or directory to indicate that they will be copied. At the same time, the All Set soft key changes to the All Reset soft key.
10. Press the **All Reset** soft key. Asterisks (*) are removed from the left of every file in the directory containing the selected file or directory to indicate that they will not be copied. At the same time, the All Reset soft key changes to the All Set soft key.

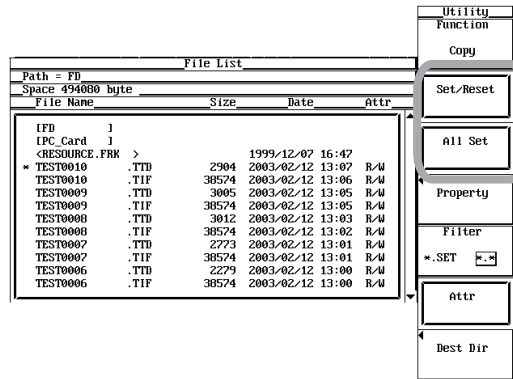

Selecting the Copy Destination

11. Press the **Dest Dir** soft key. The Copy menu and the copy destination File List window appears.

Selecting the Copy Destination Storage Medium or Directory

12. The procedure is the same as steps 13 to 15 on page 12-22.

Executing the Copy Operation

13. Press the **Copy Exec** soft key. All the copy source files with asterisk marks are copied.

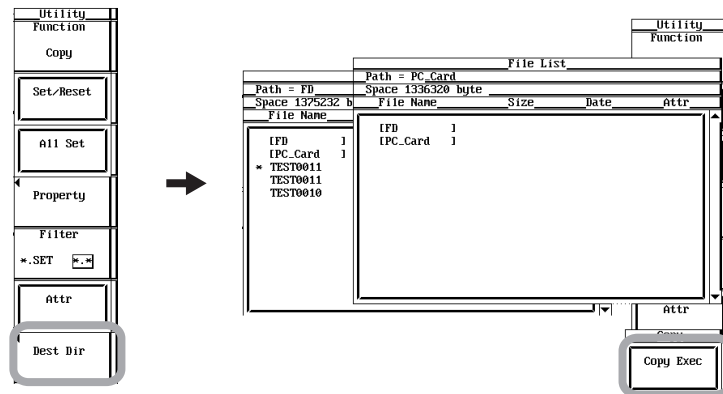

Specifying the File to Be Displayed in the File List Window and Viewing File Properties

14. The procedure is the same as steps 22 to 25 on page 12-23.

Explanation**Selecting the Copy Source Files**

You can copy all files that have an asterisk to the left of the file name. There are two ways to select the files to be copied.

Selecting the files one at a time

Press the Set/Reset soft key to place * marks to the left of the files one at a time.

Selecting all files at once

Places an asterisk to the left of all the file names using the All Set soft key.

If you select a file and press the All Set soft key, asterisk marks are placed on all the files in the current directory.

Specifying the File to Be Displayed on the File List Window

Specify the type of files to be displayed.

*.extension

Displays only the data file that was selected in the File Item setup menu and the data type menu.

.

Displays all the files in the directory.

Properties

Displays the following information about the selected file: the name, extension, the file size, the date the file was saved, the attribute, the comment, etc.

Reduce Image Display on the File List

When you select a screen image data file on the File List, the reduced image of the screen image is displayed at the upper right section of the File List. Reduced images are displayed only for screen image data. Reduced images for waveform data and setup data are not displayed. In addition, reduce images do not display the file name and color information.

Note

-
- Files cannot be copied while waveform acquisition is in progress.
 - If an error occurs while copying multiple files, the files after the error occurrence are not copied.
 - You cannot change a directory attribute.
 - You cannot copy files if files with the same file name exist at the copy destination.
 - You cannot copy the same files to another directory after copying the files. Select the files to be copied again and copy them.
 - This function cannot be used when using the FTP server function, FTP client function, the LPR client function, or the Web server function.
-

12.16 Changing the Directory or File Name of the Storage Medium and Creating Directories

CAUTION

Do not remove the storage medium (disk) or turn OFF the power when the access indicator or icon of the storage medium is blinking. Doing so can damage the storage medium or destroy the data on the medium.

Procedure

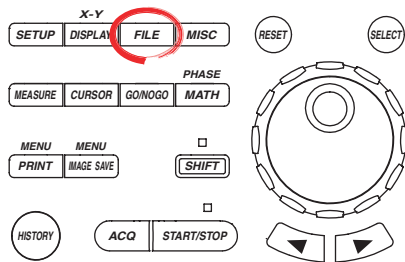

- To exit the menu during operation, press **ESC** located above the soft keys.
- In the procedural explanation below, the term *jog shuttle* & **SELECT** refers to the operation of selecting/setting items and entering values using the *jog shuttle* and **SELECT** and **RESET** keys. For details on this operation, see sections 4.1 or 4.2.
- For a description of the operation using a USB keyboard or a USB mouse, see section 4.3.

- Press **FILE**. The FILE menu appears.
- Press the **Utility** soft key to display the Utility menu and the File List window.
- Press the **Function** soft key. The Function menu appears.

Renaming a Directory or File

- Press the **Rename** soft key.

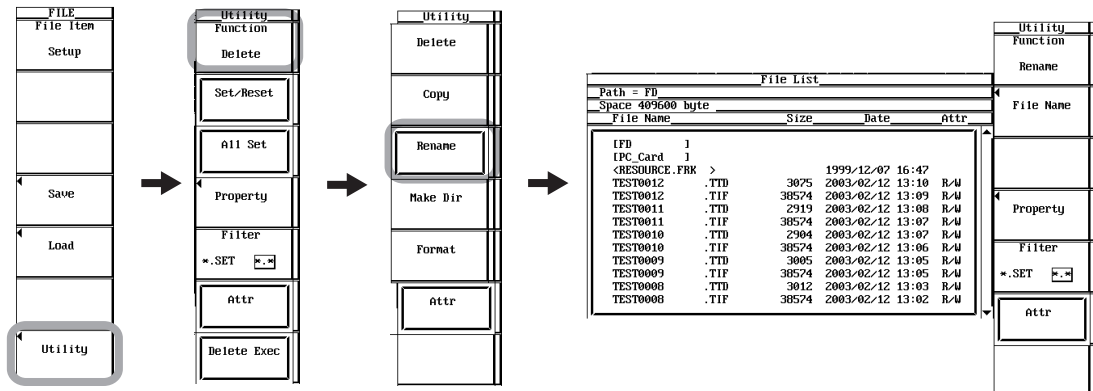

Selecting the Storage Medium/Directory

- The procedure is the same as steps 14 to 15 on page 12-22.

Changing the File Attribute

- The procedure is the same as steps 4 and 5 on page 12-43.

Renaming a Directory or File (Excluding Net Drive)

- Turn **jog shuttle** to select a directory name or file name.
- Press the **File Name** soft key to display the keyboard. The name of the selected directory or file is displayed in the entry box of the keyboard.
- Record the directory and file name.

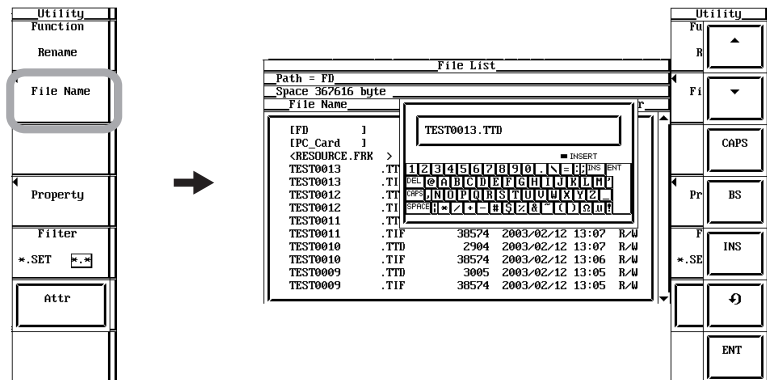

Specifying the File to Be Displayed in the File List Window and Viewing File Properties

- The procedure is the same as steps 22 to 25 on page 12-23.

Creating a Directory

- Display the Function menu according to steps 1 to 3 on page 12-50.
- Press the **Make Dir** soft key.

Selecting the Storage Medium/Directory

- The procedure is the same as steps 14 and 15 on page 12-22.

Creating a Directory

- Press the **Dir Name** soft key. A keyboard appears.
- Enter the directory name.

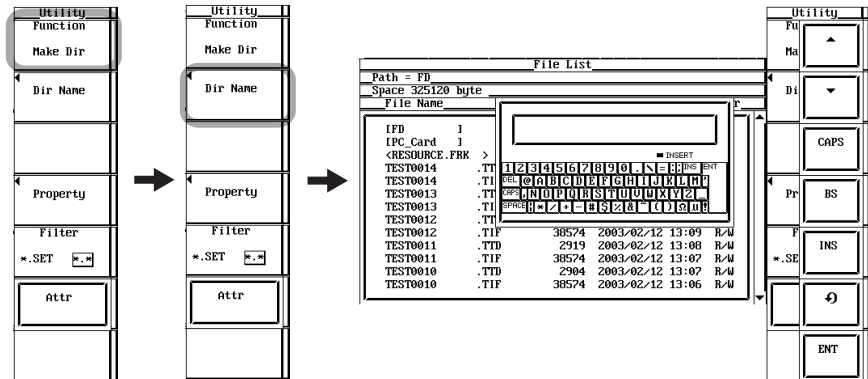

Specifying the File to Be Displayed in the File List Window and Viewing File Properties

- The procedure is the same as steps 22 to 25 on page 12-23.

Explanation

Storage Medium and Directory

Storage media which saving and loading are possible are displayed on the File List window.

Display Examples of Storage Media

FD	Floppy disk
ZIP	Zip disk
PC_Card	PC card
SCSI5	SCSI device with the ID number set to 5*
SCSI5-1	Partition 1 of a SCSI device whose ID number is 5*
NetWork	Network drive (when the Ethernet interface option is installed)
USB	USB storage

* When a SCSI device whose ID number is 5 is connected

Selecting the File Attribute

You can select file attributes for each file.

R/W	Read and write possible.
R	Read only. Cannot write to the file or delete the file.

Renaming a Directory or File**Number and types of characters that can be used**

Item	Number of Characters	Characters That Can Be Used*
File name	1 to 14 characters	0 to 9, A to Z, %, _, (,), -

* However, a directory name that starts with "ND" (ND000 for example) is not allowed.

Creating a Directory

You can create a new directory on the storage medium. See above for the assignment of the directory name when creating a new directory.

Specifying the File to Be Displayed on the File List Window

Specify the type of files to be displayed.

*.extension	Displays only the data file that was selected in the File Item setup menu and the data type menu.
.	Displays all the files in the directory.

Properties

Displays the following information about the selected file: the name, extension, the file size, the date the file was saved, the attribute, the comment, etc.

Reduce Image Display on the File List

When you select a screen image data file on the File List, the reduced image of the screen image is displayed at the upper right section of the File List. Reduced images are displayed only for screen image data. Reduced images for waveform data and setup data are not displayed. In addition, reduce images do not display the file name and color information.

Note

- You cannot rename a directory/file or create a new directory while the waveform acquisition is in progress (START/STOP indicator is ON).
- You cannot change a directory attribute.
- If a file with the same name already exists in the same directory, the file cannot be renamed.
- If a directory with the same name already exists in the same directory, the directory cannot be created.
- This function cannot be used when using the FTP server function, FTP client function, the LPR client function, or the Web server function.
- Files that do not have an archive attribute are not displayed in the File List window. Do not remove the archive attribute of the files saved by the DL7400 using your PC.

13.1 Connecting the DL7400 to the Network

Ethernet Interface Specifications

A 100BASE-TX port is provided on the rear panel of the DL7400.

Item	Specifications
Number of communication ports	1
Electrical and mechanical specifications	Conforms to IEEE802.3
Transmission system	Ethernet (100BASE-TX/10BASE-T)
Transmission rate	100 Mbps max.
Communication protocol	TCP/IP
Supported service	FTP server, FTP client (network drive), LPR client (network printer), SMTP client (mail transmission), Web server, DHCP, DNS, SNTP, and Web DAV*
Connector type	RJ-45 connector

* SNTP and Web DAV are available only on models with a firmware version of 1.30 or later.

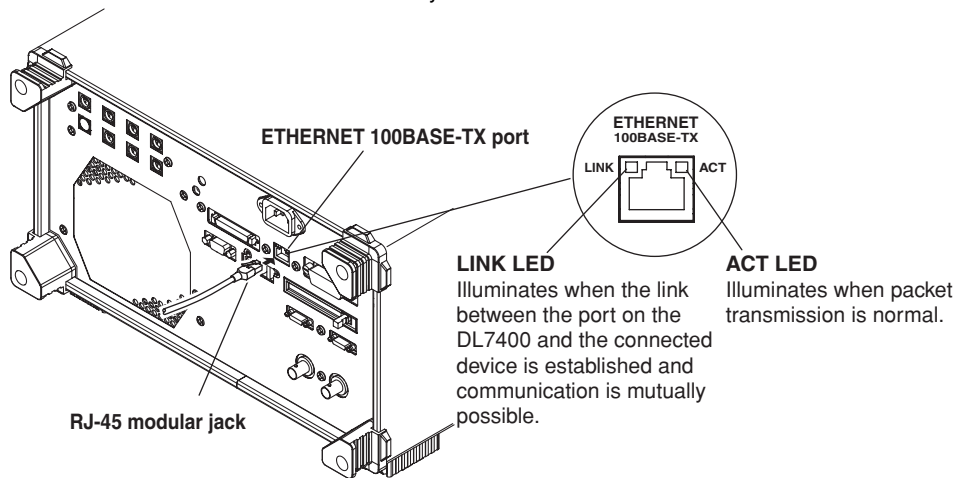

Items Necessary for Connection

Cable

Be sure to use one the following cables for connection.

- UTP (Unshielded Twisted-Pair) cable (category 5 or better)
- STP (Shielded Twisted-Pair) cable (category 5 or better)

13.1 Connecting the DL7400 to the Network

Connection Procedure

When Connecting to a Network PC or Workstation

1. Turn OFF the DL7400.
2. Connect one end of the UTP (or STP) cable to the ETHERNET 100BASE-TX terminal on the rear panel.
3. Connect the other end of the UTP (or STP) cable to a hub or router.
4. Turn ON the DL7400.

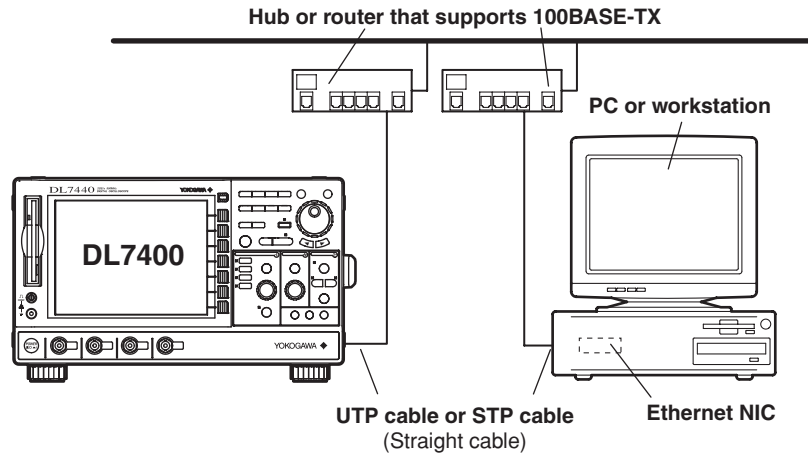

When Making a One-to-One Connection to the PC or Workstation

1. Turn OFF the DL7400 and the PC or workstation.
2. Connect one end of the UTP (or STP) cable to the ETHERNET 100BASE-TX terminal on the rear panel.
3. Connect the other end of the UTP (or STP) cable to a hub or router.
4. Likewise, connect the PC or workstation to a hub or router.
5. Turn ON the DL7400.

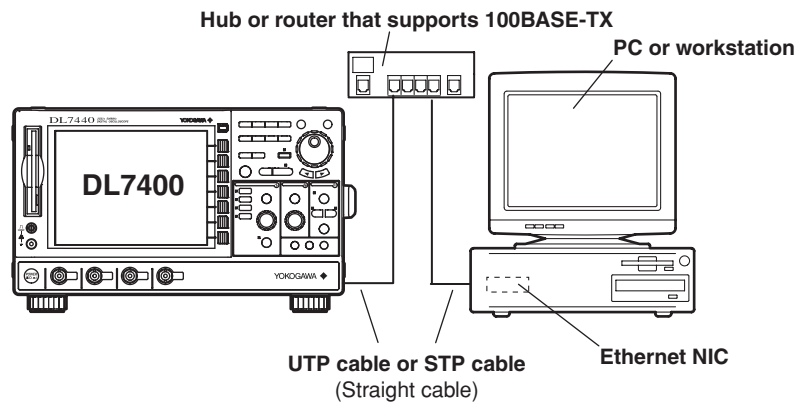

Note

- When connecting the PC or workstation one-to-one, a NIC (a 10BASE-T/100BASE-TX autoswitching card) is required for the PC or workstation.
- When using a UTP cable or STP cable (straight cable), be sure to use a category 5 or better cable.
- Avoid connecting the PC or workstation directly to the DL7400 without going through the hub or router. Operations are not guaranteed for communications using direct connection.

13.2 Setting Up TCP/IP

Procedure

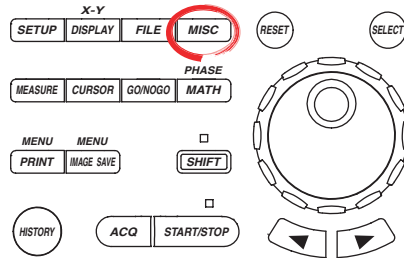

- To exit the menu during operation, press **ESC** located above the soft keys.
- In the procedural explanation below, the term *jog shuttle & SELECT* refers to the operation of selecting/setting items and entering values using the **jog shuttle** and **SELECT** and **RESET** keys. For details on this operation, see sections 4.1 or 4.2.
- For a description of the operation using a USB keyboard or a USB mouse, see section 4.3.

Entering the TCP/IP Setup Menu

1. Press **MISC**. The MISC menu appears.
2. Press the **Network** soft key. The Network menu appears.
3. Press the **TCP/IP Setup** soft key. The TCP/IP Setup dialog box opens.

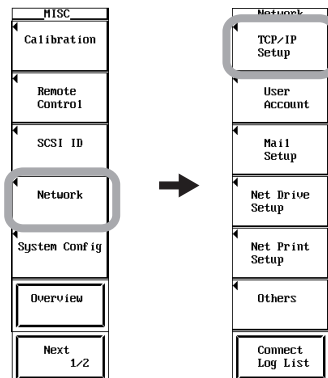

Turning ON/OFF DHCP

4. Use **jog shuttle & SELECT** to set DHCP to ON or OFF.
 - If you select OFF, proceed to step 5.
 - If you set DHCP to ON, you do not have to set the IP address, subnet mask, default gateway below. To set up the DNS, proceed to step 8. If you do not wish to set up the DNS, check the network cable connection and restart the DL7400. The IP address, subnet mask, and default gateway are automatically configured.

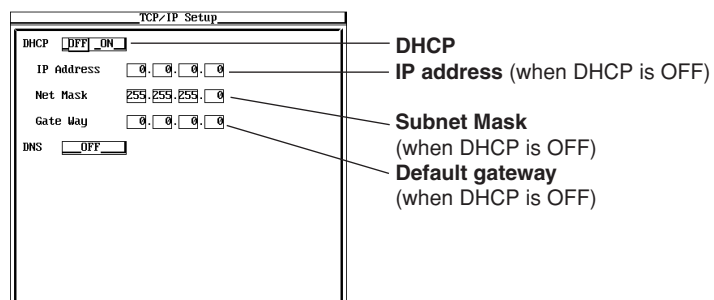

13.2 Setting Up the TCP/IP

Setting the IP Address

If DHCP was set to OFF in step 4, set the IP address.

5. Use **jog shuttle & SELECT** to set the IP Address. Enter using values in the range of 0 to 255.

Setting the Subnet Mask

If DHCP was set to OFF in step 4, set the subnet mask.

6. Use **jog shuttle & SELECT** to set the Net Mask. Enter using values in the range of 0 to 255.

Setting the Default Gateway

If DHCP was set to OFF in step 4, set the default gateway.

7. Use **jog shuttle & SELECT** to set the Gate Way. Enter using values in the range of 0 to 255.

Setting DNS

8. Use **jog shuttle & SELECT** to set DNS to ON, OFF, or AUTO*.

* AUTO can be selected only when DHCP is ON.

- When DNS is set to AUTO, the domain name and DNS server name are automatically configured by power-cycling the DL7400.
- If DNS is set to ON, set the domain name, DNS server name, and domain suffix.
- If DNS is set to OFF, check the network cable connection and power-cycle the DL7400.

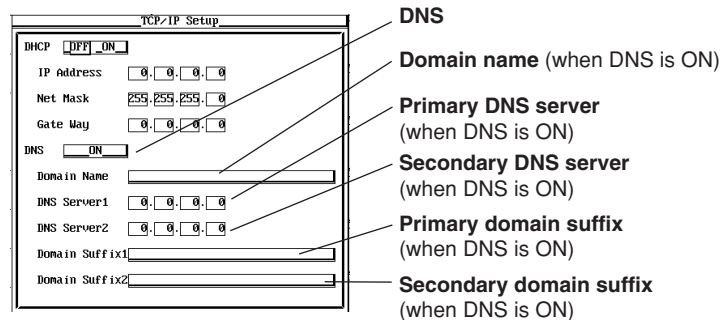

Setting the Domain Name

If DNS was set to ON in step 8, set the domain name.

9. Use **jog shuttle & SELECT** to enter the domain name.

Setting the DNS Server Address

If DNS was set to ON in step 8, set the DNS server address.

10. Use **jog shuttle & SELECT** to set DNS Server1 (primary DNS server). Enter using values in the range of 0 to 255.
11. Likewise, set the secondary DNS server in DNS Server2.

Setting the Domain Suffix

If DNS was set to ON in step 8, set the domain suffix.

12. Use **jog shuttle & SELECT** to enter Domain Suffix1 (primary domain suffix).
13. Likewise, set the secondary domain suffix in Domain Suffix2.

Turning ON/OFF the Power

14. To apply the new settings, the DL7400 must be power cycled. After all the settings are complete, turn the power to the DL7400 OFF, then back ON again.

Explanation

The following TCP/IP settings must be entered to use the Ethernet communications functions on the DL7400.

IP address
Subnet mask
Default gateway

IP Address (Internet Protocol Address)

You can assign an IP address to the DL7400. The default setting is 0.0.0.0.

The IP address is an ID that is assigned to each device on an IP network such as the internet or an intranet. The address is a 32-bit value expressed using four octets (each 0 to 255), each separated by a period as in 192.168.111.24. Obtain an IP address from your network administrator. The setting is automatically configured in environments using DHCP.

Subnet Mask

You can set the mask value used when determining the subnet network address from the IP address. The default setting is 255.255.255.0. Huge TCP/IP networks such as the Internet are often divided up into smaller networks called sub networks. The subnet mask is a 32 bit value that specifies the number of bits of the IP address used to identify the network address. The portion other than the network address is the host address that identifies individual computers on the network.

Consult your network administrator for the subnet mask value. You may not need to set the value. The setting is automatically configured in environments using DHCP.

Default Gateway

You can set the IP address of the gateway (default gateway) used to communicate with other networks. The default setting is 0.0.0.0. The default gateway has control functions that handle protocol exchanges when communicating with multiple networks, so that data transmission is carried out smoothly.

Consult your network administrator for the default gateway value. You may not need to set the value. The setting is automatically configured in environments using DHCP.

DHCP (Dynamic Host Configuration Protocol)

DCHP is a protocol that allocates setup information that is needed temporarily to PCs connecting to the network. When DHCP is turned ON, the following settings are automatically assigned.

IP address
Subnet mask
Default gateway
DNS

To use DHCP, the network must have a DHCP server. Consult your network administrator to see if DHCP can be used. When DHCP is turned ON, different settings may be assigned each time the power is turned ON. When using the FTP server function (see section 13.6), be sure to check the IP address and other settings of the DL7400 using a PC or workstation each time you turn ON the DL7400.

DNS (Domain Name System)

DNS is a system used to associate names used on the Internet called *host names* and *domain names* with IP addresses. Given AAA.BBBBB.com, AAA is the host name and BBBBB.com is the domain name. Instead of using the IP address, which is a sequence of numbers, the host name and domain name can be used to access the network. On the DL7400, you can specify the host by name instead of by IP address when using the FTP client function (see section 13.3) or the LPR client function (see sections 13.4). You set the domain name, the DNS server address (0.0.0.0 by default), and the domain suffix. In networks that support DHCP, these settings can be configured automatically. For details, consult your network administrator.

DNS Server

Up to two DNS server addresses can be specified (primary and secondary). If the primary DNS server is down, the secondary DNS server is automatically looked up for the mapping of the host name/domain name and IP address.

Domain Suffix

When the IP address corresponding to the server name with the aforementioned domain name is not found, the system may be set up to search using a different domain name. Enter this alternate domain name as the domain suffix. Up to two domain suffixes can be specified, Domain Suffix1 (primary), and Domain Suffix2 (secondary).

Note

- If you changed settings related to the Ethernet network, the DL7400 must be power cycled.
- If the DL7400 is turned ON with the DHCP function enabled without an Ethernet cable connected, communications and file functions may not operate properly. In this case, turn DHCP OFF and power cycle the DL7400.

Configuring the TCP/IP Settings of the PC

Communication parameters such as the IP address must be specified also on the PC side. Communication parameters are specified for each Ethernet NIC that is installed in the PC. Here, the settings of the NIC for connecting your PC and the DL7400 are explained.

If the IP address and other parameters are to be obtained dynamically using the DHCP server, the following settings are not necessary. In this case, select **Obtain an IP address automatically** under the **IP Address** tab of the **TCP/IP Properties** dialog box.

For example, if you are connecting a PC and the DL7400 to an independent Ethernet network, you can specify parameters as indicated in the next table. For details on the parameters, consult your system or network administrator.

Parameter	Value	Remarks
IP address	Example: 192.168.21.128	IP address for the PC
Subnet mask	Example: 255.255.255.0	Set the same value as the subnet mask that was specified for the DL7400.
Gateway	None	
DNS	Disable	
WINS	Disable	

The following procedure describes the steps for Windows 95/98/ME. For Windows NT/2000 Pro/XP, carry out equivalent steps accordingly.

1. Choose **Settings > Control Panel** from the **Start** menu to open the Control Panel folder.
2. Double-click the **Network** icon to display the following network setup dialog box.
3. Select the **TCP/IP** corresponding to the Ethernet NIC that is connected to the PC and click **Properties** to display the TCP/IP properties setup dialog box.

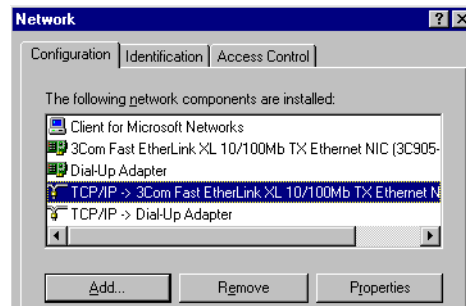

4. Set the parameters such as the IP address according to the table above and click **OK**.

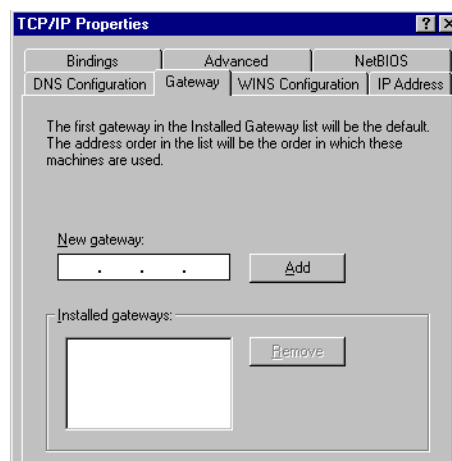
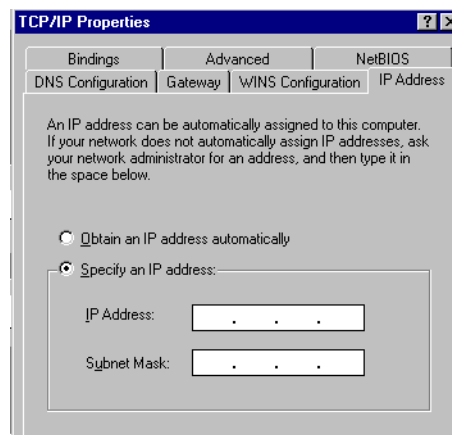

13.3 Saving and Loading Waveform/Setup/Image Data on a Network Drive (FTP Client Function)

Procedure

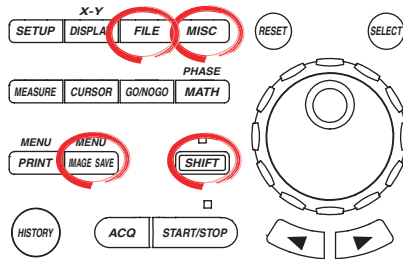

- To exit the menu during operation, press **ESC** located above the soft keys.
- In the procedural explanation below, the term *jog shuttle & SELECT* refers to the operation of selecting/setting items and entering values using the **jog shuttle** and **SELECT** and **RESET** keys. For details on this operation, see sections 4.1 or 4.2.
- For a description of the operation using a USB keyboard or a USB mouse, see section 4.3.

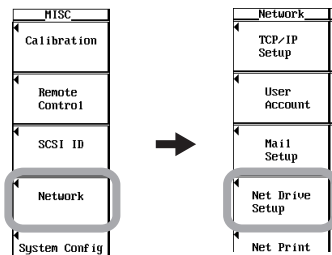

Setting the Network Drive

1. Press **MISC**. The MISC menu appears.
2. Press the **Network** soft key. The Network menu appears.
3. Press the **Net Drive Setup** soft key. The Net Drive Setup dialog box opens.



4. Use **jog shuttle & SELECT** to enter the FTP Server (IP address). If you are using DNS, you can specify the server by name.
5. Use **jog shuttle & SELECT** to enter the Login Name using up to 15 characters.
6. Use **jog shuttle & SELECT** to enter the Password (corresponding to the Login Name) using up to 15 characters.
If Login Name is set to anonymous in step 5, you do not have to enter the password.
7. Use **jog shuttle & SELECT** to set Time Out. The selectable range is 1 to 3600 (s).

Connecting to or Disconnecting from the Network Drive

8. Turn the **jog shuttle** to move the cursor to **Connect** and press **SELECT** to establish a connection. When the connection is established,  is displayed at the upper right corner of the screen. Use the **jog shuttle** to move the cursor to **Disconnect**, then press **SELECT** to close the connection. The  displayed at the upper right corner of the screen disappears.

13.3 Saving and Loading Waveform/Setup/Image Data on a Network Drive (FTP Client Function)

Saving/Loading the Waveform Data or Setup Data

9. Press **FILE**. The FILE menu appears.
10. Press the **Utility** soft key. The File List window appears.
11. Use **jog shuttle & SELECT** to select NetWork.

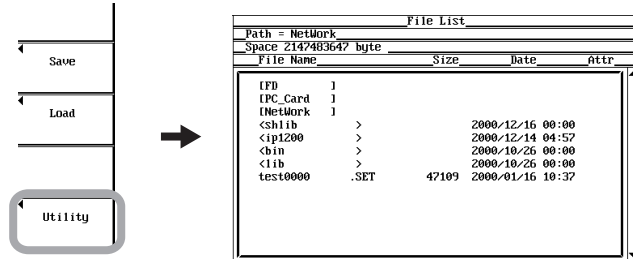

12. Perform the save or load operation according to the procedures given in sections 12.7 to 12.11.

Saving Screen Images

9. Press **SHIFT+IMAGE SAVE (MENU)**. The IMAGE menu appears.
10. Press the **File List** soft key. The File List window appears.
11. Use **jog shuttle & SELECT** to select NetWork.

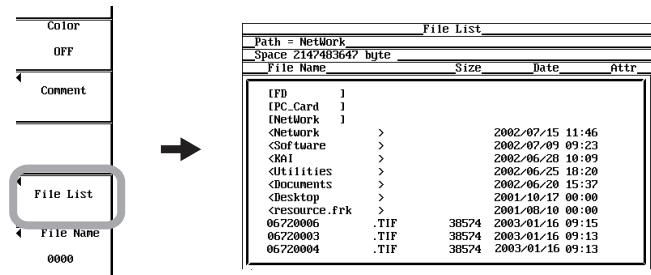

12. Perform the save operation according to the procedures given in section 12.12.

13.3 Saving and Loading Waveform/Setup/Image Data on a Network Drive (FTP Client Function)

Note

- An FTP server software must be running on the PC or workstation to which the DL7400 is to be connected. In addition, the following points need attention regarding the server program settings.
 - Set the list output (string returned by the dir command) to UNIX format.
 - Set the home directory and its subdirectories to allow writing.
 - The client cannot move above the home directory.
 - The newest file is not necessarily displayed at the top of the file list.
 - The length of file names and directory names that can be accessed varies depending on the server software.
 - Depending on the server, the symbol "<..>" that indicates a higher directory may not be displayed.
 - The time information in the file list will not be displayed correctly for the following cases.
 - On Windows NT when the time stamp is displayed using am and pm.
 - Servers that return characters other than ASCII characters in the list.
 - The following operations are not possible.
 - Turning file protect ON and OFF on saved files.
 - Formatting a network drive.
 - Copying between network drives.
 - Renaming a file on the network.
 - This function cannot be used when using the FTP server function or the Web server function.
 - To use this function, you must configure TCP/IP according to the procedure given in section 13.2.
 - To apply new settings that are made while connected to a network drive, drop the connection using Disconnect and reconnect.
 - If you are disconnected by the server when using the FTP client, you will be automatically reconnected if you perform a file operation. This also holds true if the network drive is selected for Save to File when using an action trigger or GO/NO-GO.
 - When loading waveform data from a network drive, the loading may take time depending on the network conditions. If there is enough free space on the storage medium, you can reduce the time by copying the waveform data from the network drive to the storage medium and loading the data from the storage medium.
-

Explanation

As with the floppy disk drive and Zip disk drive, you can save or load waveform data or setup data or save screen image data to a network drive via the Ethernet network.

Network Drive

FTP Server

You can enter the IP address of the FTP server (the PC or workstation running the FTP server) on the network to which waveform and setup data will be saved. On networks supporting DNS, you can specify the host and domain by name instead of the IP address.

Login Name

You can enter the login name using up to 15 characters. The default setting is "anonymous." The characters that can be used are all the ASCII characters on the keyboard.

Password

You can enter the password corresponding to the login name using up to 15 characters. The characters that can be used are all the ASCII characters on the keyboard.

Time Out

When an FTP server is accessed from the DL7400 and data is not transmitted for a certain period of time (timeout time), the DL7400 decides that the transmission to the FTP server is not possible and closes the connection. You can set the timeout value in the range of 1 to 3600 s. The default setting is 15 s.

13.4 Entering Settings for Printing Screen Images on the Network Printer (LPR Client Function)

Procedure

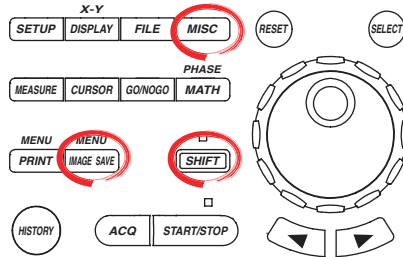

- To exit the menu during operation, press **ESC** located above the soft keys.
- In the procedural explanation below, the term *jog shuttle & SELECT* refers to the operation of selecting/setting items and entering values using the **jog shuttle** and **SELECT** and **RESET** keys. For details on this operation, see sections 4.1 or 4.2.
- For a description of the operation using a USB keyboard or a USB mouse, see section 4.3.

Setting the Network Printer

1. Press **MISC**. The MISC menu appears.
2. Press the **Network** soft key. The Network menu appears.
3. Press the **Net Print Setup** soft key. The Net Print Setup dialog box opens.

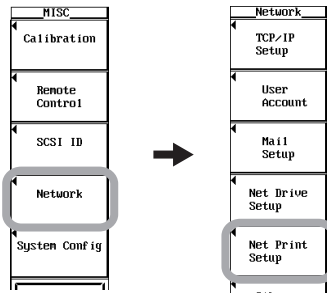

3. Use **jog shuttle & SELECT** to enter the LPR Server (IP address of the printer server). If you are using DNS, you can specify the server by name.
4. Use **jog shuttle & SELECT** to enter the LPR Name (printer name).

Net Print Setup	
LPR Server	11.0.0.0
LPR Name	PNSSTRU

Printing Screen Images

5. Print screen images according to the procedures given in section 11.4.

Note

- To use this function, you must configure TCP/IP according to the procedure given in section 13.2.
- Printing is possible on printers that support the TCP/IP protocol.
- This function cannot be used when using the FTP server function or Web server function or when performing file operations.

Explanation

As with the built-in printer (optional), you can print the screen image on a network printer via the Ethernet network.

Network Printer

LPR Server

You can specify the IP address of the network printer server. On networks supporting DNS, you can specify the host and domain by name instead of the IP address.

Printer Name (LPR Name)

You can specify the name of the printer on which screen images will be printed.

13.5 Sending Periodic or Action Mail (SMTP Client Function)

Procedure

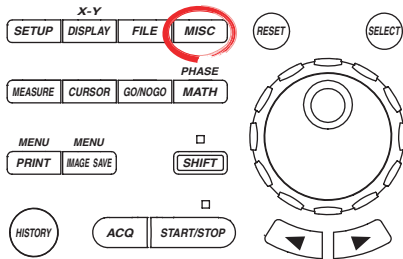

- To exit the menu during operation, press **ESC** located above the soft keys.
- In the procedural explanation below, the term *jog shuttle & SELECT* refers to the operation of selecting/setting items and entering values using the **jog shuttle** and **SELECT** and **RESET** keys. For details on this operation, see sections 4.1 or 4.2.
- For a description of the operation using a USB keyboard or a USB mouse, see section 4.3.

Setting the Mail

1. Press **MISC**. The MISC menu appears.
2. Press the **Network** soft key. The Network menu appears.
3. Press the **Mail Setup** soft key. The Mail Setup dialog box opens.

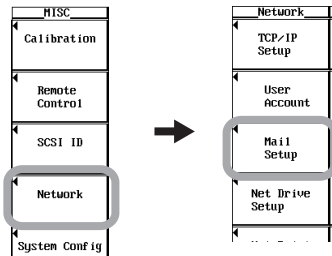

4. Use **jog shuttle & SELECT** to enter the Mail Server (IP address of the mail server). If you are using DNS, you can specify the server by name.
5. Use **jog shuttle & SELECT** to enter the Mail Address (recipient mail address) using up to 40 characters.
6. As necessary, use **jog shuttle & SELECT** to enter a comment using up to 30 characters.
7. As necessary, turn the jog shuttle to set Attached Image File to ON (attach the image data) or OFF (not attach the image data).

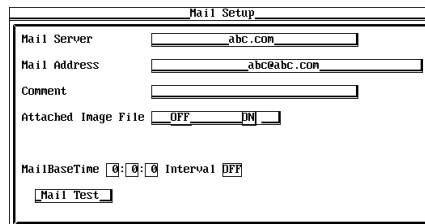

Setting the Transmission Time of Period Mail (For action mail, see “Setting Conditions for Sending Mail (Action Mail)” on the next page.)

8. Use **jog shuttle & SELECT** to enter the MailBaseTime (time when mail is to be sent).
9. Use **jog shuttle & SELECT** to set the Interval (interval for sending mail) in the range of 1h to 24h. If you are only using action mail, set this to OFF.

Sending a Test Mail

10. Turn the **jog shuttle** to move the cursor to **Mail Test** and press **SELECT** to send a test mail to the specified recipient.

Setting the Conditions for Sending Mail (Action Mail)

Perform steps 1 to 6 on the previous page.

A mail is sent when the following conditions are met.

- When a trigger is activated
For the setup procedure, see section 6.16.
- By GO/NOGO determination
For the setup procedure, see sections 10.9 and 10.10.

Note

- The sender (From) address of the mail messages sent by the DL7400 is the same as the specified recipient address.
- If the transmitted contents indicate error logs, the most recent error is at the top of the error log.
- To use this function, you must configure TCP/IP according to the procedure given in section 13.2.
- If you set Interval to OFF, periodic mail is not sent.

Explanation**Periodic Mail**

The DL7400 status can be sent periodically to a specified mail address on the network.

Action Mail

Information such as the trigger time can be sent to a specified mail address on the network as an action of GO/NO-GO determination or action-on-trigger.

Mail**Mail Server**

You can specify the IP address of the network mail server. On networks supporting DNS, you can specify the host and domain by name instead of the IP address.

Mail Address

You can set the address of the mail recipient on the network using up to 40 characters.

Comment

The comment is written on the first line of the transmitted mail. Enter it as necessary. You can enter a comment using up to 30 characters.

Attaching Screen Image Data (Attached Image File, Firmware Version 1.30 or Later)

The screen image shown at the time of mail transmission can be attached to the mail. The data format is fixed to PNG format. Color is ON (256 colors). For details on the data format, see section 12.12, "Saving Screen Image Data."

The file name is DL_image.png. The file name used when attaching screen image data as an action of GO/NO-GO determination or action-on-trigger is DL_nnnn.png (where nnnn is an automatically assigned number in the range of 0001 to 1000).

Transmission Time (MailBaseTime for Periodic Mail Only)

The time when mail transmission is to start can be set in units of hours, minutes, and seconds.

Selectable range	0:0:0 to 23:59:59
------------------	-------------------

13.5 Sending Periodic or Action Mail (SMTP Client Function)

Transmission Interval (Interval for Periodic Mail Only)

You can select the mail transmission interval.

OFF, 1H, 2H, 3H, 4H, 6H, 8H, 12H, or 24H

- If you select OFF, periodic mails cannot be transmitted.
- If you are only using the action mail function, set this to OFF.

Sending a Test Mail

A test mail is sent to the address specified by Mail Address.

DL7400 Information That Is Transmitted

The following information is transmitted.

Periodic Mail

- **Acquisition condition**
Start/Stop, trigger condition, and acquisition counter
- **Error log information**
Error number and corrective action in English (up to 16 errors)
- **Success/Fail information of GO/NO-GO**
Only when GO/NO-GO determination is executed (see section 10.9 or 10.10)
- **Results of waveform parameter measurement**
Results of automated measurement of waveform parameters (see section 10.6 or 10.8) or results of automated measurement parameters of when GO/NO-GO determination is executed using waveform parameters (see section 10.10).

Action Mail

- **Acquisition condition**
Start/Stop, acquisition counter
- **Trigger time**
- **Success/Fail information of GO/NO-GO**
Only when GO/NO-GO determination is executed (see section 10.9 or 10.10)
- **Fail cause**
Only when GO/NO-GO determination is executed (see section 10.9 or 10.10)
- **Results of waveform parameter measurement**
Results of automated measurement of waveform parameters (see section 10.6 or 10.8) or results of automated measurement parameters of when GO/NO-GO determination is executed using waveform parameters (see section 10.10).

Example of Transmitted Content**Periodic Mail**

```
[Comment]      aaaaaa

[ACQ Status]    Stopped      162

[GO/NOGO Status]  Success: 140    Fail: 21

Max (C1)       4.16667V
SDv (C2)       697.941mV
Freq(C3)       500.0000kHz
+Wd (C4)       1.00 us>

ErrNo 004 Completed GO/NO-GO.
ErrNo 806 GO/NO-GO is in execution. Please press the Abort
key.

ErrNo 004 Completed GO/NO-GO.
ErrNo 806 GO/NO-GO is in execution. Please press the Abort
key.
Stop.
```

Action Mail

```
[Comment]      aaaaaa

[ACQ Status]    Stopped      1

[Trigger Date and Time]  2003/02/17    17:28:59.38

[GO/NOGO Status]  Success: 9    Fail: 1

[NOGO Factor]    Param4(Ch4,tWd )

Max (C1)       4.16667V
SDv (C2)       697.941mV
Freq(C3)       500.0000kHz
+Wd (C4)       1.00us>
```

13.6 Accessing the DL7400 from a PC or Workstation (FTP Server Function)

Procedure

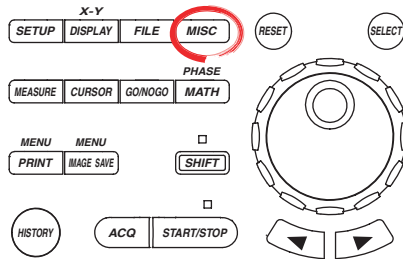

- To exit the menu during operation, press **ESC** located above the soft keys.
- In the procedural explanation below, the term *jog shuttle & SELECT* refers to the operation of selecting/setting items and entering values using the **jog shuttle** and **SELECT** and **RESET** keys. For details on this operation, see sections 4.1 or 4.2.
- For a description of the operation using a USB keyboard or a USB mouse, see section 4.3.

Creating User Accounts

1. Press **MISC**. The MISC menu appears.
2. Press the **Network** soft key. The Network menu appears.
3. Press the **User Account** soft key. The User Account dialog box opens.

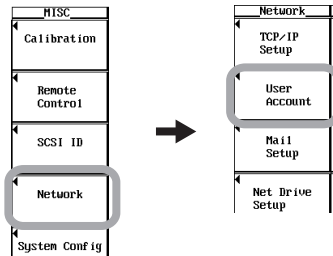

4. Use **jog shuttle & SELECT** to enter the User Name. Specify anonymous if you wish to allow access to all users. To restrict access, enter the user name using up to 15 characters.
5. Use **jog shuttle & SELECT** to enter the Password using up to 15 characters. Enter the password again for confirmation. If the user name is set to anonymous, you do not have to enter the password.
6. Use **jog shuttle & SELECT** to enter the Time Out. The connection to the network is automatically closed if there is no access to the DL7400 for the specified time.

User Account	
User Name	<input type="text" value="anonymous"/>
Password	<input type="text"/>
Time Out(sec)	<input type="text" value="5"/>

Executing the FTP Client Software

7. Execute an FTP client on the PC or workstation. Perform file operations using the user name specified in step 4.

Displaying the Log List

8. Press the **Connect Log List** soft key. The data and time, user name, and IP address of the 24 recent accesses are displayed.

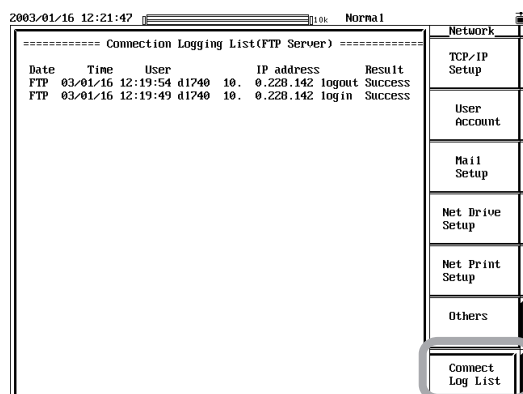

Note

- The DL7400 supports two clients, but file operations cannot be performed simultaneously.
- When the DL7400 is accessed from the PC or workstation (login),  is displayed at the upper right corner of the screen.
- This function cannot be used when using the FTP client function, LPR client function, or Web server function or when performing file operations.
- The log list is cleared when the power is turned OFF.
- To use this function, you must configure TCP/IP in advance according to the procedure given in section 13.2.
- To activate the settings, you must power cycle the DL7400.

Explanation

The floppy disk drive, Zip disk drive, PC card drive, External SCSI device, or USB storage on the DL7400 can be accessed from a PC or workstation on the network via the Ethernet network. To access these drives, FTP client software is needed on the PC or workstation.

User Account

User Name

You can enter the user name using up to 15 characters. The default setting is "anonymous." The characters that can be used are all the ASCII characters on the keyboard.

Password

You can enter the password using up to 15 characters. The characters that can be used are all the ASCII characters on the keyboard.

Time Out

The connection to the network is automatically closed if there is no access to the DL7400 for the specified time. The default setting is 5 s. Set the timeout to a long value when using dedicated FTP client software.

13.7 Using the Web Server Function

You can use the Web server function on the DL7400 to display the screen image of the DL7400 on your PC's Web browser and perform file operations on the DL7400 using the keys displayed in the Web browser.

This section contains the following information.

- Overview of the Web server function -> See this page.
- System Requirements
 - PC environment -> See page 13-19.
 - DL7400 environment -> See page 13-20.
- Preparations for using the Web server function
 - Preparations on the DL7400 -> See page 13-21.
 - Preparations on the PC -> See page 13-22.
- Using the Web server function
 - Using the FTP server function -> See 13-26.
 - Performing data capture -> See page 13-27.
 - Displaying the measurement trend of waveform parameters -> See page 13-32.
 - Using control scripts -> See page 13-35.
 - Showing the log -> See page 13-37.
 - Showing the instrument information -> See page 13-39.
 - Viewing the link destination -> See page 13-40.

Overview of the Web Server Function

FTP Server Function (on a Web Browser)

View the list of files stored on the storage medium of the DL7400 (built-in storage medium) and transfer files to the PC.

Data Capture

The following operations can be performed.

- Change the display format of the DL7400 and display data that is acquired in the history memory.
- Display the screen image of the DL7400.
- Save the waveform data and setup data to the PC.
- Load the setup data stored on the PC into the DL7400.

Displaying the Measurement Trend of Waveform Parameters

Using the Excel function, display the trend of the selected waveform parameter values. The statistics of the measured values can also be computed.

Control Script

Control the DL7400 using communication commands (see the *Communication Interface User's Manual* (IM701450-17E)).

Log

Displays the past log of errors that occurred on the DL7400, GO/NO-GO determination, and action-on-trigger. Up to the 30 newest incidents are logged.

Instrument Information

Displays the model of the DL7400, the presence/absence of options, the ROM version (firmware version), etc.

Link

View the Web page for the DL7400.

System Requirements

PC Environment

OS

Microsoft Windows 98 Second Edition, Microsoft Windows NT 4.0, Microsoft Windows Millennium Edition, Microsoft Windows 2000 Professional, or Microsoft Windows XP Professional.

Internal Memory

64 MB or more recommended.

Communication Port

Ethernet communication port that supports 10BASE-T or 100BASE-TX. Use this communication port to connect the PC to the network.

Display

Display supported by the OS indicated above with a resolution of 1024 × 768 dots or higher.

Mouse or Pointing Device

Mouse or pointing device supported by the OS indicated above.

Files Required for the Web Browser

Of the Web server functions, the following files are required when using the data capture, measurement trend, or command script function. For the installation procedure on the PC, see "Installing Files Required for the Web Browser" (page 13-23).

Msvbvm60.dll

cmdlgjp.dll

comdlg32.ocx

Combinations of OS and Application Software That Have Been Tested

OS	Web Browser	Spreadsheet Software*
Windows NT	Internet Explorer 5.0	Microsoft Excel 97
Windows 98	Internet Explorer 5.0	Microsoft Excel 97
Windows 98 Second Edition	Internet Explorer 5.0	Microsoft Excel 97
Windows 2000 Professional	Internet Explorer 5.0/5.5/6.0	Microsoft Excel 97
Windows Millennium Edition	Internet Explorer 5.5/6.0	Microsoft Excel 97/2000/2002
Windows XP Professional	Internet Explorer 6.0	Microsoft Excel 2002

* The spreadsheet software is required when displaying the trend of waveform parameters of the Web server function.

DL7400 Environment

Connection to the Network

Connect the DL7400 to the network using the Ethernet. For the connection procedure, see section 13.1.

TCP/IP

Configure the network environment and IP address for communication using the Ethernet interface. For the setup procedure, see section 13.2.

Communication Interface

Set the communication interface to Network. For the procedure, see "Setting the Communication Interface to the Network" (page 13-21).

User Account

Set the user account used to access the DL7400 from the PC. For the setup procedure, see section 13.6.

Time Difference from GMT (Greenwich Mean Time)

When using the Web Server function, set the time difference from the GMT. Normally, the time difference is also set on the PC. Setting the time difference correctly allows the DL7400 and the PC to detect the local time correctly. Consequently, the PC will be able to detect whether a file is new when transferring or saving the file. For the setup procedure, see section 13.8.

Note

- Use Internet Explorer version 5.0 or later for the Web browser.
- The Web Server function contains software programs that have not been authenticated. Therefore, the following dialog box may appear. If it does, click Yes and install the software.

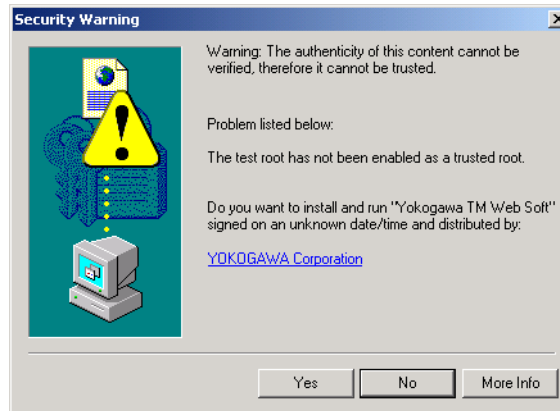

- You cannot open multiple Internet Explorer windows on the same PC and simultaneously use multiple identical features of the Web Server function.
- When using the storage function of the FTP server function (on the Web browser), data capture function, or the log display on the same PC, other Web server functions cannot be used.
- When using the storage function of the FTP server function (on the Web browser), data capture function, or the log display on a PC, other PCs cannot use the Web server function.
- The Web server functions use the Ethernet interface for communication. If the Ethernet interface is configured for controlling the DL7400 using a communication command (see the *Communication Interface User's Manual* (IM701450-17E)), the Ethernet interface cannot be used simultaneously.
- The Web server function cannot be used while the DL7440/DL7480 is printing or operating files (file operation from the front panel key or file transfer using the FTP server function), or while the Windows network drive is being used.

Preparations for Using the Web Server Function

Connecting the PC and the DL7400 to the Network

Connect the PC and the DL7400 to the network. For the connection procedure, see section 13.1.

Preparations on the DL7400

Setting the Communication Interface to Network

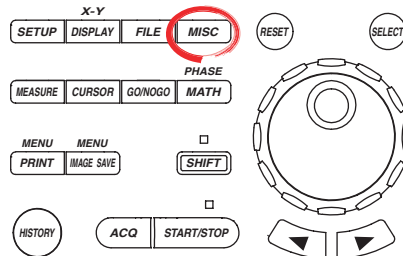

- To exit the menu during operation, press **ESC** located above the soft keys.
- For a description of the operation using a USB keyboard or a USB mouse, see section 4.3.

Turn ON the power to the DL7400. After the DL7400 boots up normally, carry out the following procedure.

1. Press **MISC**. The MISC menu appears.
2. Press the **Remote Control** soft key. The Remote Cntl menu appears.
3. Press the **Device** soft key. The Device menu appears.
4. Press the **Network** soft key. The Ethernet interface is selected for the communication interface.

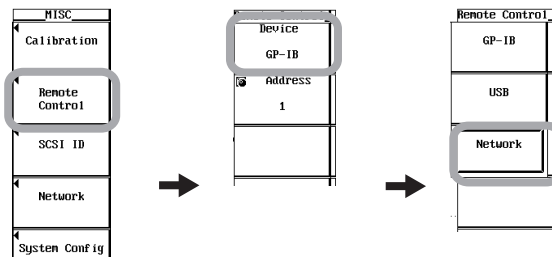

Setting Up the TCP/IP

5. Set the TCP/IP on the PC and the DL7400. For the procedure on the DL7400, see section 13.2.

Creating a User Account for Accessing the DL7400

6. Create the user account used to access the DL7400 from the PC. For the setup procedure, see section 13.6.

Note

The User Account in the menu that appears after step 4 is the user account that is used to control the DL7400 through communication commands via the Ethernet network. It is not the user account for using the Web server function.

Setting the Time Difference from GMT (Greenwich Mean Time)

7. Set the time difference between the location where the DL7400 is installed and GMT. For the setup procedure, see section 13.8.

Rebooting

8. To activate the TCP/IP, user account, and time difference settings, turn OFF the power switch. After a few seconds, turn ON the power switch to boot the DL7400.

Installing Files Required for the Web Server

- **Using the DL7400 and the PC While Connected to the Internet**

When you use the Web server function for the first time, the files required for the Web browser are installed automatically from the Microsoft Web site.

* If the three files (Msvbvm60.dll, cmdlgjp.dll, and comdlg32.ocx) are already installed in the PC when using the Web server function for the first time, step 7 is no required.

7. When the data capture, measurement trend, or command script function of the Web server function is used for the first time, three files, Msvbvm60.dll, cmdlgjp.dll, and comdlg32.ocx, are automatically downloaded from the Microsoft Web site and installed in the PC. At this point, a dialog box for confirming the installation appears. Click **OK**. You may need to restart the PC during the installation.

After the installation completes successfully, proceed to step 9 on the next page.



or



- **Using the DL7400 without Connecting to the Internet**

If the three files, `Msvbvm60.dll`, `cmdlgjp.dll`, and `cmdlg32.ocx`, are not installed in the PC when using the Web server function for the first time, install the files beforehand according to the following procedure.

7. Download the following file from the YOKOGAWA Web site (<http://www.yokogawa.co.jp/Measurement/F-SOFT/>).
DL7400 Series Web server function library installer
YOKOGAWA T&M Web Runtime: `ytmwrun.exe`
Data size: Approx. 1.5 MB
8. Double-click `ytmwrun.exe` after you have downloaded it. The installation of the aforementioned three files starts. Follow the on-screen instructions to install the files.

Checking the Web Browser (Internet Explorer) Security Settings

Check the security settings on Internet Explorer. The settings indicated in the table on the next page are defaults. If the settings on your browser do not match, set them back to the settings in the table on the next page. Otherwise, the Web server function cannot be used.

The following explanation is for Internet Explorer 5.5. For other versions, carry out equivalent steps accordingly.

9. Choose **Internet Options** from the **Tools** menu. The Internet Options dialog box opens.
10. Click the **Security** tab.
11. Select a Web content zone. The Web service zone varies depending on the network environment and browser settings. Check with your network administrator to select the zone.

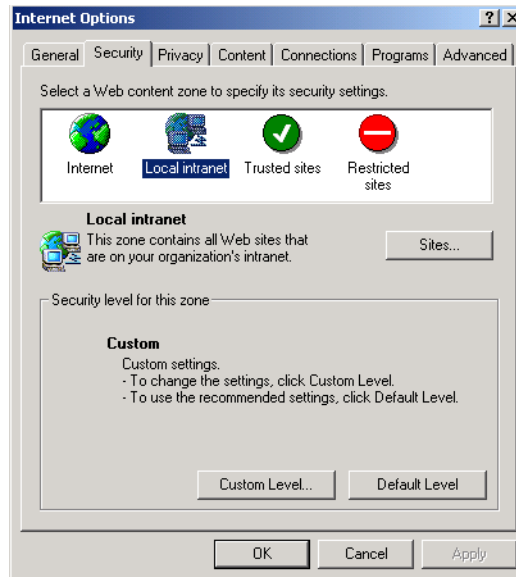

12. Click **Custom Level**. The Security Settings dialog box opens.

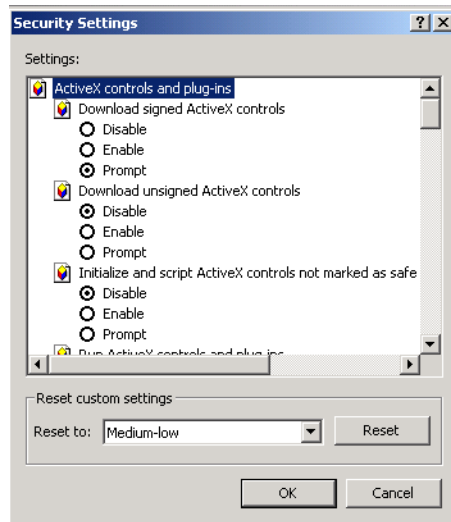

13. Enter the security settings as shown in the following table.

Item	Security Level
Run ActiveX controls and plug-ins	Enable
Script ActiveX controls marked safe for scripting	Enable
Download signed ActiveX controls	Prompt

14. Click **OK**.

Using the Web Server Function

Using the FTP Server Function (on a Web Browser)

Before using this function, check that the communication interface of the DL7400 is set to Network (see page 13-21).

Click the **FTP** icon on the Web server window. A window for viewing the storage media of the DL7400 (storage media view window) appears.

If the window does not appear, click the Refresh button on the Web browser. A login dialog box opens. Log in. The storage media view window appears.

Web server window

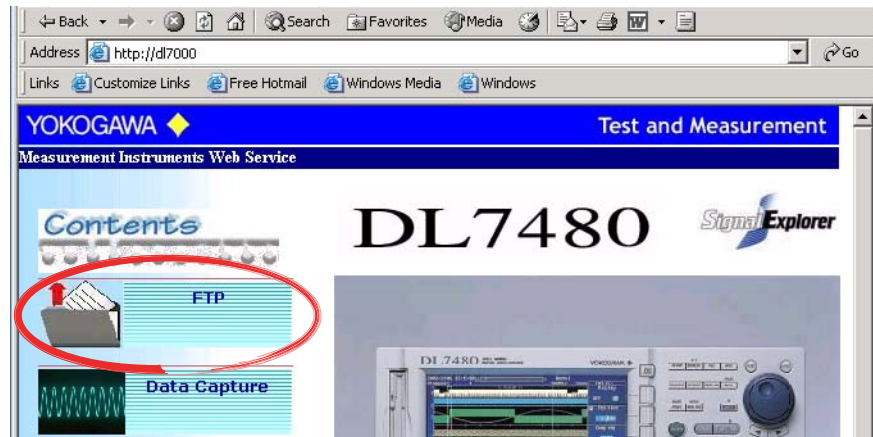

Window for Viewing the Storage Media

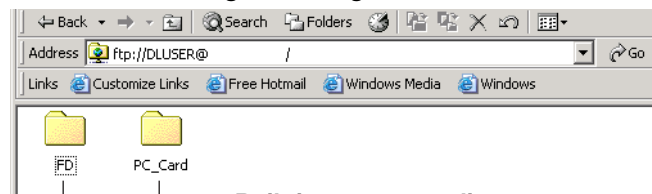

Built-in storage media
Depending on the product specifications, one of the following is displayed.

- Fd: Floppy disk
- Zip: Zip disk
- PC Card: PC card

- You can open folders on each storage medium and view the file list.
- You can select the files displayed in the window and transfer them to the PC.



Note

- Up to two PCs can log into the file transfer function simultaneously.
- You cannot manipulate the files simultaneously from two PCs.
- When the DL7400 is printing or operating on files (file operation from the front panel key or file transfer using the FTP server function), the Web server function cannot be used.
- To use the FTP server on a Web browser, a network user account on the DL7400 must be configured. For the procedure of setting user accounts, see steps 1 to 6 in section 13.6.
- An authentication login dialog box may appear on the Web browser when the FTP icon on the Web server window is clicked. If it does, enter the user name and password that were entered in section 13.6.

Performing Data Capture

Before using this function, check that the communication interface of the DL7400 is set to Network (see page 13-21).

Click the **Data Capture** icon on the Web server window. The Data Capture window showing the screen image of the DL7400 and the control panel that allows data saving and loading appears.

Web Server Window

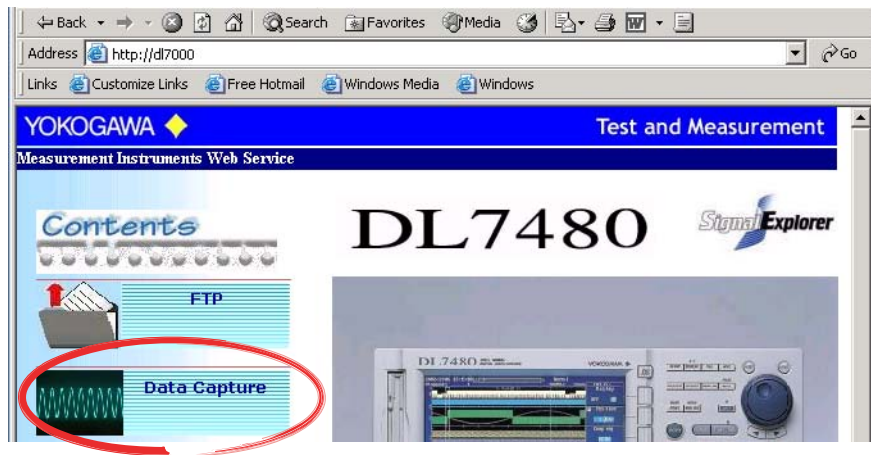

Dual Capture Window

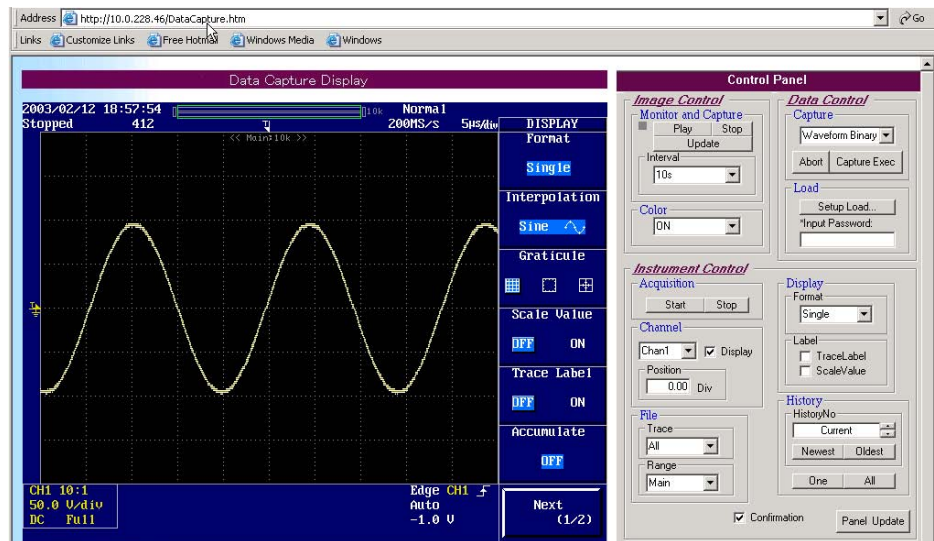

DL7440/DL7480 screen image

Control panel

Displaying and Saving the Screen Image (Image Control)

The screen image of the DL7400 can be displayed on the PC screen and saved.

- **Updating the Screen Image (Monitor & Capture)**

Play

Click **Play**. The update indicator illuminates in green, and the updating of the screen image at the specified display update interval starts (see below).

Stop

Click **Stop**. The update indicator turns off, and the updating of the screen image stops.

Update

Click **Update**. The screen image is updated.

Interval

Set the display update interval to 10 s, 30 s, or 60 s.

Update indicator

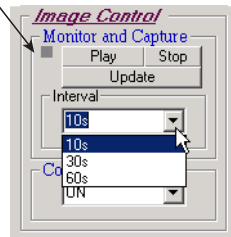

- **Selecting the Display Color of the Screen Image (Color)**

Select the display color from ON, OFF, Reverse, and Gray. For a description of the displayed information for each setting, see the explanation in section 12.12.

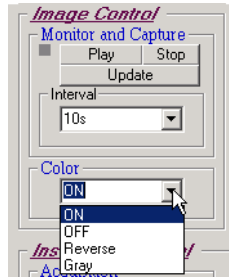

Note

The time it takes to display the screen image on the PC varies depending on the color setting. In decreasing order, the color settings are ON, Reverse, Gray, and OFF.

- **Saving the Screen Image in the PC**

Right-click on the displayed screen image. The following shortcut menu appears.

Choose **Save Picture As** to save the current screen image.

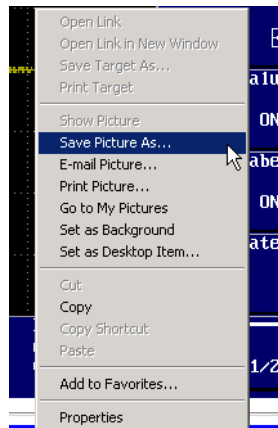

Saving Data in the PC and Loading Setup Data from the PC into the DL7400 (Data Control)

- **Saving Data in the PC (Capture)**

Data Type

Select the type of data to be saved from Waveform Binary, Waveform ASCII, Waveform Float, Setup, and Measure. For details on the settings, see the explanations in section 12.7, 12.8, and 12.10.

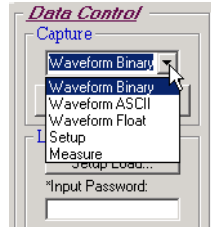

Capture Exec

Using the dialog box that appears when you click Capture Exec, set the save destination and file name and save the data.

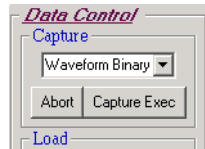

Abort

To abort the save operation while data is being saved, click **Cancel** on the dialog box. Then, click **Abort** on the Control Panel.

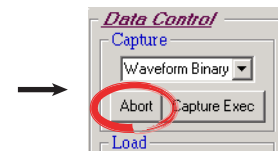
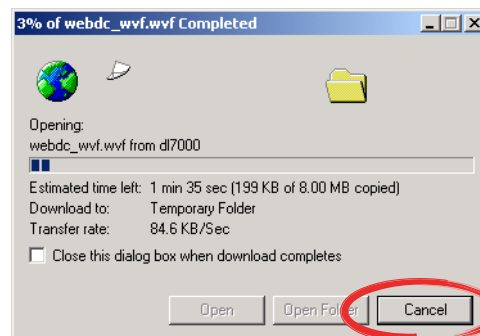

You must enter a password to abort. For details, see “Input Password” in the next section.

- **Loading the Setup Data from the PC into the DL7400 (Load)**

Input Password

Enter the password (see page 13-22) that you used to log into the Web server (DL7400). If the user name of the user account is set to “anonymous” (default setting), the password is not required.

Setup Load

Click **Setup Load**. The Open dialog box opens. Select the setup data file you wish to load and click OK to execute the load operation.

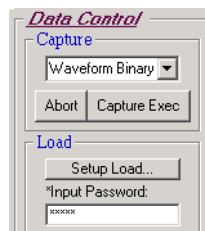

Note

- Depending on the operation condition of the DL7400 (such as when measurement is in progress), data save and setup data load operations may not be possible.
 - When data is being saved or the setup data is being loaded, other Web server functions cannot be used.
 - When loading the setup data or when aborting the save operation, a temporary file (zzzftpzzztmpzzz.bat) is created in the start directory of the Internet Explorer. After the operation is complete, the temporary file will be deleted.
 - If you execute the data save operation when there is no waveform data or waveform parameter, an error is displayed on the DL7400 screen, and a 0-byte file is saved.
-

Controlling the DL7400 (Instrument Control)

You can use the PC to set the display format and the data save conditions of the DL7400. The settings entered here apply to the display format and save conditions used to save the data on the previous page.

- **Starting/Stopping the Waveform Acquisition (Acquisition)**

Start

Click **Start**. Acquisition of waveform data starts.

Stop

Click **Stop**. Acquisition of waveform data stops.

- **Turning ON/OFF the Waveform Display and Setting the Vertical Position (Channel)**

Selecting the Target Waveform

From the channel box, select the channel for turning ON/OFF the display and setting the vertical position.

Chan1 to Chan8 (channels 1 to 8)

* Chan1 to Chan4 (channels 1 to 4) on the DL7440.

Display ON/OFF

To display the waveform of the selected channel (turn it ON), select the Display check box. Clear the check box to not display the waveform of the selected channel (OFF).

Vertical Position

Set the vertical position of the waveform of the selected channel. For a description of the selectable range of the vertical position, see section 5.3.

- **Setting the Display Format (Display)**

Display Format

You can set the number of divided windows for displaying waveforms.

Single, Dual, Triad, Quad, Hexa, and Octal (can be used on the LD7480)

* For the meanings of the selections, see the explanation in section 8.1.

Turning ON/OFF the Display of the Waveform Labels and Scale Values (Label)

Display Waveform Label (TraceLabel)

To display the labels of the displayed waveforms, select the TraceLabel check box. Clear the check box to not display the labels.

Turning ON/OFF the Display of the Upper and Lower Limits of the Displayed Waveforms (ScaleValue)

To display the upper and lower limits of the displayed waveforms, select the ScaleValue check box. Clear the check box to not display the upper and lower limits.

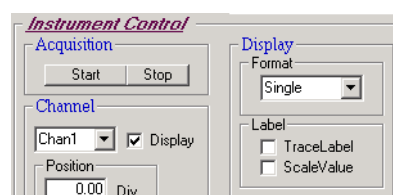

- **Selecting the Waveforms to Be Saved (File)**

- **Selecting the Target Waveform (Trace)**

You can select the waveforms to be saved using the trace box.

All (all waveforms), 1 to 8 (channels 1 to 8)¹, Math1, Math2 (computed waveforms), Pod A², and Pod B²

- 1 All, 1 to 4 (channels 1 to 4) on the DL7440.
- 2 Pod A and Pod B apply if the logic input option is installed.

- **Selecting the Save Area (Range)**

Select the area in which the target waveform to be saved is displayed.

Main, Z1, Z2, or Z1_Z2 (displayed as Z1&Z2 on the DL7400 menu)

* For the meanings of the selections, see the explanation in section 12.8.

- **Setting the History Waveform Display**

- **Selecting by History Waveform Number (History No.)**

Specify the number of the history waveform to be displayed.

- **Selecting the Newest or Oldest Data**

You can specify the newest or the oldest waveform among the history waveforms to be displayed.

- **Selecting One or All**

One

Click One. A single history waveform that is selected by the history waveform number or selected by newest or oldest is displayed.

All

Click All. All the history waveforms are displayed.

- **Updating the Setup Condition (Panel Update)**

Click **Panel Update**. The control panel settings on the Data Capture window (PC) are updated to match the newest setup condition on the DL7400.

- **Automatically Updating the Screen Image (Confirmation)**

Select the **Confirmation** check box. The screen image is automatically updated using the same conditions as Color-OFF when you change the settings of the above items that would cause the screen image to change. Clear the check box to not update automatically.

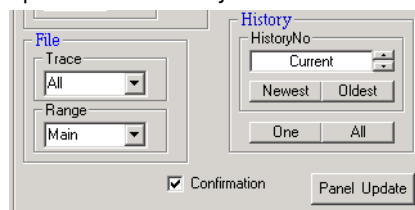

Note

- You cannot set the history waveform display when the DL7400 is making measurements.
- Setting the history waveform display when there are no history waveforms results in error.
- The timeout time on the PC when controlling the DL7400 is 30 s. Depending on the DL7400 condition, a timeout may occur preventing you from controlling the DL7400.

Displaying the Measurement Trend of Waveform Parameters

Before using this function, check that the communication interface of the DL7400 is set to Network (see page 13-21).

Click the **Measurement Trend** icon on the Web server window. The Measurement Trend window in which the trend display of the waveform parameter values can be set appears.

Web Server Window



Measurement Trend Window

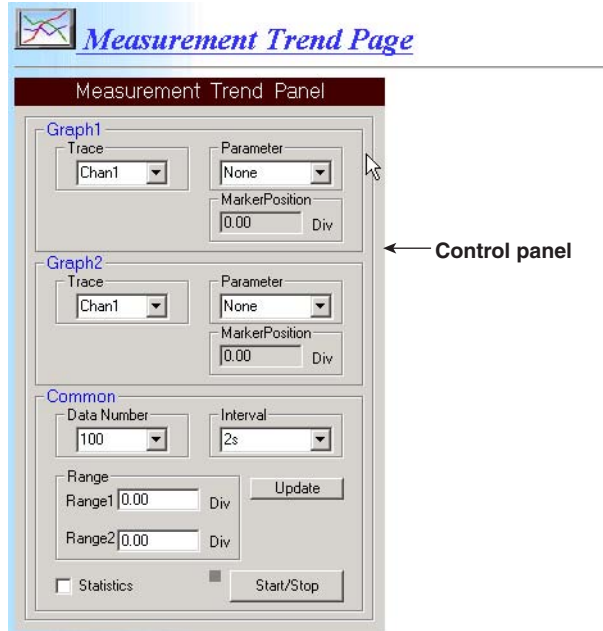

Note

- This function retrieves the selected waveform parameter values at the selected retrieve interval from the DL7400 into the PC and displays the trend. To display the retrieved measurement values and trend, Microsoft Excel 97 or later must be installed on the PC.
- If the measured value of a waveform parameter is not a normal number (Not A Number), the cell displaying the measured value on Microsoft Excel is set to blank.
- This function cannot be used in roll mode.

Setting the Trend Display Conditions

- **Selecting the Waveform Parameter to Be Displayed (Graph 1 and Graph 2)**

You can display two trend graphs. For each graph, you can specify the trend target waveform and the waveform parameter. When the waveform parameter is Marker, you can set the Marker Position.

Selecting the Target Waveform (Trace)

From the Trace box, select the target waveform for the trend display

Chan1 to Chan8 (channels 1 to 8), Math1 to Math8 (computed waveforms)

* Chan1 to Chan4 (channels 1 to 4), Math1, and Math2 on the DL7440.

Selecting the Waveform Parameter

From the Parameter box, select the target waveform parameter of the trend display (same expression as the communication command). For the meanings of the waveform parameters and the marker cursor, see the explanation in section 10.5 or 10.6.

Parameter	DL7400 Menu	Parameter	DL7400 Menu
None	Not selected	NOVERSHOOT	-OShot
AVERAGE	Avg	NWIDTH	-Width
AVGFREQ	AvgFreq	PERIOD	Period
AVGPERIOD	AvgPriod	PNUMBER	Pulse
BWIDTH1	Burst1	POVERSHOOT	+OShot
BWIDTH2	Burst2	PTOPEAK	P-P
DELAY (For a detail setting, use Delay Setup on the DL7400)	Delay	–	–
DUTYCYCLE	Duty	PWIDTH	+Width
FALL	Fall	RISE	Rise
FREQUENCY	Freq	RMS	Rms
HIGH	High	SDEVIATION	Sdev
LOW	Low	TY1INTEG	Int1TY
MAXIMUM	Max	TY2INTEG	Int2TY
Marker(M1<2>) (marker cursor for cursor measurements)	M1<2>	XY1INTEG	Int1XY
MINIMUM	Min	XY2INTEG	Int2XY

Setting the Marker Position

Set the marker position if Marker(M1) or Marker(M2) is selected as the waveform parameter.

- **Setting the Conditions for Retrieving the Measured Values of Waveform Parameters (Common)**

Number of Displayed Measured Values (Data Number)

Select the number of measured values (measured values retrieved from the DL7400 into the PC) to be displayed in the cells of Excel from the following: 10, 20, 50, 100, 200, and 500. If the number of measured values exceeds the selected number, the values are cleared from the oldest values to display the newest measured values.

Retrieve Interval

Select the retrieve interval from the following: 2 s, 5 s, 10 s, 30 s, and 60 s. However, of the selected waveform parameters, select the interval to match the longest parameter cycle measured on the DL7400.

Measurement Range

You can set the range on the time axis for measuring the waveform parameter. Range1 and Range2 are the start and end points, respectively. The selectable range is ± 5 divisions, and the resolution varies depending on the specified record length. However, the measurement start point cannot be set to the same point as the measurement end point or to a value to the right of the measurement end point.

Turning ON/OFF the Statistics Display

- Displays the statistics (Max, Min, and Average) of the waveform parameters retrieved into the PC.
- To display the statistics, select the Statistics check box. Clear the check box to not display the statistics.
- The number of measurement values displayed in the cell of Excel is up to the number specified in "Number of Displayed Measured Values (Data Number) on the previous page. The statistics are determined on all the measured data since the trend display was started, not on only the displayed measured values.

Updating the Setup Condition

Click **Update**. The Marker Position and Range that are set on the control Panel of the measurement trend window are updated to match the newest setup conditions of the DL7400.

Starting/Stopping the Trend Display of the Measured Values of the Waveform Parameters

- **Start**
Click **Start/Stop**. The indicator illuminates in yellow, and retrieval of the measured values of waveform parameters starts at the specified retrieve interval. At the same time, Microsoft Excel starts, and the measured values and trend graphs are displayed/drawn. If the statistical display is turned ON, the statistics are also displayed. The retrieval of the measured value of waveform parameter continues until the operation is stopped.
- **Stop**
 - Click **Start/Stop** while the trend display is in progress. The indicator turns OFF, and the display and drawing of the measured values and trend graph stop.
 - If you attempt to save the data to a file or close Excel while the trend display is in progress, a runtime error occurs. In this case, select **No** on the runtime error dialog box and close the dialog box. Then, click Start/Stop on the measurement trend window to stop the trend display. After stopping the trend display, save the file or close Excel.

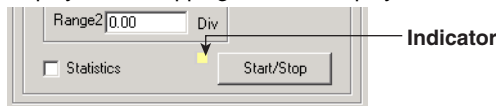

Display Example of Measured Values, Trend Graphs, and Statistics

	A	B	C	D	E	F	G	H	I	J	K
1	Measurement Trend										
2											
3	Chan1 AVERAGE	Chan1 AVERAGE									
4	-2.100E-02	-1.891E-02									
5	-2.175E-02	-1.100E-02									
6	-1.050E-02	-1.433E-02									
7	-1.383E-02	-2.333E-02									
8	-2.150E-02	-1.117E-02									
9	-2.058E-02	-1.667E-02									
10	-1.358E-02	-2.066E-02									
11	-2.500E-02	-1.800E-02									
12	-1.608E-02	-2.458E-02									
13	-1.042E-02	-2.775E-02									
14	-1.941E-02	-6.416E-03									
15	-2.341E-02	-1.800E-02									
16	-2.708E-02	-1.308E-02									
17	-1.333E-02	-1.217E-02									
18	-1.350E-02	-2.191E-02									
19	-1.700E-02	-1.075E-02									
20	-1.158E-02	-1.766E-02									
21	-1.716E-02	-1.725E-02									
22	-1.200E-02	-2.050E-02									
23	-1.592E-02	-8.999E-03									
24	-1.592E-02	-5.000E-03									
25	-1.042E-02	-1.708E-02									
26	-2.150E-02	-2.166E-02									
27	-2.050E-02	-1.958E-02									
28	-1.083E-02	-1.192E-02									
29											
30											
31											
32											
33											
34											
35											

Trend graph (Graph1) Chan1 AVERAGE

*Current Value : -1.083E-02

Newest measured value

*Statistics1

Count:	25
Max:	-1.042E-02
Min:	-2.708E-02
Average:	-1.695E-02

← Statistics

Trend graph (Graph2) Chan1 AVERAGE

*Current Value : -1.192E-02

Newest measured value

*Statistics2

Count:	25
Max:	-5.000E-03
Min:	-2.775E-02
Average:	-1.634E-02

← Statistics

Using Control Scripts

Before using this function, check that the communication interface of the DL7400 is set to Network (see page 13-21).

Click the **Control Script** icon on the Web server window. The Control Script window used to send communication commands (see the *Communication Interface User's Manual* (IM701450-17E)) to the DL7400 and display the responses from the DL7400 appears.

Web Server Window



Control Script Window

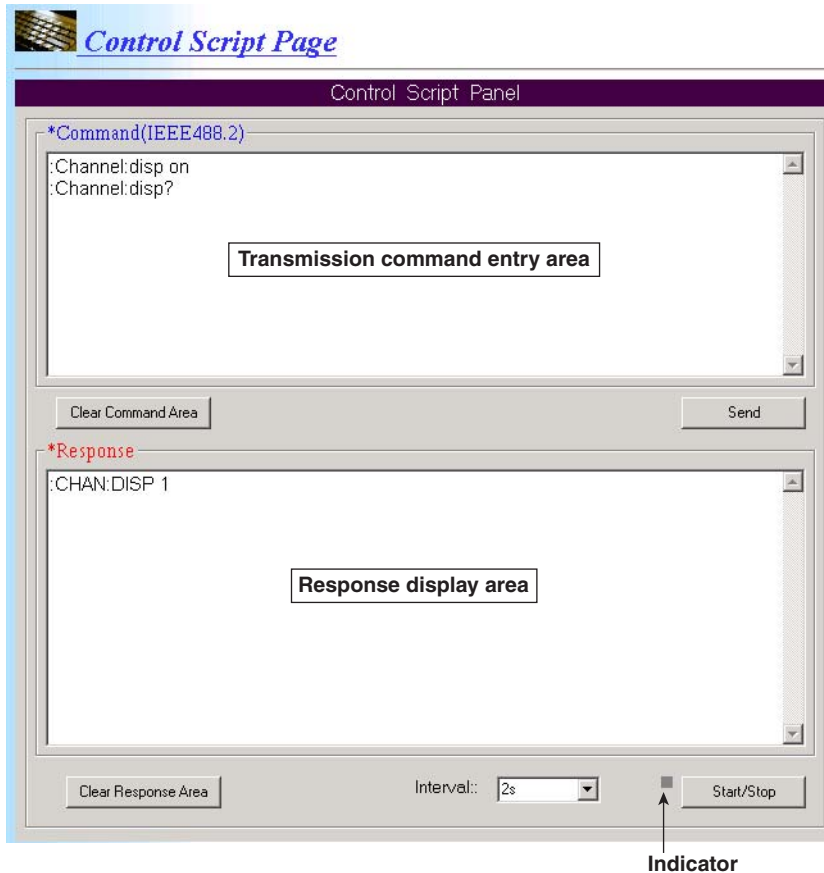

Sending Commands (*Command IEEE 488.2)

- **Entering the Transmission Commands**
Enter the commands in the transmission command entry area. The maximum number of input characters is 50,000 (50 KB).
- **Sending Commands**
Click **Send**. The commands in the transmission command entry area are sent collectively in the order displayed in the area.
- **Clearing the Entered Commands (Clear Command Area)**
Click **Clear Command Area**. All the commands in the transmission command entry area are cleared.

Displaying the Responses from the DL7400 (*Response)

Receives and displays the responses from the DL7400 against the commands (queries) sent to the DL7400 using the control script function.

- **Clearing the Responses (Clear Response Area)**
Click **Clear Response Area**. All the responses received from the DL7400 that are displayed in the response display area are cleared.

Sending Commands Periodically and Displaying Responses

Periodically sends the commands in the transmission command entry area. If commands (queries) that request responses from the DL7400 are sent, the responses from the DL7400 are displayed in the response display area.

- **Setting the Transmission Interval**
Select the command transmission interval.

2s, 5s, 10s, 30s, or 60s

- **Starting Periodic Transmission (Start)**
Click **Start/Stop**. The indicator illuminates in yellow, and the command transmission and response display start at the specified transmission interval.
- **Stopping Periodic Transmission (Stop)**
Click **Start/Stop** while the periodic transmission is in progress. The indicator turns OFF, and the command transmission and response reception/display stop. However, if the last command before stopping the periodic transmission was a query command, the response to that command is displayed in the response display area.

Note

- If a wrong command is sent, the error message is not automatically displayed in the Control Script window. The error code and message are displayed by entering the “:status:error?” command in the transmission command input area. You can also confirm the error on the screen image displayed using the data capture function and also on the DL7400 screen.
 - Binary data cannot be received or displayed.
 - The transmission timeout is 30 s. Transmission and reception exceeding 30 s results in a timeout error. If all the commands specified in the transmission command entry area is sent, and the responses to the commands are not received within 30 s, a timeout error occurs.
-

Displaying the Log

Before using this function, check that the communication interface of the DL7400 is set to Network (see page 13-21).

Click the **Log** icon on the Web server window. The Log window that can display the past log of errors that occurred on the DL7400, GO/NO-GO determination, and action-on-trigger appears. Up to the 30 newest incidents are logged. Logs older than the most recent 30 are not displayed.

Web Server Window

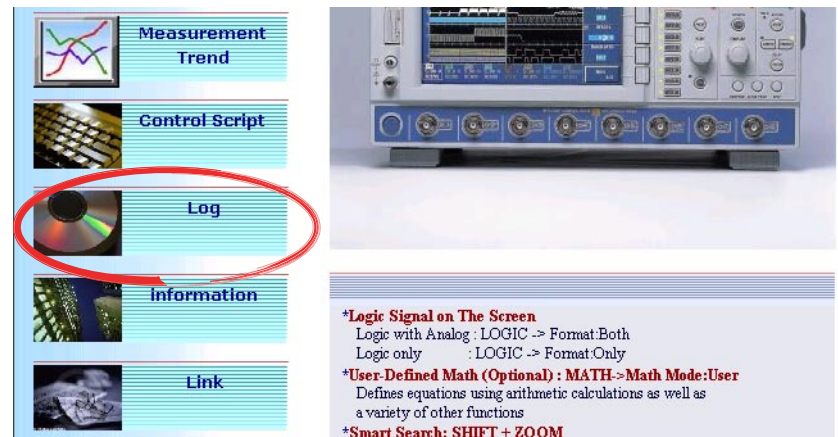

Log Window

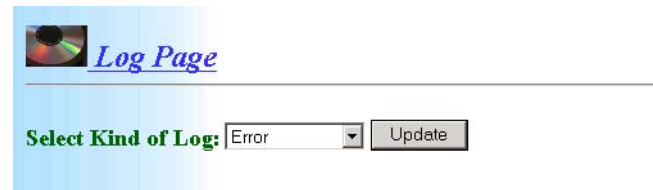

Displaying the Log

- **Selecting the Log Type (Select Kind of Log)**

From the list box, select the item for displaying the log.

Error (log of errors that occurred on the DL7400)

Go/Nogo (log of GO/NO-GO determination)

For the setup procedure for the GO/NO-GO determination, see sections 10.9 and 10.10.

Action Trigger (log of action-on-triggers)

For the setup procedure for the action-on-trigger, see section 6.16.

- **Updating the Log (Update)**

Click **Update**. The selected log is displayed. If the selected type of log is the same as that of the log being displayed, the log is updated.

13.7 Using the Web Server Function

Log Display Example

The following figure shows an example displaying the log of GO/NO-GO determination.

Displays "Executing..." while GO/NO-GO determination is in progress or when action-on-trigger is in execution.

No.	Date	Time	Factor	Action
5	2003/02/13	11:42:01.05	Param1(Ch1,Max) Param2(Ch1,Min)	Buzzer_File: /FD0/0009.WVF ,Image: /FD0/0006.TIF ,Mailto:
4	2003/02/13	11:40:59.00	Param1(Ch1,Max) Param2(Ch1,Min)	Buzzer_File: /FD0/0008.WVF ,Image: /FD0/0005.TIF ,Mailto:
3	2003/02/13	11:39:58.45	Param1(Ch1,Max) Param2(Ch1,Min)	Buzzer_File: /FD0/0007.WVF ,Image: /FD0/0004.TIF ,Mailto:
2	2003/02/13	11:38:59.40	Param1(Ch1,Max) Param2(Ch1,Min)	Buzzer_File: /FD0/0006.WVF ,Image: /FD0/0003.TIF ,Mailto:
1	2003/02/13	11:37:58.12	Param1(Ch1,Max) Param2(Ch1,Min)	Buzzer_File: /FD0/0005.WVF ,Image: /FD0/0002.TIF ,Mailto:

If screen image data or waveform data files are being saved in the GO/NO-GO determination or action-on-trigger, the files can be saved on the PC from the Log display window.

The drive is indicated in the log as follows.

CA0	PC Card
FD0	Floppy disk
ZP0	Zip disk
SC5	SCSI device with the ID number set to 5*
SC5-1	Partition 1 of a SCSI device whose ID number is 5*
ND0	Network drive (when the Ethernet interface option is installed)
US <input type="checkbox"/> - <input type="checkbox"/>	USB strage
	Partition number (or LUN (Logical Unit Number))
	Address number

* When a SCSI device whose ID number is 5 is connected.

Note

- When the DL7400 is printing or operating files (file operation from the front panel key or file transfer using the FTP server function), files cannot be saved on the PC. In addition, other Web server functions cannot be used while saving files.
- Files on the network drive (NetWork) cannot be saved to the PC.

Displaying Instrument Information

Before using this function, check that the communication interface of the DL7400 is set to Network (see page 13-21).

Click the **Information** icon on the Web server window. The Information window that displays the DL7400 model (Model), the maximum record length available (Record Length), the storage media type (Media), the presence of options (Option), ROM version (firmware version, software version, and product ID), and other information appears.

Web Server Window

***Logic Signal on The Screen**
 Logic with Analog : LOGIC -> Format:Both
 Logic only : LOGIC -> Format:Only

***User-Defined Math (Optional) : MATH->Math Mode:User**
 Defines equations using arithmetic calculations as well as a variety of other functions

***Smart Search: SHIFT + ZOOM**

Information Window

Information Page

System Overview

Item	Contents
Model	701480
RecordLength	Max16MW(8MW/CH)
Media	FDD(-J1),PC CARD,SCSI(/C7)
Option	Printer:Yes
	Logic:Yes
	Ether:Yes(MAC>000064_846_044)
	Math UserdefNo
	Others:No
Soft Version	1.01
Product ID	VxcG1VJg

Viewing the Link

Before using this function, check that the communication interface of the DL7400 is set to Network (see page 13-21).

Click the **Link** icon on the Web server window. You can view the Web page for the DL7400.

Web Server Window

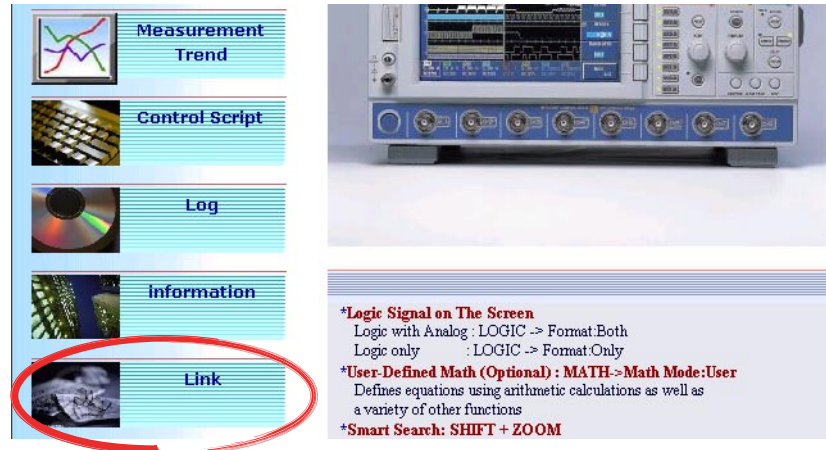

Web Page Example (English Web Page)

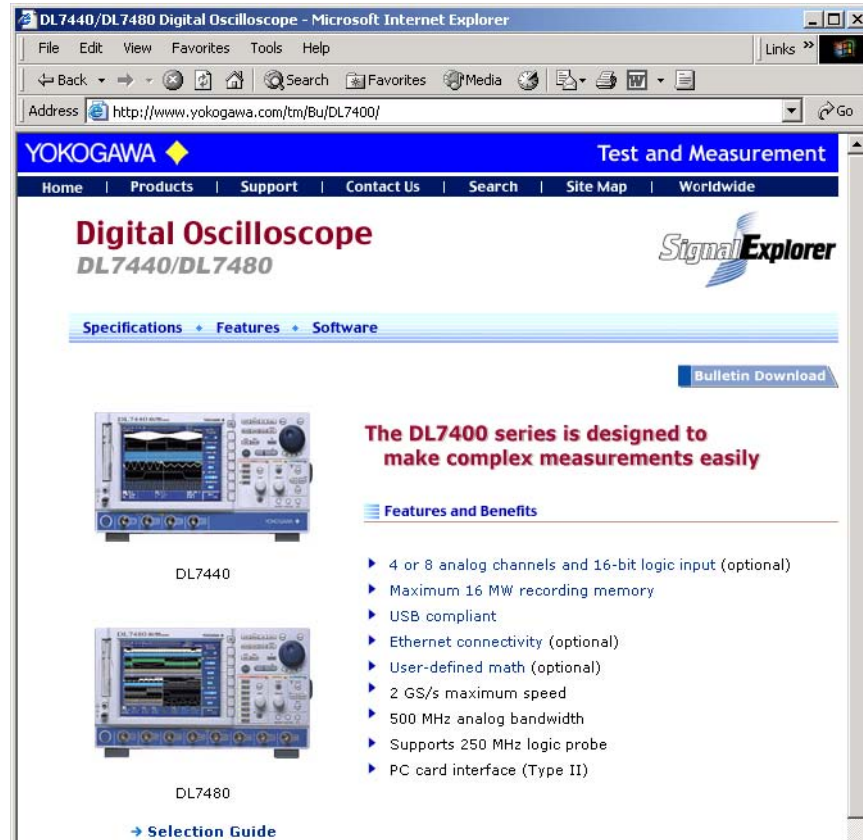

Note

- To use the link function, the PC must be connected to the Internet.
- If the message language of the DL7400 is set to English, the English Web page is displayed; if the message language is set to Japanese, the Japanese Web page is displayed. For the setup procedure for the message language, see section 15.1.

13.8 Setting the Time Difference from GMT (Greenwich Mean Time)

Procedure

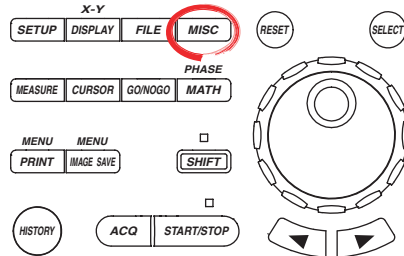

- To exit the menu during operation, press **ESC** located above the soft keys.
- In the procedural explanation below, the term *jog shuttle* & **SELECT** refers to the operation of selecting/setting items and entering values using the *jog shuttle* and **SELECT** and **RESET** keys. For details on this operation, see sections 4.1 or 4.2.
- For a description of the operation using a USB keyboard or a USB mouse, see section 4.3.

Setting the Time Difference from GMT (Greenwich Mean Time)

1. Press **MISC**. The MISC menu appears.
2. Press the **Network** soft key. The Network menu appears.
3. Press the **Others** soft key. The Others dialog box opens.

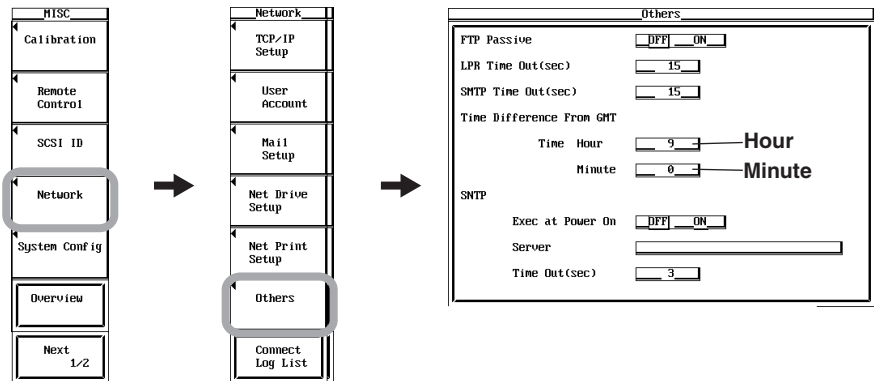

4. Use *jog shuttle* & **SELECT** to set the Time Hour of Time Difference From GMT in the range of -12 to 13.
5. Likewise, set the Minute of Time Difference From GMT in the range of 0 to 59.

Note

Minute can be specified only if Time Hour is set in the range of -11 to 12. (Minute cannot be specified if Time Hour is set to -12 or 13.)

Setting SNTP (Simple Network Time Protocol) (Firmware Version 1.30 or later)

6. Use the *jog shuttle* to set Exec at Power On to ON or OFF.
7. Use *jog shuttle* & **SELECT** to enter Server (IP address of the SNTP server).
8. Use *jog shuttle* & **SELECT** to enter Time out in the range of 1 to 60 (s).

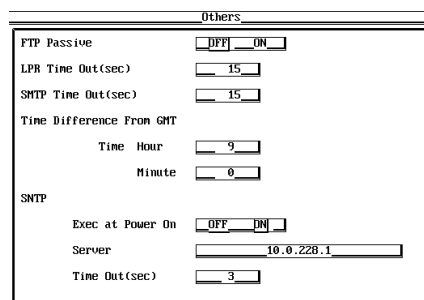

Explanation

Set the time difference from GMT (Greenwich Mean Time). Make sure to set this value if you are using the Web server function.

Setting the Time Difference from GMT (Greenwich Mean Time)

Set the time difference in the range of –12 hours 00 minutes to 13 hours 00 minutes. For example, Japan standard time is ahead of GMT by 9 hours. In this case, set Hour to 9 and Minute to 00.

Checking the Standard Time

Check the standard time for the region where the DL7400 is to be used using one of the following methods.

- Check the date and time settings on your PC.
- Check the site at the following URL:<http://www.worldtimeserver.com/>

Note

The DL7400 does not support daylight savings time. To set the daylight savings time, adjust the time difference from GMT.

Setting SNTP

If Exec at power On is ON, the DL7400 retrieves date/time information from an NTP server or SNTP server connected to the network when the power to the DL7400 is turned ON.

Note

- If the time difference from GMT (Greenwich Mean Time) is specified, the time is set to a value derived by calculating the difference between the time retrieved from the SNTP server and the time difference.
 - The date/time information can also be retrieved from an NTP server or SNTP server when you are setting the date/time on the DL7400. For details, see section 3.7, "Setting the Date and Time."
 - If you do not wish to retrieve date/time information from the NTP server or SNTP server, leave the IP address blank.
-

13.9 Checking the Presence of the Ethernet Interface (Optional) and the MAC Address

Procedure

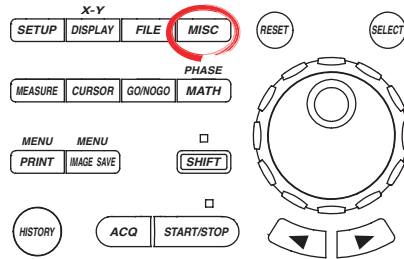

- To exit the menu during operation, press **ESC** located above the soft keys.
- For a description of the operation using a USB keyboard or a USB mouse, see section 4.3.

1. Press **MISC**. The MISC menu appears.
2. Press the **Overview** soft key. The Overview window opens. Pressing a panel key other than the Overview soft key clears the Overview window.

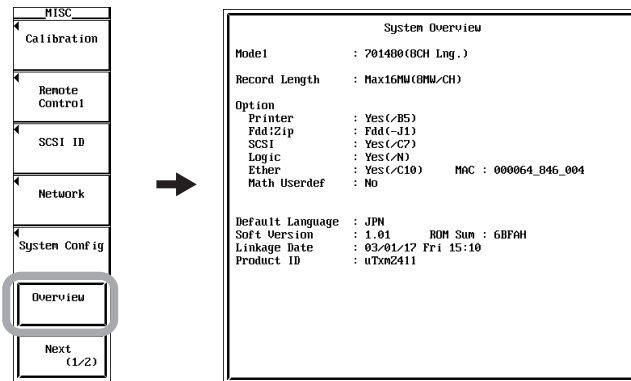

When Ether:Yes(/C10) appears for the Option item in the Overview window, this indicates that the Ethernet interface is installed. The information displayed on the right (MAC:000064_846_004 in the example) is the MAC address.

Note

- Ether:Yes(/C10) is displayed only if the Ethernet interface option is installed.
- If XXXXXX_XXX_XXX is displayed for the MAC address, contact your nearest YOKOGAWA dealer.

Explanation

You can check the presence of the Ethernet interface (optional) and the MAC address. MAC address is a unique address that is pre-assigned to the DL7400.

The Presence of the Ethernet Interface (Optional)

Displayed in the Ether section of the Overview window.

Yes	The Ethernet interface is installed.
No	The Ethernet interface is not installed.

MAC Address

MAC address is a unique address that is pre-assigned to the DL7400. It is required in identifying the instruments on the network.

13.10 Setting the FTP Passive Mode and LPR/SMTP Timeout

Procedure

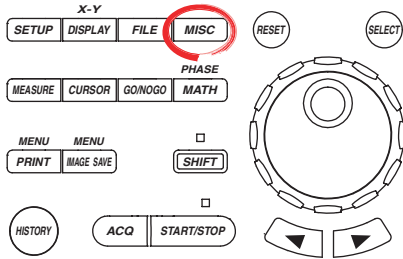

- To exit the menu during operation, press **ESC** located above the soft keys.
- In the procedural explanation below, the term *jog shuttle & SELECT* refers to the operation of selecting/setting items and entering values using the **jog shuttle** and **SELECT** and **RESET** keys. For details on this operation, see sections 4.1 or 4.2.
- For a description of the operation using a USB keyboard or a USB mouse, see section 4.3.

1. Press **MISC**. The MISC menu appears.
2. Press the **Network** soft key. The Network menu appears.
3. Press the **Others** soft key. The Others dialog box opens.

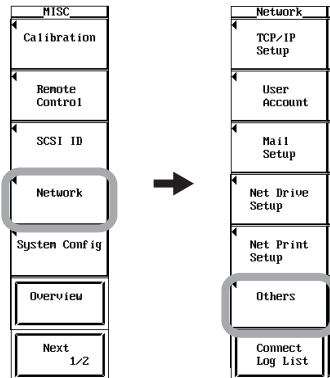

Turning ON/OFF FTP the Passive Mode

4. Use **jog shuttle & SELECT** to select ON or OFF.

Setting the LPR Timeout Time

4. Use **jog shuttle & SELECT** to set LPR Time Out.

Setting the SMPT Timeout Time

4. Use **jog shuttle & SELECT** to set SMTP Time Out.

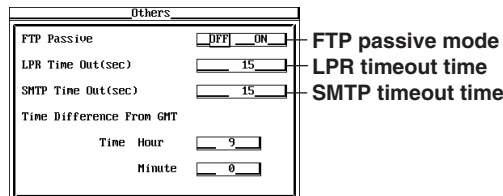

Explanation

You can enter special settings related to the FTP client, LPR, and SMTP. Normally, these parameters do not need to be specified.

Turning ON/OFF the FTP Passive Mode

Turn this function ON when using the DL7400 behind a firewall* that requires the passive mode. The default setting is OFF.

* A firewall is furnished on a system that has security features. It prevents intrusion from the outside into the network system.

Setting the LPR Timeout Time

The DL7400 closes the connection to the printer if there is no response for a certain period of time (timeout time) while it attempts to access the printer. The selectable range is 0 to 3600 s. The default setting is 15 s.

Setting the SMTP Timeout Time

When a mail server is accessed from the DL7400 and connection cannot be established after a certain period of time (timeout time), the DL7400 decides that the connection to the mail server is not possible and closes the connection. The selectable range is 0 to 3600 s. The default setting is 15 s.

13.11 Using the Storage Medium as a Windows Network Drive (Firmware Version 1.30 or Later)

The external storage medium of the DL7440/DL7480 can be used as a network drive on a PC running Windows XP.

Procedure

Setting the DL7440/DL7480

Setup TCP/IP and user account and connect to the network according to the procedures given in section 13.2, "Setting Up TCP/IP" and 13.6, "Accessing the DL7400 from a PC or Workstation (FTP Server Function)."

Registering the Network Drive on the PC

1. Open **My Network Places**.
2. From the **Tools** menu, choose **Map Network Drive**. The Map Network Drive dialog box opens.
3. Select the drive to be mapped from the **Drive** list box.
4. In the **Folder** text box, type the IP address of the DL7400 in the following format: `http://DL7400 IP address/dav/`.

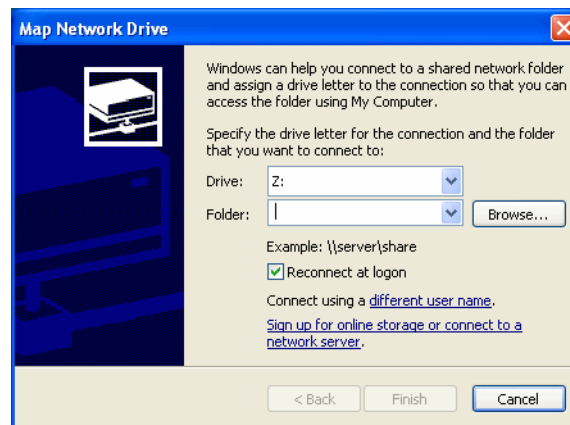

5. Click **Finish**.
If an user account is set up with the FTP server function, a dialog box for entering the user name and password opens (see section 13.6, "Accessing the DL7400 from a PC or Workstation (FTP Server Function)"). If an user account is not set up, the DL7400 is registered as a network drive.
6. If the dialog box for entering the user name and password opens, enter the user name and password that were created using the User Account function of the DL7400, and then click **OK**.



Disconnecting the DL7400 Mapped as a Network Drive

1. From the **Tools** menu, choose **Disconnect Network Drive**. The Disconnect Network Drives dialog box opens.
2. Select the network drive to disconnect and click **OK**.

Explanation

Network Drives

You can map the DL7440/DL7480 as a network drive on the PC by carrying out the procedure described above. In doing so, you will be able to access the various types of data stored on the DL7440/DL7480 storage medium (PC card or Zip disk) from a software application running on the PC.

Note

- Do not change the contents of the DL7440/DL7480 drive (including the contents of the drives connected via the SCSI) from the PC. Reading the contents of the drive is allowed.
 - Never perform the following operations.
 - Delete files on the DL7440/DL7480 drive from the PC.
 - Add files on the DL7440/DL7480 drive from the PC.
 - Change the directory structure of the DL7440/DL7480 drive from the PC.
 - If you attempt to move a large file from the PC to the DL7440/DL7480, the file may be lost due to the limitations of Windows.
 - You cannot manipulate the files simultaneously from multiple PCs.
 - You cannot view a directory containing 500 or more files.
 - You cannot use the WebDAV function simultaneously with the Web server function.
 - When manipulating files using the network drive function, do not perform other network functions such as the FTP client/server function or Web server function. If you do, the DL7440/DL7480 or the PC may become unstable.
 - The DL7440/DL7480 can be mapped as a network drive only on Windows XP.
-

Characters That Can Be Used

This function uses the WebDAV client function on Windows and the WebDAV server function on the DL7400. The characters that can be used on the WebDAV server function of the DL7400 are as follows:

- Uppercase and lower case alphabet characters and space
- Numbers
- The following symbols: ! " # \$ % & ' () + , - . = @ [] ^ _ ` { } ~

Therefore, note the following points.

- You cannot save folders or files that use characters other than those listed above for the names on the DL7400 storage medium. In addition, these types of files and folders cannot be copied or moved.
- Files and folders that use characters other than those listed above on the DL7400 storage medium do not appear in the file list using WebDAV.
- Files and folders that use characters other than those listed above are excluded from the data capacity calculation. Therefore, the actual used space and the calculated space may differ.

File Information

If a file or folder on the DL7400 storage medium is copied to a local disk on the PC, the date/time of creation of the file or folder is changed to the date/time when the file or folder is copied.

If a file or folder on a local disk on the PC is copied to the DL7400 storage medium, the date/time of creation and date/time of modification of the file or folder are changed to the date/time when the file or folder is copied.

14.1 External Trigger Input, External Clock Input, and Trigger Gate Input



CAUTION

Only input signals that meet the specifications below. Otherwise, undesirable signal such as excessive voltage may damage the DL7400.

External Trigger Input Terminal

This terminal is used when an external signal is used as a trigger source (see section 6.6). This terminal is also used as the external clock input terminal (EXT CLOCK IN) and the trigger gate input terminal (TRIG GATE IN).

Item	Specifications
Connector type	BNC
Maximum input voltage	± 40 V (DC+ACpeak) or 28 Vrms when the frequency is 10 kHz or less
Input frequency bandwidth	DC to 100 MHz
Input impedance	Approx. 1 M Ω , approx. 22 pF
Input range	± 2 V
Trigger sensitivity	0.1 V _{P-P}
Trigger level	± 2 V (resolution is 5 mV)



External Clock Input Terminal

Use this terminal if you wish to operate the DL7400 using an external clock signal (see section 5.11). This terminal is also used as the external trigger input terminal (EXT TRIG IN) and the trigger gate input terminal (TRIG GATE IN).

Item	Specifications
Connector type	BNC
Maximum input voltage	± 40 V (DC+ACpeak) or 28 Vrms when the frequency is 10 kHz or less
Frequency range	40 Hz to 20 MHz (continuous clock only)
Input impedance	Approx. 1 M Ω , approx. 22 pF
Input range	± 2 V
Threshold level	± 2 V (resolution is 5 mV)
Minimum input amplitude	0.1 V _{P-P}
Minimum pulse width	10 ns or more for high and low



Note

The threshold level for the external clock input and the trigger level for the external trigger input are common.

Trigger Gate Input Terminal

The terminal is used when you wish to activate the trigger using an external signal (see section 6.17). This terminal is also used as the external trigger input terminal (EXT TRIG IN) and the external clock input terminal (EXT CLOCK IN).

Item	Specifications
Connector type	BNC
Maximum input voltage	± 40 V (DC+ACpeak) or 28 Vrms when the frequency is 10 kHz or less
Frequency range	DC to 50 MHz
Input impedance	Approx. 1 M Ω , approx. 22 pF
Input range	± 2 V
Minimum input amplitude	0.1 V _{P-P}
Minimum pulse width	10 ns or more for high and low



EXT CLOCK IN
EXT TRIG IN
TRIG GATE IN
 ≤ 40 Vpk 1M Ω

Note

The determination level for the trigger gate input and the trigger level for the external trigger input are common.

14.2 Trigger Output



CAUTION

Never apply external voltage to the TRIG OUT terminal. Doing so can cause damage to the DL7400.

Trigger Output Terminal

A TTL level signal is output when a trigger is activated. The signal level is normally high and goes low when a trigger is activated.

Item	Specifications
Connector type	BNC
Output level	TTL
Output logic	$\overline{1}$ (Negative)
Output delay time	50 ns or less
Output hold time	1 μ s minimum for low level and 100 ns minimum for high level



Circuit Diagram of the Output Section

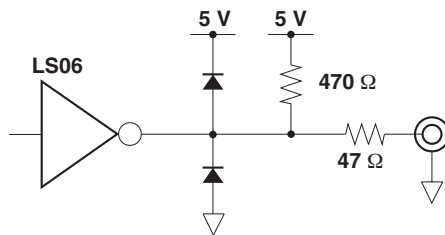

Output Timing

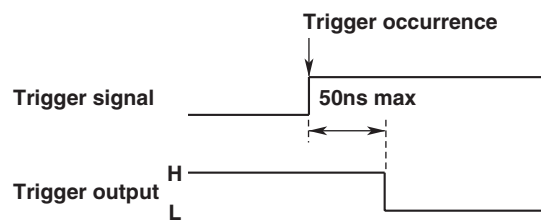

Low Level/High Level Hold Time

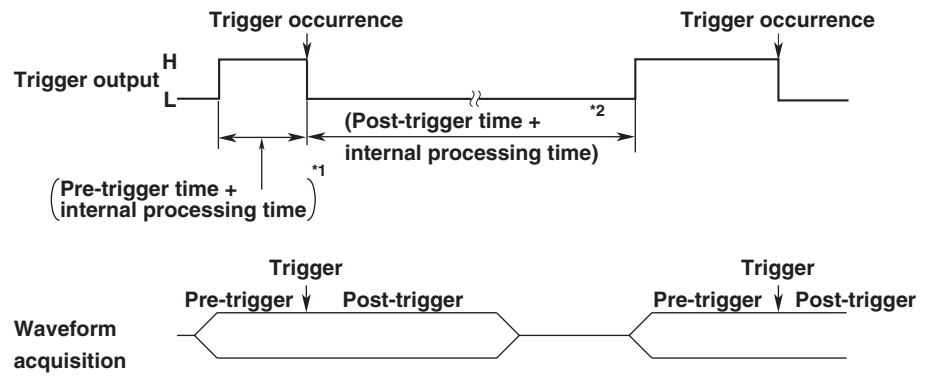

^{*1} HIGH (high level) interval
Indicates the pre-trigger and internal processing time. 100 ns minimum.

^{*2} LOW (low level) interval
Indicates the post-trigger and internal processing time. 1 μs minimum.

14.3 Video Signal Output (VIDEO OUT (VGA))



CAUTION

- Connect the cable after turning OFF the DL7400 and the monitor.
- Do not short the VIDEO OUT (VGA) terminal or apply external voltage to it. Doing so can cause damage to the DL7400.

Video Signal Output Connector

The DL7400 display can be output to a monitor through the RGB output. Connectable monitors are VGA monitors or multi-sync monitors capable of displaying VGA.

Pin No.	Signal Name	Specifications
1	Red	0.7 Vp-p
2	Green	0.7 Vp-p
3	Blue	0.7 Vp-p
4	–	
5	–	
6	GND	
7	GND	
8	GND	
9	–	
10	GND	
11	–	
12	–	
13	Horizontal sync signal	Approx. 31.3 kHz, TTL negative logic
14	Vertical sync signal	Approx. 60 Hz, TTL negative logic
15	–	



VIDEO OUT
(VGA)

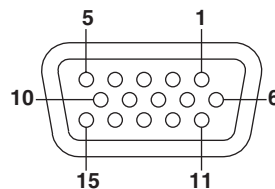

D-Sub 15-pin receptacle

Connecting to the Monitor

1. Turn OFF the DL7400 and the monitor.
2. Connect the DL7400 and the monitor using an analog RGB cable.
3. The screen of the DL7400 appears on the monitor when both the DL7400 and the monitor are turned ON.

Note

- The RGB video signal is constantly output from the VIDEO OUTPUT terminal.
- The monitor screen may flicker if the DL7400 or another instrument is brought close to the monitor.
- The edge of the screen may drop out depending on the monitor type.

15.1 Changing the Message Language and Turning ON/OFF the Click Sound

Procedure

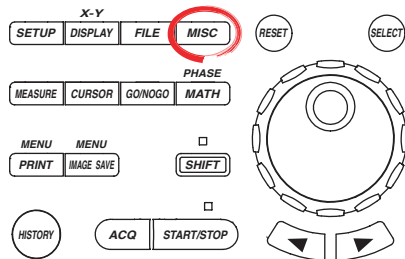

- To exit the menu during operation, press **ESC** located above the soft keys.
- For a description of the operation using a USB keyboard or a USB mouse, see section 4.3.

1. Press **MISC**. The MISC menu appears.
2. Press the **System Config** soft key. The System Config menu appears.

Selecting the Message Language

3. Press the **Message** soft key to select JPN or ENG.

Turning ON/OFF the Click Sound

3. Press the **Click Sound** soft key to select ON or OFF.

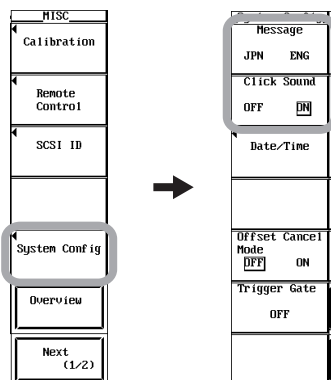

Explanation

Message Language

You can select the language of the messages that appear such as when an error occurs. The messages codes are common to both languages. For details on the messages, see section 16.2.

JPN
Displays Japanese messages.

ENG
Displays English messages.

Turning ON/OFF the Click Sound

You can turn ON/OFF the click sound that is heard when the jog shuttle is turned. The default setting is ON.

ON
Enables click sounds.

OFF
Disable click sounds.

15.2 Changing the USB Keyboard Language and Checking the Connected USB Keyboard

Procedure

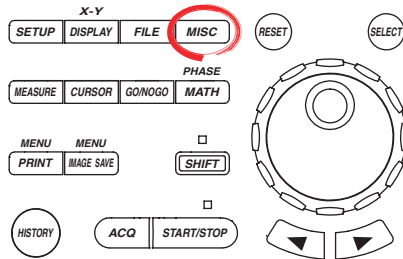

- To exit the menu during operation, press **ESC** located above the soft keys.
- For a description of the operation using a USB keyboard or a USB mouse, see section 4.3.

1. Press **MISC**. The MISC menu appears.
2. Press the **Next (1/2)** soft key. The page 2 menu appears.
3. Press the **USB** soft key.

Setting the Keyboard Language

4. Press the **Keyboard** soft key to select JPN or ENG.

Checking the Connected Keyboard

4. Press the **Device List** soft key. The USB Device List window appears.

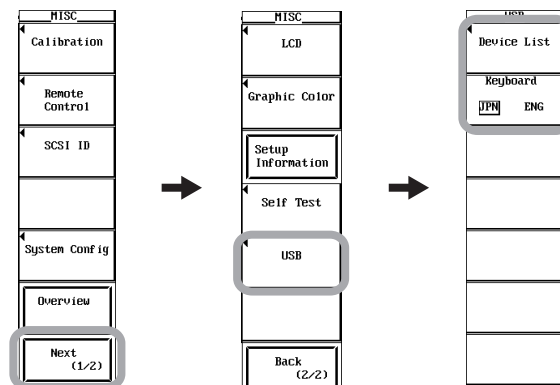

Explanation

USB Keyboard Language

You can select the language of the USB keyboard that is used to enter items such as file names and comments (see section 4.3). Keyboards conforming to USB Human Interface Devices (HID) Class Version 1.1 can be used.

ENG 104 keyboard and 89 keyboard

JPN 109 keyboard and 89 keyboard

The character that is entered through each key of the USB keyboard varies depending on the keyboard type. For details, see appendix 6.

Checking the Connected Keyboard

The USB devices that are connected can be listed.

Note

For USB keyboards that have been tested for compatibility, contact your nearest YOKOGAWA dealer.

15.3 Measuring the Offset Voltage and Applying the Offset Voltage to the Computed Results

Procedure

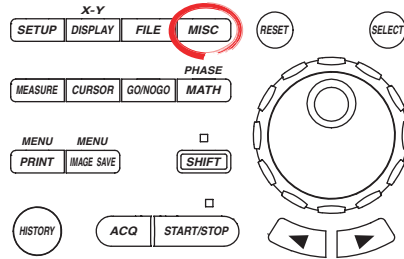

- To exit the menu during operation, press **ESC** located above the soft keys.
- For a description of the operation using a USB keyboard or a USB mouse, see section 4.3.

1. Press **MISC**. The MISC menu appears.
2. Press the **System Config** soft key. The System Config menu appears.
3. Press the **Offset Cancel Mode** soft key to select ON or OFF.

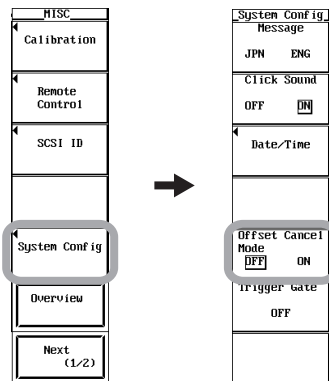

Explanation

The offset value that is specified for each channel can be subtracted from the input signal and used for computation and automated measurement. The default setting is OFF.

OFF

The offset value is not applied to computations and the results of automated measurements. Waveform is observed without subtracting the offset voltage (DC voltage) from the input signal. The vertical position of the screen corresponds to the offset voltage.

ON

The offset value is applied to computations and the results of automated measurements. The offset value specified for each channel can be used to subtract unneeded offset voltage (DC voltage) from the input signal for waveform observation. The vertical position is set to 0 V.

Note

The ON/OFF setting of the offset voltage applies to all channels. To turn ON/OFF the offset voltage for each channel separately, use the linear scaling function.

15.4 Setting the Screen Color and Intensity

Procedure

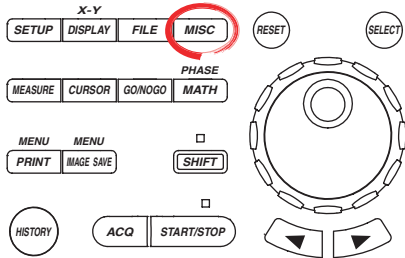

- To exit the menu during operation, press **ESC** located above the soft keys.
- In the procedural explanation below, the term *jog shuttle* & **SELECT** refers to the operation of selecting/setting items and entering values using the *jog shuttle* and **SELECT** and **RESET** keys. For details on this operation, see sections 4.1 or 4.2.
- For a description of the operation using a USB keyboard or a USB mouse, see section 4.3.

1. Press **MISC**. The MISC menu appears.
2. Press the **Next (1/2)** soft key The page 2 menu appears.
3. Press the **Graphic Color** soft key. The Graphic Color menu appears.
4. Press the **Mode** soft key. The Mode menu appears.

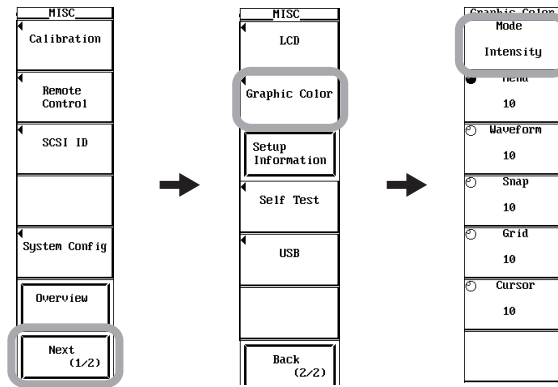

Setting the Display Color

5. Press the **RGB** soft key. The RGB menu appears.
6. Press the **Menu** soft key. The Menu dialog box opens.
7. Use *jog shuttle* & **SELECT** to set the menu screen color.
8. Press **ESC**. The Menu dialog box closes.
9. Likewise, set the colors for Waveform and Other.

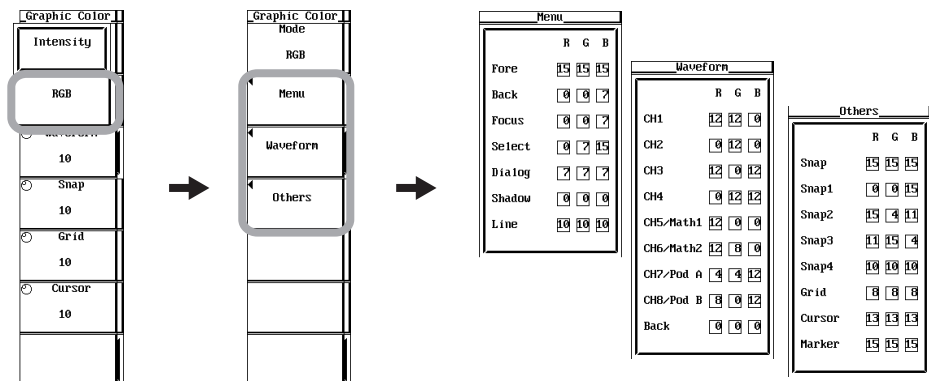

Setting the Intensity

5. Press the **Intensity** soft key. The Intensity menu appears.
6. Press the **Menu** soft key.
7. Turn the **jog shuttle** to set the intensity of the menu screen.
8. Likewise, set the intensity of Waveform, Snap, Grid, and Cursor.

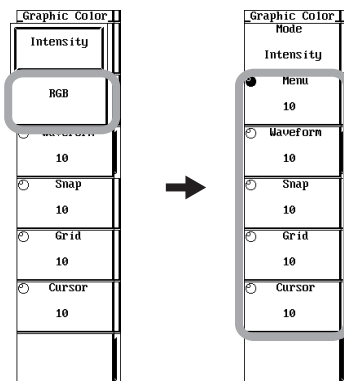

Explanation

Display Color

You can set the screen color using a ratio of red (R), green (G), and blue (B) for each item. The selectable range is 0 to 15 levels, and the resolution is 1 level.

Item	Target
Menu	
Fore	Selected menu item
Back	Background color
Focus	Selection cursor
Select	Selected menu
Dialog	Dialog box
Shadow	Background color of the selected menu
Line	Menu screen lines
Waveform	
CH1 to Pod B	Waveform color
Back	Background color of the waveform display area
Other	
Snap	Snapshot waveforms
Snap1 to 4	Loaded snapshot waveforms
Grid	Graticule
Cursor	Cursor
Maker	Markers

Intensity

You can set the intensity in the range of 1 to 15 levels for each item. The selectable range is 1 to 15 levels, and the resolution is 1 level.

Item	Target
Menu	Menu
Waveform	Waveforms
Snap	Snapshot waveforms
Grid	Graticule
Cursor	Cursor

15.5 Turning OFF the Backlight and Setting the Brightness of the Backlight

Procedure

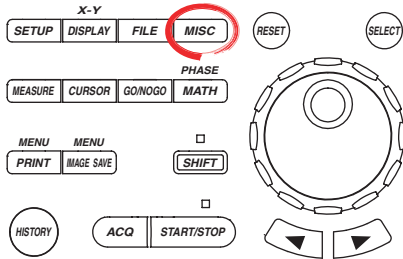

- To exit the menu during operation, press **ESC** located above the soft keys.
- For a description of the operation using a USB keyboard or a USB mouse, see section 4.3.

1. Press **MISC**. The MISC menu appears.
2. Press the **Next (1/2)** soft key. The page 2 menu appears.
3. Press the **LCD** soft key. The LDC menu is displayed.

Setting Auto Off

4. Press the **Auto Off** soft key to select ON or OFF.
If you set Auto OFF to ON, the Auto OFF Time menu appears. Proceed to step 5.
5. Press the **Auto OFF Time** soft key.
6. Turn the **jog shuttle** to set the time when the backlight will automatically turn OFF.

Setting the Backlight Brightness

4. Press the **Brightness** soft key.
5. Turn the **jog shuttle** to set the backlight brightness.

Turning OFF the Backlight

4. Press the **LCD OFF Exec** soft key. The backlight turns OFF.
Pressing any panel key turns the backlight ON allowing the screen to be viewed.

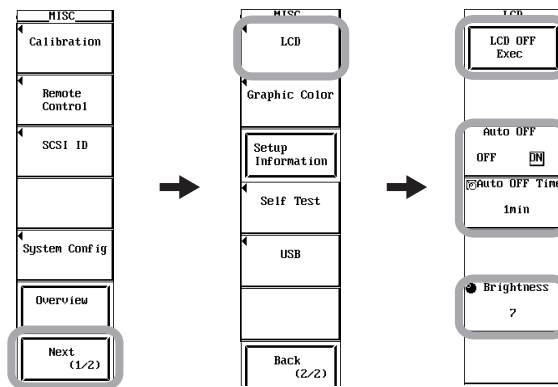

Explanation

Turning ON/OFF the Backlight

You can turn ON/OFF the LCD backlight.

- Pressing the LCD OFF EXEC soft key turns OFF the backlight.
- Pressing any panel key turns the backlight ON allowing the screen to be viewed.

Backlight Auto OFF

The backlight automatically turns OFF if there is no key operation for the specified time. The selectable range is 1 to 60 min, and the resolution is 1 min.

Backlight Brightness

You can change the brightness of the backlight. Dimming the backlight brightness or leaving the backlight turned OFF prolongs its life. The selectable range is 0 to 7 levels, and the resolution is 1 level.

16.1 Troubleshooting

- If a message is displayed on the screen, read the following pages.
- If servicing is necessary, or if the instrument is not operating correctly after performing the corrective actions below, contact your nearest YOKOGAWA dealer.

Description	Probable Cause	Corrective Action	Reference Section
The power cannot be turned ON.	Using a power supply outside the ratings.	Use a correct power supply.	3.3
Nothing is displayed.	The backlight is turned OFF.	Press any key.	15.5
	The screen colors are not appropriate.	Set the screen color.	15.4
The display is odd.	The system is not operating properly.	Power-cycle the DL7400.	3.3
The waveform display does not update.	Waveform data was loaded from an external storage medium.	Unload the loaded waveform data.	12.8
Keys do not work.	The DL7400 is in remote mode.	Press SHIFT + CLEAR TRACE to enable local mode.	–
	Other causes.	Perform a key test. If the test fails, servicing is required.	16.3
Trigger does not activate.	The trigger gate is enabled.	Turn OFF the trigger gate.	6.17
	The trigger settings are not appropriate.	Set the trigger conditions correctly.	Chapter 6
Measured values are not correct.	Insufficient warm-up.	Warm up the DL7400 for 30 minutes after turning on the power.	–
	Not calibrated.	Execute calibration.	4.6
	The probe's phase has not been corrected.	Perform phase correction correctly.	3.5
	The probe attenuation is not correct.	Set an appropriate value.	5.5
	An offset voltage is added.	Set the offset voltage to 0 V.	5.6
	Other causes.	Execute calibration. If the measured value is still odd, servicing is required.	4.6
Cannot output to the built-in printer.	The printer head is damaged or worn out.	Servicing required.	–
Cannot save to the specified medium.	The medium is not formatted.	Format the medium.	12.6
	The medium is write-protected.	Release the medium's write-protect.	–
	No more free space on the medium.	Delete unneeded files or use another storage medium.	12.6, 12.14
Cannot change settings or control the operation of the DL7400 via the communication interface.	The address of the DL7400 used by the program is different from the specified address.	Match the address used in the program to the address of the DL7400.	Communication Interface User's Manual (IM 701450-17E, CD-ROM)
	The interface is not used in a way that conforms to the electrical or mechanical specifications.	Use it in a way that conforms to the specifications.	

16.2 Messages and Corrective Actions

Messages

A message (or an error message) may appear during operation. This section describes the meanings of the messages and their corrective actions. The messages can be displayed either in English or Japanese (see section 15.1). If the corrective action requires servicing, contact your nearest YOKOGAWA dealer.

In addition to the messages listed below, there are communication error messages. These messages are described in the *Communication Interface User's Manual* (IM 701450-17E, CD-ROM).

Status Messages

Code	Message	Corrective Action	Sections
0	Aborted hard copy.	–	11.2
1	Aborted file operation.	–	Chapter 12
2	Completed data store.	–	12.1
3	Completed data recall.	–	12.1
4	Completed GO/NO-GO.	–	10.9, 10.10
10	Set to remote mode by communication commands.	Press SHIFT + CLEAR TRACE to enable local mode.	–
11	Local lockout by communication commands.	To operate the keys, release lockout using communication commands.	–
13	All settings will be initialized. Power up with the RESET key depressed.	–	4.4
21	Completed action-on-trigger.	–	6.16
22	Executed unload.	–	12.8, 12.9
23	Released the Preview mode.	–	11.2
24	Some of the channels are set to 50 ohm DC input. To keep the settings, press the SELECT key. Pressing any other key will change the settings to 1 Mohm DC input.	–	5.4
25	Aborted the search.	–	10.2 to 10.4
26	Executed the search, but no record was found that matched the conditions.	–	10.2 to 10.4
27	Executed the search, but no pattern was found that matched the conditions.	–	10.2 to 10.4
28	Pattern contains points that are between Thr Lower and Thr Upper.	–	10.4
29	MATH will be performed on all records. Abort the operation by setting the history Display Mode to One.	–	–
30	Aborted the recalculation of the MATH.	–	–
31	The logic option is not installed on this model.	–	Page ii
32	Aborted statistical measurement processing.	–	10.7
36	Key invalid for this model.	–	–
37	Aborted the analysis.	–	–
38	Data not detected. Execute again after changing the settings or reacquiring the waveform.	–	10.11

Errors in Execution (600 to 799)

Code	Message	Corrective Action	Sections
601	Invalid file name or SCSI ID.	Check the file name or SCSI ID number.	12.4, 12.6 to 12.10
602, 603	No SCSI device or no storage media inserted.	Check the SCSI device connection, SCSI ID number, and the presence of a storage medium.	12.3, 12.4
604	Storage media failure.	Check the storage medium.	–
605	File not found.	Check the file name and storage medium	Chapter 12
606	Storage media is protected.	Turn OFF the write-protect switch on the storage medium.	–
607	Storage media failure.	Check the storage medium.	–
608-610	Invalid file name or SCSI ID.	Check the file name or SCSI ID number.	12.4, 12.6 to 12.10
611, 612	Storage media full.	Delete unneeded files or use another storage medium.	12.6, 12.14
613	Cannot delete a directory if there are files in the directory.	Delete all the files in the directory to be deleted.	12.14
614	File is protected.	Change the attribute to R/W.	12.14
615	Physical format error.	Reformat the storage medium. If the same error occurs, the storage medium cannot be formatted using the DL7400.	12.6
616-620	File system failure.	Check using a different storage medium. If it still fails, servicing required.	–
621	File is damaged.	Check the file.	–
622-641 656-663	File system failure.	Check using a different storage medium. If it still fails, servicing required.	–
642	No storage media exists in SCSI device.	Check the presence of the storage medium of the SCSI device.	–
646-653	Storage media failure.	Check the storage medium.	–
654	Storage media failure.	Check the format type of the floppy disk.	12.6
665	Cannot load this file format.	Files saved on other models (such as YOKOGAWA DL/AG Series) cannot be loaded.	–
666	File is now being accessed. Wait a moment.	Execute after the access is finished.	–
667	Cannot be executed while data acquisition is in progress.	Press the START/STOP key to stop the waveform acquisition first.	7.1
668	Cannot find ".HDR" file.	Check the file.	12.8
669	Cannot load the specified file on this ROM version or this model.	Upgrade the firmware.	–
671	Save data not found.	Check the existence of the data to be saved.	–
673	SCSI controller failure.	Servicing required.	–
676	Unknown file format.	Check whether the data is in a format that the DL7400 can handle. Change the extension	12.7 to 12.13
677	P-P compression cannot be used to save FFT waveforms.	Turn OFF the P-P compression and save the data.	12.8
679	Data that have been P-P compressed and saved cannot be loaded.	–	–
680	Illegal printer head position.	Move the release arm to the HOLD position.	11.1
681	Paper empty.	Install the roll paper.	11.1
682	Printer overheated.	Turn OFF the power immediately. Servicing required.	–
683	Printer overheated.	Turn OFF the power immediately. Servicing required.	–
684	Printer is not installed.	Check the specifications to see if your model has the optional printer.	Page ii
685	Printer time out.	Servicing required.	–

16.2 Messages and Corrective Actions

Code	Message	Corrective Action	Sections
691	The printer has malfunctioned.	Servicing required.	–
692	Printer error. Turn the power of the printer from OFF to ON.	–	–
693	Printer offline.	–	–
694	Out of paper.	–	–
695	Printer is in use.	–	–
696	Cannot detect printer. Turn ON the printer. Check connectors.	–	–
697	No files supporting the thumbnail display window.	–	12.13
701	Cannot be executed while data acquisition is	Press the START/STOP key to stop the waveform acquisition first.	7.1
703	There is no data to be undone.	Undo is not possible because the data immediately before the initialization or auto setup does not exist.	4.4, 4.5
704	Cannot be executed while data acquisition is	Press the START/STOP key to stop the waveform acquisition first.	7.1
705	This data cannot be backed up.	–	–
706	There is no data to be recalled.	–	12.1
707	Cannot start during data output.	Wait until the output is complete.	Chapter 11
711	Cannot access file while hard-copying.	Wait until the output is complete.	11.2
712	Cannot compress this screen image. Turn off the compression switch.	Turn OFF the compression setting.	12.12
713	Calibration failure. Disconnect the input and execute again. If it fails again, servicing is required.	Servicing required.	–
726	Cannot start when loading waveform data that has been saved in history All mode.	Execute unload.	12.8
727	Insufficient output data. Increase Mag or widen the Time Range interval.	Increase Mag or widen the Time Range interval.	11.2
728	Hard copying. Abort or wait until it is complete.	Press COPY again to abort.	11.2
729	Cannot perform calibration while waveform data is loaded.	Unload the loaded waveform using the FILE menu.	12.8
730	Pattern is not specified.	Set at least one of the search pattern to a value other than x.	10.4
731	Cannot start when waveform data that has been acquired in the linear average mode is loaded.	Unload the loaded waveform using the FILE menu.	12.8
732	Cannot be executed while computation is in progress.	Turn OFF Display of the MATH menu and abort the computation.	9.1
733	Failed to measure statistics. The target waveform data exists or the measured waveform data may not exist. If Cycle Statistics is specified, the instrument may be configured in a way that fails to detect the cycle.	Check to see that waveform data to be measured exists and that there is at least one cycle of waveform within the measurement range.	10.7
734	Cannot be executed during the interleave mode. Change the Clock CH.	–	10.11
735	Cannot store because the data is locked. Release the lock through Store Detail.	Release the lock through Store Detail.	12.1
736	The File item is inappropriate. Select Waveform, Snap, or Measure.	Select Waveform, Snap, or Measure.	–
737	Executing file Load, Save, or Format. Abort or wait until it is complete.	–	–
738	Hard copying or saving image. Abort or wait until it is complete.	–	–

Code	Message	Corrective Action	Sections
739	Analyzed data does not exist. Execute the analysis.	Execute analysis.	10.11
750	Cannot connect to the server.	Check network configuration and connection.	Chapter 13
751	Not yet connected to the ftp server.	Check network configuration and connection.	Chapter 13
752	This ftp function is not supported.	–	Chapter 13
753	FTP Error: Pwd	Check network configuration and connection.	Chapter 13
754	FTP Error: Cwd	Check network configuration and connection.	Chapter 13
755	FTP Error: Rm	Check network configuration and connection.	Chapter 13
756	FTP Error: List	Check network configuration and connection.	Chapter 13
757	FTP Error: Mkdir	Check network configuration and connection.	Chapter 13
758	FTP Error: Rmdir	Check network configuration and connection.	Chapter 13
759	FTP Error: Get	Check network configuration and connection.	Chapter 13
760	FTP Error: Put	Check network configuration and connection.	Chapter 13
761	FTP Error: GetData	Check network configuration and connection.	Chapter 13
762	FTP Error: PutData	Check network configuration and connection and disk space.	Chapter 13
763	FTP Error: AppendData	Check network configuration and connection and disk space.	Chapter 13
764	FTP Error: Client Handle	Check network configuration and connection.	Chapter 13
765	FTP Error: Others	Check network configuration and connection.	Chapter 13
770	Failed to acquire time from SNTP server. Confirm the network settings and connection.	Check network configuration and connection.	Chapter 13
785	Cannot send data to a network printer.	Check network configuration and connection.	Chapter 13
786	Cannot send the e-mail message.	Check network configuration and connection.	Chapter 13
797	Connecting to a NetDrive. Wait until connection has been established.	–	Chapter 13

Errors in Setting (800 to 899)

Code	Message	Corrective Action	Sections
800	Illegal date/time.	Set them correctly.	3.7
801	Illegal file name.	Illegal character exists, or the file name is restricted by MS-DOS. Enter a different file name.	4.2
804	Cannot change this parameter while data acquisition is in progress.	Press the START/STOP to stop the waveform acquisition first.	7.1
806	GO/NO-GO is in execution Please press the Abort key.	Abort GO/NO-GO.	10.9, 10.10
814	Duplicated label.	Set a different label.	8.9
819	Cannot change when Channel Display is OFF or Math settings are invalid.	Turn ON the channel display or set the computation.	5.1, 9.1
821	Cannot change when ExtClock is active.	Set the time base to Internal.	5.11
827	Illegal math expression. Input a correct computing equation.	–	9.9
829	Cannot change when Logic Mode is OFF or all bits of Logic Display are OFF.	–	5.10
830	Cannot set anything other than Low Pass for a Gaussian filter. Change the Filter Type to another filter besides Gaussian.	–	9.9
836	Cannot change settings during action-on-trigger.	Abort abort-on-trigger.	6.16, 7.1
840	Cannot set the acquisition mode to Average when the trigger mode is set to Single or Single(N).	Change the acquisition mode or change the trigger mode.	6.1, 7.5

16.2 Messages and Corrective Actions

Code	Message	Corrective Action	Sections
841	It is not possible to make a setting that will result in the repetitive mode when the trigger mode is set to Single(N).	Set the trigger mode to a mode other than Single (N).	6.1
842	Cannot specify A→B(N) and A Delay B when the trigger gate is active.	Turn OFF the trigger gate.	6.17
843	Cannot set the trigger mode to Single or Single(N) when the acquisition mode is Average.	Change the acquisition mode or change the trigger mode.	6.1, 7.5
846	Cannot set the trigger mode to Single(N) during repetitive sampling mode.	Turn OFF the repetitive mode, lower T/div, or shorten the record length.	5.12, 7.4
847	Cannot set this parameter during repetitive sampling mode.	Turn OFF the repetitive mode, lower T/div, or shorten the record length.	5.12, 7.4
848	Not possible during the interleave mode.	Turn OFF interleave mode.	7.3
850	Not possible in the current record length.	Change the record length.	7.2
851	Cannot carry out computation at the current record length.	Change the record length.	7.2
852	The operation is not possible when waveforms are loaded. Unload the loaded files from the FILE menu.	Execute unload.	12.8
853	Setting or executing is not possible during the search operation.	Abort the search.	10.2 to 10.4
854	Search pattern does not exist. Execute the search.	Change the search conditions and search again.	10.4
855	Settings cannot be changed or executed during the history search operation.	Abort the search.	10.2, 10.3
856	The record cannot be selected.	Check the record number using Show Map.	10.2, 10.3
857	History record does not exist.	History record is not possible in average mode, repetitive sampling mode, and roll mode.	7.4, 7.5
858	Settings or executing is not possible during FFT recalculation. Abort the operation by setting the history Display Mode to One.	Set Display Mode on the HISTORY menu to One.	10.1
860	Cannot be configured or executed while updating the history all display. Aborted when history display mode is set to One.	Set Display Mode on the HISTORY menu to One.	10.1
861	Cannot output color in this format.	Turn OFF the color.	11.3
862	Zones cannot be edited in the following cases: • When the main window is not displayed. • When the target waveform is not displayed.	Display the main window and the target waveform.	10.9
863	The zone waveform does not exist.	Create the zone waveform.	10.9
864	The zone is being edited. To perform other operations, select Quit to exit zone editing.	Select Quit to exit zone editing.	10.9
865	Zones determination is not possible in the following cases: • When the main window is not displayed. • When the target waveform is not displayed. • When the zone waveform does not exist.	Display the main window and the target window and create the zone waveform.	10.9
868	Processing statistics. To perform other operations, abort the statistical processing.	Abort statistical processing.	10.7
870	Cannot be specified. Invalid byte or bit.	Increase the data length.	10.11
871	Cannot be set when CS channels are not specified.	Specify the CS channels.	10.11

Error in System Operation (900 to 908, 912 to 914)

Code	Message	Corrective Action	Sections
901	Failed to backup setup data. Will initialize.	Servicing required. The backup battery may be flat.	–
906	Fan stopped; Turn off the power immediately.	Turn OFF the power immediately. Servicing required.	–
907	Backup battery is flat.	Servicing is required for battery replacement.	–
912	Fatal error in the communication driver.	Servicing required.	–

Note

If servicing is required, initialize the instrument once for confirmation.

16.3 Performing a Self-Test

Procedure

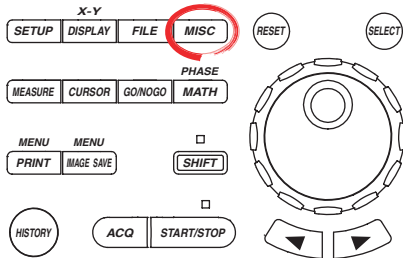

- To exit the menu during operation, press **ESC** located above the soft keys.
- For a description of the operation using a USB keyboard or a USB mouse, see section 4.3.

Displaying the Self Test Menu

1. Press **MISC**. The MISC menu appears.
2. Press the **Next (1/2)** soft key. The page 2 menu appears.
3. Press the **Self Test** soft key. The Self Test menu appears.

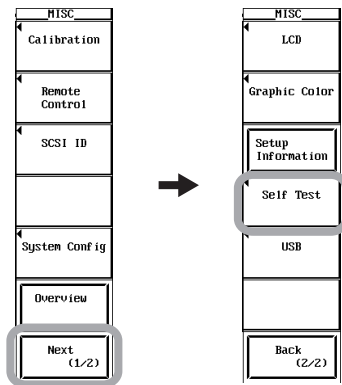

Testing the Memory, Floppy Disk (or Zip) Drive, SCSI, Printer, Accuracy, and PC Card Drive

4. Press the **Test Item** soft key. The Test Item menu appears.
5. Press the **Memory**, **FDD (or Zip)**¹, **SCSI**², **Printer**, **Accuracy**, or **PC CARD** soft key to select the test item.
 - 1 Varies on the specifications of the model.
 - 2 Selectable if the SCSI option is installed.
6. Press the **Test Exec** soft key. The Test of the selected item is executed.

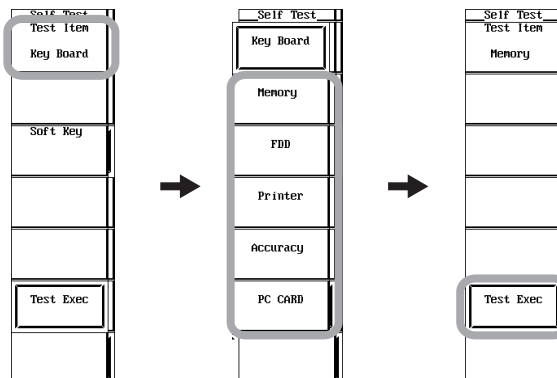

Executing the Key Test

4. Press the **Test Item** soft key. The Test Item menu appears.
5. Press the **Key Board** soft key. The Key Board menu appears.
6. Press the **Test Exec** soft key. The Key Board Test window appears.
7. When you press a panel key, the character of the same key name is highlighted in the Key Board Test window.

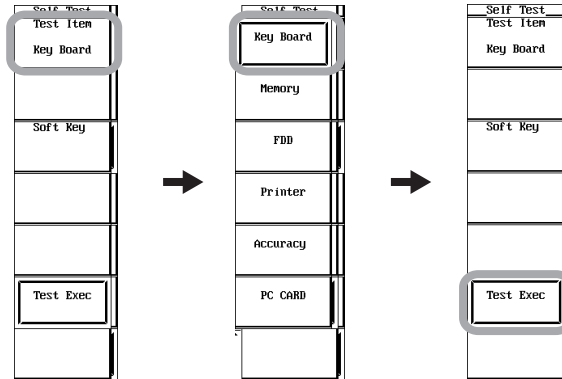

8. Press all panel keys or press **ESC** twice. The key test is terminated.

Testing the Soft Keys

9. Press the **Soft Key** soft key. A keyboard used to enter values and strings appears.
10. Use **jog shuttle & SELECT** or soft keys to check that all the characters on the keyboard can be entered correctly.
11. Press **ESC**. The keyboard used to enter values and strings clears.

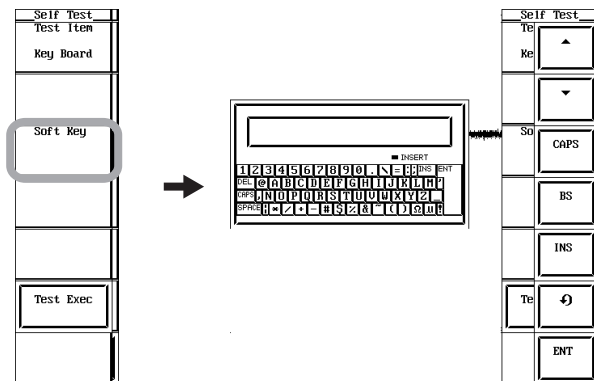

Note

- When performing a self test on the floppy disk or Zip drive, insert a floppy disk or Zip disk into the drive before executing the test.
- Note the following points when performing a self test on the SCSI (optional).
 - Perform the self test without using partitions.
 - Set the SCSI ID of the SCSI device to be connected to 5.
- Perform the PC card self-test in a condition in which partitions are not used.

Explanation

Memory Test

Tests whether the internal ROM and the built-in backup lithium battery is operating correctly. If "Pass" is displayed, it is operating correctly. If "Failed" is displayed, contact your nearest YOKOGAWA dealer.

Floppy Disk (or Zip)* Drive Test

Tests whether the floppy disk (or Zip) drive is operating properly. If "Failed" is displayed after the test, contact your nearest YOKOGAWA dealer.

* Included on certain models only.

SCSI test*

Tests whether SCSI is operating properly. If "Failed" is displayed after the test, contact your nearest YOKOGAWA dealer.

* Selectable on models with the SCSI option.

Printer Test

Tests whether the built-in printer is operating properly. If the tint is printed correctly, the operation is normal. If printing is not correct, contact your nearest YOKOGAWA dealer.

Accuracy Test

Tests the accuracy of the A/D converter. If "Failed" is displayed, contact your nearest YOKOGAWA dealer.

PC Card Test

Tests whether the PC card is operating properly. If "Failed" is displayed after the test, contact your nearest YOKOGAWA dealer.

Key Test

Tests whether the front panel keys are operating properly. If the name of the key being pressed appears highlighted, the key is operating correctly. If it does not, contact your nearest YOKOGAWA dealer.

Soft Key Test

Tests whether the soft keys are operating properly. If the characters on the keyboard used to enter values and strings are entered correctly, the soft keys are operating correctly. If not, contact your nearest YOKOGAWA dealer.

16.4 Checking the System Conditions (Overview)

Procedure

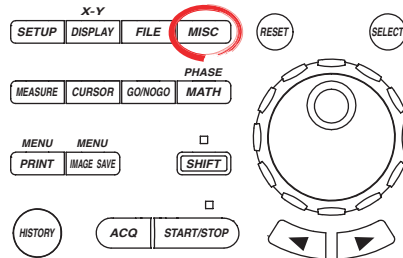

- To exit the menu during operation, press **ESC** located above the soft keys.
- For a description of the operation using a USB keyboard or a USB mouse, see section 4.3.

1. Press **MISC**. The MISC menu appears.
2. Press the **Overview** soft key. The Overview window opens.
Pressing a panel key other than the Overview soft key clears the Overview window.

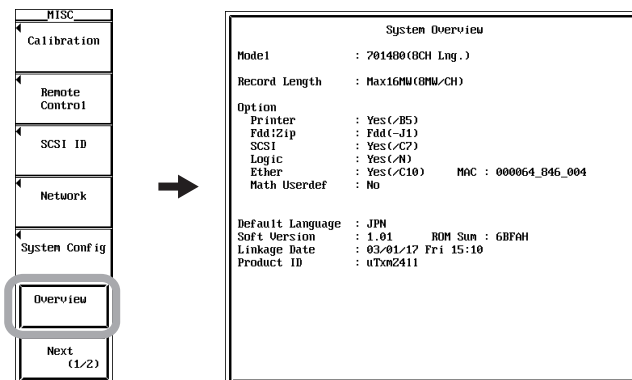

Explanation

You can check the firmware version, model, and the presence or absence of options on a screen similar to the one shown above.

16.5 Recommended Replacement Parts

The three-year warranty applies only to the main unit of the instrument (starting from the day of delivery) and does not cover any other items nor expendable items (items which wear out). Contact your nearest YOKOGAWA dealer for replacement parts.

Parts Name	Replacement Period
Built-in printer	Under normal usage, 120 rolls of paper (part no.: B9850NX)
LCD backlight	Approx. 25000 hours under normal use

The following items are expendable items. It is recommended that the parts be replaced according to the period indicated below. Contact your nearest YOKOGAWA dealer for replacement parts.

Parts Name	Recommended Replacement Period
Cooling fan	3 years
Backup battery (lithium battery)	5 years

17.1 Input Section

Item	Specifications
Number of input channels	DL7440 (4-channel model, models 7071450 and 701460): 4 (CH1 to CH4) DL7480 (8-channel model, models 7071470 and 701480): 8 (CH1 to CH8)
Input coupling	AC 1M Ω , DC 1M Ω , DC 50 Ω , and GND
Input connector	BNC connector
Input impedance	1 M Ω ±1.0%, approx. 20 pF 50 Ω ±1.0% (VSWR 1.4 or less (DC to 500 MHz))
Voltage-axis sensitivity setting	For 1M Ω input: 2 mV/div to 10 V/div (1-2-5 steps) For 50 Ω input: 2 mV/div to 1 V/div (1-2-5 steps)
Maximum input voltage ¹	For 1 M Ω input (at a frequency of 1 kHz or less): 400 V (DC+ACpeak) (282 Vrms CAT II) For 50 Ω input: 5 Vrms and 10 Vpeak (not to exceed either of the two values)
Maximum DC offset setting range (When the probe attenuation is set to 1:1)	2 mV/div to 50 mV/div: ±1 V 100 mV/div to 500 mV/div: ±10 V 1 V/div to 10 V/div: ±100 V
Vertical (voltage) axis accuracy DC accuracy ² :	±(1.5% of 8 div + offset voltage axis accuracy)
Offset voltage axis accuracy ²	2 mV/div to 50 mV/div: ±(1% of the setting + 0.2 mV) 100 mV/div to 500 mV/div: ±(1% of the setting + 2 mV) 1 V/div to 10 V/div: ±(1% of the setting + 20 mV)
Frequency characteristics ^{2,3} (-3 dB point when a sine wave of amplitude ±4 divisions is input)	For 50 Ω input 1 V/div to 10 mV/div: DC to 500 MHz 5 mV/div to 2 mV/div: DC to 400 MHz For 1 M Ω input (when using the 700988 passive probe, indicates the frequency of the input signal at the probe tip. The value inside the brackets is the frequency when using the 701941 miniature passive probe.) 10 V/div to 10 mV/div: DC to 400 MHz [DC to 500 MHz] 5 mV/div to 2 mV/div: DC to 300 MHz [DC to 400 MHz]
Lower -3 dB point when AC coupled	10 Hz or less (1 Hz or less when using the 10:1 probe provided)
Skew between channels (When using the same settings)	1 ns or less
Residual noise level ⁴	±1.25 mV or ±0.15 div, whichever is greater (typical value ⁵)
Isolation between channels (Same voltage sensitivity)	At 500 MHz: -34 dB (typical value ⁵)
A/D conversion resolution	8 bits (24 LSB/div)
Probe attenuation setting	1:1, 10:1, 100:1, 1000:1, 10A:1V ⁶ , and 100A:1V ⁶
Bandwidth limit	Turn ON/OFF the 100-MHz or 20-MHz bandwidth limit for each channel.
Maximum sample rate	Realtime sampling mode When interleave mode is ON: 2 GS/s When interleave mode is OFF: 1 GS/s Repetitive sampling mode: 100 GS/s
Maximum record length	4 MW memory model (701450 and 701470) When interleave mode is ON: 4 MW/CH When interleave mode is OFF: 2 MW/CH 16 MW memory model (701460 and 701480) When interleave mode is ON: 16 MW/CH When interleave mode is OFF: 8 MW/CH

- 1 When using the probe, be sure that the maximum input voltage of the DL7400 and the maximum input voltage of the probe are not exceeded.
- 2 Value measured under standard operating conditions (see section 17.12) after warm-up and after calibration with the time base set to internal clock.
- 3 Value in the case of a repetitive phenomenon. The frequency bandwidth of a single-shot phenomenon is the smaller of the two values, DC to sampling frequency/2.5 and the frequency bandwidth of a repetitive phenomenon.
- 4 When the input section is shorted, the record length set to 10 kW, the acquisition mode set to normal mode, the accumulation set to OFF, and the probe attenuation set to 1:1.
- 5 Typical value represents a typical or average value. It is not strictly warranted.
- 6 Automatically set to the optimum values for the current probe (700937, 701930, 701931, 701932, or 701933 sold separately).

17.2 Logic Input Section (Optional)

Item	Specifications
Probes that can be used	701980 ¹ /701981 (8-bit input)
Maximum toggle frequency ²	When using the 701980: 100 MHz, when using the 701981: 250 MHz
Number of inputs	16 (when two logic probes are used)
Maximum input voltage	±40 V (DC+ACpeak) or 28 Vrms when the frequency is 1 kHz or less.
Input range	±10 V
Maximum sample rate	When interleave mode is ON: 2 GS/s When interleave mode is OFF: 1 GS/s
Threshold level	When using the 701980: ±40 V (resolution: 0.1 V) When using the 701981: ±10 V (resolution: 0.1 V)
Threshold accuracy ²	±(0.1 V + 3% of the setting)
Minimum input voltage ²	500 mV _{P-P}
Input impedance	When using the 701980: Approx 1 MΩ/approx. 10 pF When using the 701981: Approx. 10 kΩ, approx. 9 pF
Preset threshold levels	CMOS (5 V): 2.5 V, CMOS (3.3 V): 1.6 V, and ECL: -1.3 V

1 The 701980 can be used only when the firmware version of the DL7400 is 1.30 or later.

2 Under standard operating conditions (see section 17.12) after the warm-up.

17.3 Trigger Section

Item	Specifications
Trigger mode	Auto, auto-level, normal, single, and single(N)
Trigger source	CH1 to CH8/4 ¹ (signal input from each input terminal), LINE (commercial power supply signal that is connected), EXT (signal input from the EXT TRIG IN terminal)
Trigger coupling	CH1 to CH8/4 ¹ : DC/AC EXT: DC
HF rejection	Select the bandwidth limit with respect to the trigger source (OFF, DC to approx. 15 kHz, or DC to approx. 20 MHz) for each channel (CH1 to CH8/4 ¹)
Trigger hysteresis	Select high or low for the trigger level hysteresis width for each channel (CH1 to CH8/4 ¹)
Trigger level range	CH1 to CH8/4 ¹ : ±4 divisions from the screen center (resolution of 0.01 divisions) EXT: ±2 V (resolution is 5 mV)
Trigger level accuracy	CH1 to CH8/4 ^{1, 2} : ±(1 division + 10% of the trigger level) EXT ³ : ±(50 mV + 10% of the trigger level)
Probe attenuation setting for external trigger	1:1 or 10:1
Trigger sensitivity ³	CH1 to CH8/4 ¹ : 1 div _{P-P} at DC to 500 MHz EXT: 100 mV _{P-P} at DC to 100 MHz
Trigger position	Can be set in 1% increments of the display record length.
Trigger delay range	0 to 4 s
Hold off time range	80 ns to 10 s
Trigger slope	Rising, falling, rising and falling (for edge trigger)

Item	Specifications
Trigger type	<p>Edge: Activate the trigger on the edge of a single trigger source.</p> <p>A->B(N): Trigger occurs nth time condition B becomes true after condition A becomes true. Count: 1 to 10⁸ Condition A: Enter/Exit Condition B: Enter/Exit</p> <p>A Delay B: Trigger occurs first time condition B becomes true after specified delay following condition A true. Specified time: 3 ns to 5 s Condition A: Enter/Exit Condition B: Enter/Exit</p> <p>OR: Trigger occurs on the OR logic of the trigger conditions set to multiple trigger sources. Trigger condition is edge or window. Rise (IN), Fall (Out), or Don't Care can be set to each channel CH1 to CH8/4¹.</p> <p>Pattern: Trigger occurs on the edge of the clock channel with respect to the True/False condition of the parallel pattern set to multiple trigger sources. If the clock channel is set to Don't Care, trigger occurs on the Enter or Exit condition of the True/False condition of the parallel pattern. Parallel pattern is the AND of the channels.</p> <p>Width: Trigger occurs on the True/False width of the parallel pattern of multiple trigger sources. Parallel pattern is the AND of the statuses of the channels or the AND of the window conditions of the channels.</p> <p>Pulse<Time: Trigger occurs when the width described above is smaller than Time.</p> <p>Pulse>Time: Trigger occurs when the width described above is greater than Time.</p> <p>T1<Pulse<T2: Trigger occurs when the width described above is greater than T1 and smaller than T2.</p> <p>Time Out: Trigger occurs when the width described exceeds Time. Specified time: 1 ns to 1 s Time accuracy²: ±(0.5% of the setting⁴ + 1 ns) Minimum time detection width²: 2 ns (typical value⁵)</p> <p>TV: Activates a trigger on the video signal of various formats: NTSC, PAL, SECAM, 1080/60i, 1080/50i, 720/60p, 480/60p, 1080/25p, 1080/24p, 1080/24sF, and 1080/60p CH1 is the only input channel. Field number and line number selectable.</p> <p>Logic: Trigger occurs on the edge of the clock bit with respect to the True/False condition of the parallel pattern of multiple logic inputs. If the clock bit is set to Don't Care, trigger occurs on the Enter or Exit condition of the True/False condition of the parallel pattern. Parallel pattern is the AND of the statuses of the bits of Pod A and B (16 bits) Clock bit is an arbitrary bit of Pod A and B (16 bits).</p> <ul style="list-style-type: none"> Condition A and Condition B are parallel patterns set using High, Low, and Don't Care on each channel CH1 to CH8/4¹.
Trigger gate	<p>Trigger can be activated only when the trigger condition is met when the input from the trigger gate input terminal (TRIG GATE IN) is active. Active level can be set to high or low.</p>

- 1 The maximum number of channels varies depending on the model.
- 2 Under standard operating conditions (see section 17.12) after the warm-up and calibration.
- 3 Under standard operating conditions (see section 17.12) after the warm-up.
- 4 The value of T2 for T1<Pulse<T2.
- 5 Typical value represents a typical or average value. It is not strictly warranted.

17.4 Time Axis

Item	Specifications																
Time axis range	1 ns/div to 50 s/div (when the record length is greater than or equal to 10 kW) 1 ns/div to 5 s/div (when the record length is equal to 1 kW)																
Time base accuracy ¹	±(0.005%)																
Time axis precision ¹	±(0.005% + 50 ps + 1 digit) ²																
External clock input (EXT CLOCK IN)	<table border="0"> <tr> <td>Connector type</td> <td>BNC</td> </tr> <tr> <td>Maximum input voltage</td> <td>±40 V (DC+ACpeak) or 28 Vrms when the frequency is 10 kHz or less.</td> </tr> <tr> <td>Input frequency range</td> <td>40 Hz to 20 MHz (continuous clock only)</td> </tr> <tr> <td>Sampling jitter</td> <td>±1.25 ns or less</td> </tr> <tr> <td>Minimum input amplitude</td> <td>0.1 V_{P-P}</td> </tr> <tr> <td>Threshold level</td> <td>±2 V (resolution is 5 mV)</td> </tr> <tr> <td>Input impedance</td> <td>Approx. 1 MΩ and 22 pF</td> </tr> <tr> <td>Minimum pulse width</td> <td>10 ns or more for high and low.</td> </tr> </table>	Connector type	BNC	Maximum input voltage	±40 V (DC+ACpeak) or 28 Vrms when the frequency is 10 kHz or less.	Input frequency range	40 Hz to 20 MHz (continuous clock only)	Sampling jitter	±1.25 ns or less	Minimum input amplitude	0.1 V _{P-P}	Threshold level	±2 V (resolution is 5 mV)	Input impedance	Approx. 1 MΩ and 22 pF	Minimum pulse width	10 ns or more for high and low.
Connector type	BNC																
Maximum input voltage	±40 V (DC+ACpeak) or 28 Vrms when the frequency is 10 kHz or less.																
Input frequency range	40 Hz to 20 MHz (continuous clock only)																
Sampling jitter	±1.25 ns or less																
Minimum input amplitude	0.1 V _{P-P}																
Threshold level	±2 V (resolution is 5 mV)																
Input impedance	Approx. 1 MΩ and 22 pF																
Minimum pulse width	10 ns or more for high and low.																

1 Under standard operating conditions (see section 17.12) after the warm-up.

2 1 digit is the amount of time that cannot be determined due to sampling error.

17.5 Display

Item	Specifications
Display	8.4" color TFT LCD monitor
Display screen size	170.9 mm (width) × 129.6 mm (height)
Total number of pixels*	640×480
Display resolution of the waveform display	500×384

* Liquid crystal display may include few defective pixels (within 20 ppm with respect to the total number of pixels including RGB). There may be few pixels on the liquid crystal display that do not turn ON all the time or remains ON all the time. Note that these are not malfunctions.

17.6 Function

Acquisition and Display

Item	Specifications
Acquisition mode	Select from 4 acquisition modes: normal, envelope, averaging, and box average.
Sampling mode	Switch between realtime sampling and repetitive sampling at some of the time axis settings.
Record length	1 kW, 10 kW, 50 kW, 100 kW, 250 kW, 500 kW, 1 MW, 2 MW, 4 MW, 8 MW, and 16 MW (8 MW and 16 MW are available only on the 16 MW memory model.)
Zoom	Expand the displayed waveform along the time axis (up two locations using separate zoom rates)
Display format	Split display of analog waveforms (1, 2, 3, 4, 6, and 8 windows (1, 2, 3, 4, and 6 windows on the 4-channel model) and a logic window for logic waveforms (optional).
Display interpolation	Select interpolation OFF (dot display of sample points), sine interpolation display, linear interpolation display, or pulse interpolation display.
Graticule	Select from three graticule types.
Auxiliary display ON/OFF	Turn ON/OFF the scaled values and waveform labels.
X-Y display	Displays two X-Y waveforms of XY1 and XY2.
Accumulation	Accumulates waveforms on the display. Select persistence mode or color grade mode.
Snapshot	Retains the current displayed waveform on the screen. Snapshot waveforms can be saved and loaded.
Clearing traces	Clears the displayed waveform.

Vertical and Horizontal Axes

Item	Specifications
Channel ON/OFF	ON/OFF on each channel CH1 to CH8/4*
Input filter	Set 100-MHz or 20-MHz bandwidth limit on each channel CH1 to CH8/4*.
Vertical position	Waveforms can be moved vertically in the range of ± 4 div from the center of the waveform display frame.
Linear scaling	Set the scaling factor, offset value, and unit on each channel CH1 to CH8/4*.
Roll mode	Roll mode display is enabled when the trigger mode is set to auto, auto level, or single at the following time axis settings. 1 MW or less: 50 ms/div to 50 s/div (except 50 ms to 5 s/div for 1 kW) 2 MW: 100 ms/div to 50 s/div 4 MW: 200 ms/div to 50 s/div 8 MW: 500 ms/div to 50 s/div 16 MW: 1 s/div to 50 s/div

* The maximum number of channels varies depending on the model.

Computation, Analysis, and Search

Item	Specifications
Computation	+ , - , \times , binary computation, invert, differentiation, integration, and power spectrum. The maximum record length that can be computed is as follows: 4 MW memory model (701450 and 701470): All record lengths. 16 MW memory model (701460 and 701480): 8 MW when interleave mode is ON 4 MW when interleave mode is OFF However, select the range (1 kW or 10 kW) for power spectrum computation (FFT).
Phase shift	Waveforms can be observed by shifting the phase of CH1 to CH8/4 ¹ . Computation is performed using the phase-shifted waveforms. The maximum record length that can be phase shifted is 8 MW.
User-defined computation (optional)	Equations obtained by arbitrarily combining the following operators. + , - , \times , / , ABS, SQRT, LOG, EXP, NEG, SIN, COS, TAN, ATAN, PH, DIF, DDIF, INTG, IINTG, BIN, P2, P3, F1, F2, FV, PWHL, PWLL, PWXX, DUTYH, DUTYL, FILT1, FILT2, HLBT, MEAN, LS-, PS-, PSD-, CS-, TF-, CH-, MAG , LOGMAG, PHASE, REAL, and IMAG The maximum record length is the same as the normal computation shown above. However, computation is performed on up to 2 MW from the computation start point.
History search	Search for and display waveforms from the history memory that meet specified conditions. Select the search method from the following two types. Zone: Set an area on the screen, then extract and display only those waveforms that pass through the area (Pass mode), or do not pass through the area (Bypass mode). Parameter: Extract and display only the results of the automated measurement of waveform parameters that meet the specified condition.
Search & zoom	Search a section of the displayed waveform data and display the section expanded. Select the search method from the following five types. Edge: Counts the rising and falling edges and automatically searches an arbitrary edge. Serial pattern: Automatically searches serial patterns of up to 64 bits synchronized or not synchronized to the clock. Parallel pattern: Automatically searches parallel patterns of CH1 to CH8/4 ¹ , MATH1, MATH2, and 16 bits of logic (optional). Pulse width: Automatically searches the locations where the pulse width meets the specified condition. Auto scroll: The zoom position can be automatically scrolled.
Cursor measurements	The following cursors are selectable. Horizontal, Vertical, Marker, and Degree
Automated measurement of waveform parameters	Capable of performing automated measurement of waveform parameters. Automated measurement of waveform parameters within one cycle (P-P through Int2XY), statistical processing of waveform parameters, and statistical processing on the waveform parameters of historical data. P-P, Max, Min, Avg, Rms, Sdev, High, Low, +OShot, -OShot, Int1TY, Int2TY, Int1XY, Int2XY, Freq, Period, Rise, Fall, +Width, -Width, Burst1, Burst2, Pulse, AvgFreq, AvgPeriod, and Delay (between channels) Statistical processing results Statistics: Min, Max, Avg, Cnt, and Sdv Measurement of waveform parameters in dual areas is also possible. Computation can be performed between waveform parameters measured in dual areas and constants. Operators are + , - , * , and /.
GO/NO-GO determination	The following two types of GO/NO-GO determination are available <ul style="list-style-type: none"> Determination using zones on the screen Determination using the result of the automated measurement of waveform parameters Specify an action for NO-GO result. Possible actions are screen image data output, waveform data storage, buzzer notification, and e-mail transmission ² .

17.6 Function

Item	Specifications
SPI signal analysis/search	Data analysis and search by applying Clock to CH1, Data1 to CH2, Data2 to CH3, and CS signals to CH4 to CH8 ¹ or bit 0 to bit 7 of logic input (optional) Pod A. Analysis function: Display the status of Data1, Data2, and CS in unit of bytes (8 bits) of serial data. The analysis results can be output to a file. Search function: Search arbitrary or specific data patterns based on the analysis results.

- 1 The maximum number of channels varies depending on the model.
- 2 When the Ethernet interface option is installed.

Saving and Printing of the Screen Image Data

Item	Specifications
Built-in printer (optional)	Prints screen image data.
External printer	Outputs the screen image to an external printer via the USB PERIPHERAL terminal or the Ethernet network ¹ . Supports page description languages and printer types such as ESC/P, ESC/P2, LIPS3, PCL5, Post Script (only via the Ethernet network ¹), and BJ
Floppy disk or Zip disk ² , SCSI ³ , network drive ¹ , USB storage, and PC card	Output data format: PostScript, TIFF, BMP, JPEG, and PNG

- 1 When the Ethernet interface option is installed.
- 2 Select the floppy disk drive or Zip drive for the built-in storage medium drive at the time of purchase.
- 3 When the SCSI option is installed.

Data Storage

Item	Specifications
History memory	When interleave mode is ON: Automatically save up to 4096 acquisition data points. When interleave mode is OFF: Automatically save up to 2048 acquisition data points.
Floppy disk or Zip disk ¹ , SCSI ² , network drive ³ , USB storage, and PC card	Saves setup data, waveform data, and various data

- 1 Select the floppy disk drive or Zip drive for the built-in storage medium drive at the time of purchase.
- 2 When the SCSI option is installed.
- 3 When the Ethernet interface option is installed.

Other Functions

Item	Specifications
Initialization	Resets settings to the factory default (excluding date/time setting, communication interface settings, SCSI ID number setting, settings stored to the internal memory using the store/recall function, and language setting)
Auto setup	Automatically set the optimum voltage axis, time axis, trigger, and other settings for the input signal.
Store/Recall	Store to and recall from the DL7400 internal memory up to three sets of arbitrary setup data.
Preset	Presets for CMOS (5 V), CMOS (3.3 V), ECL, and user settings.
Action-on-trigger	Output screen image data, saves waveform data, activates buzzer notification, or sends e-mail messages each time a trigger occurs.
Mail transmission ¹	Periodically send the status of the DL7400 to a specified mail address via the Ethernet network. Can also send information as an action for GO/NO-GO determination and action-on-trigger.
Calibration	Auto calibration and manual calibration available.
Deskew	Correct the delay of the acquired waveforms on each channel. Adjustment range is ± 100 ns (0.01 ns resolution)
Environment settings	Set the screen color, date/time, message language, and click sound ON/OFF
Probe compensation signal output	Outputs a signal (rectangular signal of approx. 1 Vp-p and approx. 1 kHz) from the probe compensation output terminal on the front panel
Overview	Check the system status of the DL7400.
Self test	Memory test, key test, printer test, FDD/Zip drive ² test, SCSI test, and accuracy test are possible.
Help	Displays help concerning the settings (select English or Japanese)
Thumbnail	Shows thumbnails of the screen image data

- 1 When the Ethernet interface option is installed
- 2 Select the floppy disk drive or Zip drive for the built-in storage medium drive at the time of purchase.

17.7 Built-in Printer (Optional)

Item	Specifications
Printing system	Thermal line dot system
Dot density	8 dots/mm
Paper width	112 mm

17.8 Storage

Built-in Floppy Disk Drive*

Item	Specifications
Number of drives	1
Size	3.5 inch
Capacity	1.44 MB

* Select the floppy disk drive or Zip drive for the built-in storage medium drive at the time of purchase.

Built-in Zip Drive*

Item	Specifications
Number of drives	1
Capacity	100 MB or 250 MB

* Select the floppy disk drive or Zip drive for the built-in storage medium drive at the time of purchase.

SCSI (Optional)

Item	Specifications
Standard	Conforms to ANSIX3.131-1986 for SCSI (Small Computer System Interface)
Connector	Half pitch 50 pins
Connector pin assignment	Unbalanced (single-ended)

PC Card Interface

Item	Specifications
Number of slots	1
Supported cards	Flash ATA memory card (PC card TYPE II)

USB Storage*

Item	Specifications
Supports USB mass storage	USBmass storage class hard disk drive, MO disk drive, and flash memory.

* For details on the interface specifications, see section 17.9.

17.9 USB Peripheral Interface

Item	Specifications
Connector type	USB type A connector (receptacle)
Electrical and mechanical specifications	Conforms to USB Revision 1.1
Data rate	12 Mbps max.
Supported keyboards	104 keyboard (US), 109 keyboard (Japanese), and 89 keyboard (US and Japanese) conforming to USB HID Class Version 1.1
Supported printers	ESC/P, ESC/P2, LIPS3, PCL5, and BJ (can be used on models that support the BJC-35V native commands) that support USB (USB Printer Class Version 1.0)
Supported mouse	Mouse conforming to USB HID Class Version 1.1
Supports USB mass storage	USB mass storage class hard disk drive, MO disk drive, and flash memory
Power supply	5 V, 500 mA* (per port)
Number of ports	2

* Devices with maximum consumption currents exceeding 100 mA cannot be connected to two ports at the same time.

17.10 Auxiliary I/O Section

External Trigger Input¹ and Trigger Gate Input¹

Item	Specifications
Connector type	BNC
Input bandwidth ²	DC to 100 MHz ³
Input impedance	Approx. 1 M Ω and 22 pF
Maximum input voltage	± 40 V (DC+ACpeak) or 28 Vrms when the frequency is 10 kHz or less.
Trigger level	± 2 V (resolution of 5 mV)

- 1 The external trigger input terminal (EXT TRIG IN)/trigger gate input terminal (TRIG GATE IN) is also used as an external clock input terminal (EXT CLOCK IN). See the specifications of the external clock input (see section 17.4).
- 2 Under standard operating conditions (see section 17.12) after the warm-up.
- 3 The input frequency range when using the terminal as a trigger gate input is DC to 50 MHz.

Trigger Output (TRIG OUT)

Item	Specifications
Connector type	BNC
Output level	TTL
Output logic	$\overline{1}$ (Negative)
Output delay time	50 ns max
Output hold time	1 μ s minimum for low level and 100 ns minimum for high level

Video Signal Output (VIDEO OUT (VGA))

Item	Specifications
Connector type	15-pin D-Sub receptacle
Output type	VGA compatible

Probe Power Supply Terminal

Item	Specifications
Number of output terminals	4 (A to D) (4 optional terminals (E to H) can be added on the 8-channel model).
Output voltage	+12 V (Up to ± 500 mA on each pair of terminals A and E; B and F; C and G; and D and H.)
Probes that can be used	FET probe (700939), current probe (700937, 701930, 701931, 701932, or 701933), and differential probe (701920 or 701922)

17.11 Computer Interface

GP-IB

Item	Specifications
Electrical and mechanical specifications	Conforms to IEEE St'd 488-1978 (JIS C 1901-1987).
Functional specifications	SH1, AH1, T6, L4, SR1, RL1, PP0, DC1, DT0, and C0
Protocol	Conforms to IEEE St'd 488.2-1987.
Code	ISO (ASCII) code
Mode	Addressable mode
Address	Specify a talker/listener address between 0 and 30.
Clear remote mode	Remote mode can be cleared using the SHIFT+CLEAR key (except during Local Lockout).

USB

Item	Specifications
Connector type	USB type B connector (receptacle)
Electrical and mechanical specifications	Conforms to USB Revision 1.1.
Data rate	12 Mbps max.
Number of ports	1
PC system supported	PC running Windows 98 SE, Windows Me, Windows 2000, or Windows XP with a standard USB port (a separate driver is needed to connect to a PC).

Ethernet (Optional)

Item	Specifications
Number of communication ports	1
Electrical and mechanical specifications	Conforms to IEEE802.3.
Transmission system	Ethernet (100BASE-TX/10BASE-T)
Transmission rate	100 Mbps max.
Communication protocol	TCP/IP
Supported services	FTP server, FTP client (network drive), LPR client (network printer), SMTP client (mail transmission), Web server, DHCP, DNS, SNTTP*, and WebDAV*
Connector type	RJ-45 connector

* SNTTP and WebDAV are available only on models with a firmware version of 1.30 or later.

17.12 General Specifications

Item	Specifications
Standard operating conditions	Ambient temperature: 23±2°C Ambient humidity: 55±10% RH Error in supply voltage and frequency: Within 1% of rating
Warm-up time	At least 30 minutes
Storage conditions	Temperature: -20 to 60°C, -20 to 50°C (for the -J2: built-in Zip drive model) Humidity: 20 to 80% RH (no condensation)
Operating Conditions	Temperature: 5 to 40°C Humidity: 20 to 80% RH (when the printer is not used) (no condensation) 35 to 80% RH (when the printer is used) (no condensation)
Storage altitude	3000 m or less
Operating altitude	2000 m or less
Rated supply voltage	100 to 120 VAC/220 to 240 VAC
Permitted supply voltage range	90 to 132 VAC/198 to 264 VAC
Rated supply voltage frequency	50/60 Hz
Permitted supply voltage frequency range	48 to 63 Hz
Power fuse	250 V/6.3 A time lag, VDE/SEMKO/UL/CSA certified. Inside the case. Cannot be replaced by the user.
Maximum power consumption	320 VA
Withstanding voltage (between power supply and case)	1.5 kVAC for one minute.
Insulation resistance (between power supply and case)	10 MΩ or more at 500 VDC.
External dimensions (details on the next page)	373 mm (W) × 210.5 mm (H) × 355.3 mm (D) (When the printer cover is closed. Excludes the handle and other projections.)
Weight (only the main unit without the printer)	Approx. 10 kg
Instrument's cooling method	Forced air cooling, exhaust from rear.
Installation position	Horizontal (the stand can be used to tilt the DL7400), stacking prohibited.
Recommended calibration period	1 year
Battery backup	Setup data and clock are backed up with the internal lithium battery Battery life: Approx. 5 years (at ambient temperature of 23°C)
Standard accessories	<ul style="list-style-type: none"> • Power Cord: 1 piece • 400 MHz passive probe: 4 pieces • Soft case: B9969ET, 1 piece • Front panel protection cover: B8051DP, 1 piece • Printer roll paper: 1 roll (for /B5 suffix code) • Rubber feet: 4 pieces (2 A9088ZM) • User's manual: 1 piece • Operation guide: 1 piece • Communication Interface User's Manual: 1 piece (CD-ROM) • Power Supply Analysis Function User's Manual: 1 piece (for /G4 suffix code)

Item	Specifications
Safety Standards	<p>Complying standards EN61010-1</p> <ul style="list-style-type: none"> • Overvoltage category II¹ • Pollution degree 2²
Emission	<p>Complying standards</p> <ul style="list-style-type: none"> • EN61326 Class A, C-Tick AS/NZS CISPR11 (applies to 701450, 701460, 701470, 701480, 700988, 700939, 701941, 701980, and 701981) • EN61000-3-2 • EN61000-3-3 • This product is a Class A (for industrial environment) product. Operation of this product in a residential area may cause radio interference in which case the user is required to correct the interference. <p>Cable condition</p> <ul style="list-style-type: none"> • External trigger input/external clock input/trigger gate input terminal Use a BNC cable³ and attach a ferrite core (TDK: ZCAT2035-0930A, YOKOGAWA: A1190MN) on one end (DL7400 end). • Trigger output terminal Same as the external trigger input terminal above. • RGB video signal output (VIDEO OUT) terminal Use a 15-pin D-Sub VGA shielded cable³. • SCSI connector Use a SCSI shielded cable³ and attach a ferrite core (TDK: ZCAT2035-0930A, YOKOGAWA: A1190MN) on one end (DL7400 end). • USB PERIPHERAL connector Attach a ferrite core (TDK: ZCAT1325-0530A, YOKOGAWA: A1181MN) on one end (DL7400 end) of the USB cable³. • USB interface connector Attach a ferrite core (TDK: ZCAT1325-0530A, YOKOGAWA: A1181MN) on one end (DL7400 end) of the USB cable³. • Ethernet interface connector Use a Ethernet interface cable⁴ and attach a ferrite core (TDK: ZCAT2035-0930A, YOKOGAWA: A1190MN) on one end (DL7400 end). • Probe power terminal Attach a ferrite core (TDK: ZCAT1325-0530A, YOKOGAWA: A1181MN) on one end (DL7400 end) of the cable. • Logic probe input connector Attach a ferrite core (TDK: ZCAT2035-0930A, YOKOGAWA: A1190MN) on one end (DL7400 end) of the cable.
Immunity	<p>Complying standards</p> <ul style="list-style-type: none"> • EN61326 industrial environment (applies to 701450, 701460, 701470, 701480, 700988, 700939, and 701981) <p>Influence in the immunity environment</p> <ul style="list-style-type: none"> • Noise increase: $\leq \pm 200$ mV (when using 700988) $\leq \pm 400$ mV (when using 700939) No influence (when using 701981) • Test conditions <ul style="list-style-type: none"> When using the 700988: 1 GS/s, envelope mode, 20 MHz BWL, 1 MΩ input coupling, 50 mV/div (10:1 probe attenuation setting), and 50-Ω termination at the probe tip. When using the 700939: 1 GS/s, envelope mode, 20 MHz BWL, 50 Ω input coupling, 100 mV/div (10:1 probe attenuation setting), 50-Ω termination at the probe tip. When using the 701981: 1 GS/s, envelope mode, and 50-Ω termination at the probe tip. • Cable condition Same as the cable condition for emission above.

- 1 The Overvoltage Category (Installation Category) is a value used to define the transient overvoltage condition and includes the impulse withstand voltage regulation. II applies to electrical equipment that is powered by a fixed installation such as a distribution board.
- 2 Pollution Degree applies to the degree of adhesion of a solid, liquid, or gas which deteriorates withstand voltage or surface resistivity. Pollution Degree 2 applies to normal indoor atmospheres (with only non-conductive pollution).
- 3 Use cables of length 3 m or less.
- 4 Use cables of length 30 m or less.

17.13 External Dimensions

Unit: mm

Rear View

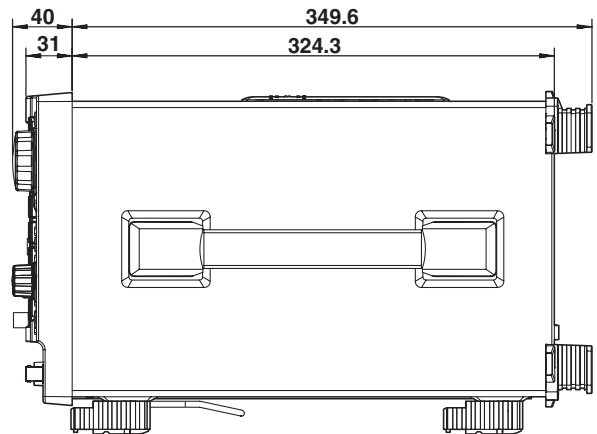
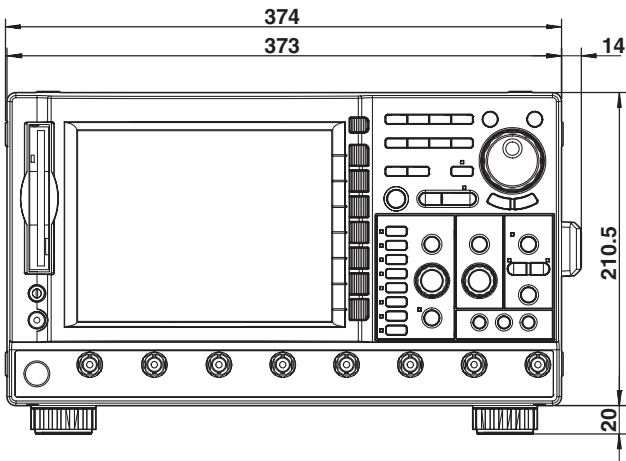
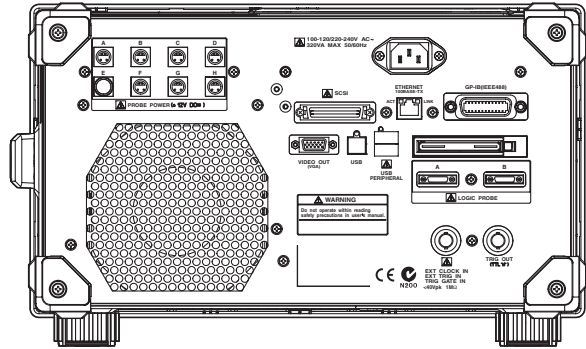
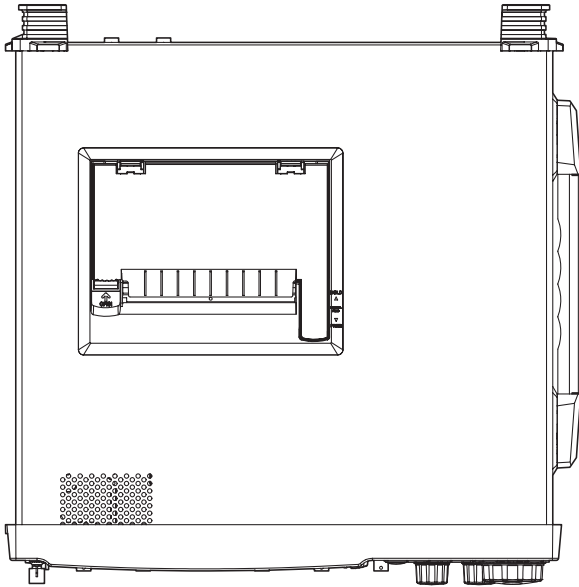

If not specified, the tolerance is $\pm 3\%$. However, in cases of less than 10 mm, the tolerance is ± 0.3 mm.

Appendix 1 Relationship between the Time Axis Setting, Sample Rate and Record Length

Specified Record Length: 1 kW

Rep: Repetitive sampling mode

Setting T/div	When set to a mode other than envelope mode								When set to envelope mode			
	When interleave mode is OFF				When interleave mode is ON				When interleave mode is OFF		When interleave mode is ON	
	Rep: OFF		Rep: ON		Rep: OFF		Rep: ON		Sample rate (S/s)	Display record length (Word)	Sample rate (S/s)	Display record length (Word)
	Sample rate (S/s)	Display record length (Word)	Sample rate (S/s)	Display record length (Word)	Sample rate (S/s)	Display record length (Word)	Sample rate (S/s)	Display record length (Word)	Sample rate (S/s)	Display record length (Word)	Sample rate (S/s)	Display record length (Word)
50 s	These time axis settings are not possible when the record length is 1 kW.											
20 s												
10 s												
5 s	20	1 k	20	1 k	20	1 k	20	1 k	800 M	1 k	800 M	1 k
2 s	50	1 k	50	1 k	50	1 k	50	1 k	800 M	1 k	800 M	1 k
1 s	100	1 k	100	1 k	100	1 k	100	1 k	800 M	1 k	800 M	1 k
500 ms	200	1 k	200	1 k	200	1 k	200	1 k	800 M	1 k	800 M	1 k
200 ms	500	1 k	500	1 k	500	1 k	500	1 k	800 M	1 k	800 M	1 k
100 ms	1 k	1 k	1 k	1 k	1 k	1 k	1 k	1 k	800 M	1 k	800 M	1 k
50 ms	2 k	1 k	2 k	1 k	2 k	1 k	2 k	1 k	800 M	1 k	800 M	1 k
20 ms	5 k	1 k	5 k	1 k	5 k	1 k	5 k	1 k	800 M	1 k	800 M	1 k
10 ms	10 k	1 k	10 k	1 k	10 k	1 k	10 k	1 k	800 M	1 k	800 M	1 k
5 ms	20 k	1 k	20 k	1 k	20 k	1 k	20 k	1 k	800 M	1 k	800 M	1 k
2 ms	50 k	1 k	50 k	1 k	50 k	1 k	50 k	1 k	800 M	1 k	800 M	1 k
1 ms	100 k	1 k	100 k	1 k	100 k	1 k	100 k	1 k	800 M	1 k	800 M	1 k
500 μs	200 k	1 k	200 k	1 k	200 k	1 k	200 k	1 k	800 M	1 k	800 M	1 k
200 μs	500 k	1 k	500 k	1 k	500 k	1 k	500 k	1 k	800 M	1 k	800 M	1 k
100 μs	1 M	1 k	1 M	1 k	1 M	1 k	1 M	1 k	800 M	1 k	800 M	1 k
50 μs	2 M	1 k	2 M	1 k	2 M	1 k	2 M	1 k	800 M	1 k	800 M	1 k
20 μs	5 M	1 k	5 M	1 k	5 M	1 k	5 M	1 k	800 M	1 k	800 M	1 k
10 μs	10 M	1 k	10 M	1 k	10 M	1 k	10 M	1 k	800 M	1 k	800 M	1 k
5 μs	20 M	1 k	20 M	1 k	20 M	1 k	20 M	1 k	800 M	1 k	800 M	1 k
2 μs	50 M	1 k	50 M	1 k	50 M	1 k	50 M	1 k	800 M	1 k	800 M	1 k
1 μs	100 M	1 k	100 M	1 k	100 M	1 k	100 M	1 k	800 M	1 k	800 M	1 k
500 ns	200 M	1 k	200 M	1 k	200 M	1 k	200 M	1 k	800 M	1 k	800 M	1 k
200 ns	500 M	1 k	500 M	1 k	500 M	1 k	500 M	1 k	1 G	1 k	1 G	1 k
100 ns	1 G	1 k	1 G	1 k	1 G	1 k	1 G	1 k	Set to normal mode even if envelope mode is specified.			
50 ns	1 G	500	2 G	1 k	2 G	1 k	2 G	1 k				
20 ns	1 G	200	5 G	1 k	2 G	400	5 G	1 k				
10 ns	1 G	100	10 G	1 k	2 G	200	10 G	1 k				
5 ns	20 G	1 k	20 G	1 k	20 G	1k	20 G	1 k				
2 ns	50 G	1 k	50 G	1 k	50 G	1k	50 G	1 k				
1 ns	100 G	1 k	100 G	1 k	100 G	1k	100 G	1 k	*			

* The values inside the thick frame are for repetitive sampling mode.

Appendix 1 Relationship between the Time Axis Setting, Sample Rate and Record Length

Specified Record Length: 10 kW

Rep: Repetitive sampling mode

Setting T/div	When set to a mode other than envelope mode								When set to envelope mode			
	When interleave mode is OFF				When interleave mode is ON				When interleave mode is OFF		When interleave mode is ON	
	Rep: OFF		Rep: ON		Rep: OFF		Rep: ON					
	Sample rate (S/s)	Display record length (Word)	Sample rate (S/s)	Display record length (Word)	Sample rate (S/s)	Display record length (Word)	Sample rate (S/s)	Display record length (Word)	Sample rate (S/s)	Display record length (Word)	Sample rate (S/s)	Display record length (Word)
50 s	20	10 k	20	10 k	20	10 k	20	10 k	800 M	10 k	800 M	10 k
20 s	50	10 k	50	10 k	50	10 k	50	10 k	800 M	10 k	800 M	10 k
10 s	100	10 k	100	10 k	100	10 k	100	10 k	800 M	10 k	800 M	10 k
5 s	200	10 k	200	10 k	200	10 k	200	10 k	800 M	10 k	800 M	10 k
2 s	500	10 k	500	10 k	500	10 k	500	10 k	800 M	10 k	800 M	10 k
1 s	1 k	10 k	1 k	10 k	1 k	10 k	1 k	10 k	800 M	10 k	800 M	10 k
500 ms	2 k	10 k	2 k	10 k	2 k	10 k	2 k	10 k	800 M	10 k	800 M	10 k
200 ms	5 k	10 k	5 k	10 k	5 k	10 k	5 k	10 k	800 M	10 k	800 M	10 k
100 ms	10 k	10 k	10 k	10 k	10 k	10 k	10 k	10 k	800 M	10 k	800 M	10 k
50 ms	20 k	10 k	20 k	10 k	20 k	10 k	20 k	10 k	800 M	10 k	800 M	10 k
20 ms	50 k	10 k	50 k	10 k	50 k	10 k	50 k	10 k	800 M	10 k	800 M	10 k
10 ms	100 k	10 k	100 k	10 k	100 k	10 k	100 k	10 k	800 M	10 k	800 M	10 k
5 ms	200 k	10 k	200 k	10 k	200 k	10 k	200 k	10 k	800 M	10 k	800 M	10 k
2 ms	500 k	10 k	500 k	10 k	500 k	10 k	500 k	10 k	800 M	10 k	800 M	10 k
1 ms	1 M	10 k	1 M	10 k	1 M	10 k	1 M	10 k	800 M	10 k	800 M	10 k
500 μs	2 M	10 k	2 M	10 k	2 M	10 k	2 M	10 k	800 M	10 k	800 M	10 k
200 μs	5 M	10 k	5 M	10 k	5 M	10 k	5 M	10 k	800 M	10 k	800 M	10 k
100 μs	10 M	10 k	10 M	10 k	10 M	10 k	10 M	10 k	800 M	10 k	800 M	10 k
50 μs	20 M	10 k	20 M	10 k	20 M	10 k	20 M	10 k	800 M	10 k	800 M	10 k
20 μs	50 M	10 k	50 M	10 k	50 M	10 k	50 M	10 k	800 M	10 k	800 M	10 k
10 μs	100 M	10 k	100 M	10 k	100 M	10 k	100 M	10 k	800 M	10 k	800 M	10 k
5 μs	200 M	10 k	200 M	10 k	200 M	10 k	200 M	10 k	800 M	10 k	800 M	10 k
2 μs	500 M	10 k	500 M	10 k	500 M	10 k	500 M	10 k	1 G	10 k	1 G	10 k
1 μs	1 G	10 k	1 G	10 k	1 G	10 k	1 G	10 k	* Set to normal mode even if envelope mode is specified.			
500 ns	1 G	5 k	2 G	10 k	2 G	10 k	2 G	10 k				
200 ns	1 G	2 k	5 G	10 k	2 G	4 k	5 G	10 k				
100 ns	1 G	1 k	10 G	10 k	2 G	2 k	10 G	10 k				
50 ns	1 G	500	20 G	10 k	2 G	1 k	20 G	10 k				
20 ns	1 G	200	50 G	10 k	2 G	400	50 G	10 k				
10 ns	1 G	100	100 G	10 k	2 G	200	100 G	10 k				
5 ns	100 G	5 k	100 G	5 k	100 G	5 k	100 G	5 k				
2 ns	100 G	2 k	100 G	2 k	100 G	2 k	100 G	2 k				
1 ns	100 G	1 k	100 G	1 k	100 G	1 k	100 G	1 k				

* The values inside the thick frame are for repetitive sampling mode.

Appendix 1 Relationship between the Time Axis Setting, Sample Rate and Record Length

Specified Record Length: 50 kW

Rep: Repetitive sampling mode

Setting T/div	When set to a mode other than envelope mode								When set to envelope mode			
	When interleave mode is OFF				When interleave mode is ON				When interleave mode is OFF		When interleave mode is ON	
	Rep: OFF		Rep: ON		Rep: OFF		Rep: ON					
	Sample rate (S/s)	Display record length (Word)	Sample rate (S/s)	Display record length (Word)	Sample rate (S/s)	Display record length (Word)	Sample rate (S/s)	Display record length (Word)	Sample rate (S/s)	Display record length (Word)	Sample rate (S/s)	Display record length (Word)
50 s	100	50 k	100	50 k	100	50 k	100	50 k	800 M	50 k	800 M	50 k
20 s	200	40 k	200	40 k	200	40 k	200	40 k	800 M	40 k	800 M	40 k
10 s	500	50 k	500	50 k	500	50 k	500	50 k	800 M	50 k	800 M	50 k
5 s	1 k	50 k	1 k	50 k	1 k	50 k	1 k	50 k	800 M	50 k	800 M	50 k
2 s	2 k	40 k	2 k	40 k	2 k	40 k	2 k	40 k	800 M	40 k	800 M	40 k
1 s	5 k	50 k	5 k	50 k	5 k	50 k	5 k	50 k	800 M	50 k	800 M	50 k
500 ms	10 k	50 k	10 k	50 k	10 k	50 k	10 k	50 k	800 M	50 k	800 M	50 k
200 ms	20 k	40 k	20 k	40 k	20 k	40 k	20 k	40 k	800 M	40 k	800 M	40 k
100 ms	50 k	50 k	50 k	50 k	50 k	50 k	50 k	50 k	800 M	50 k	800 M	50 k
50 ms	100 k	50 k	100 k	50 k	100 k	50 k	100 k	50 k	800 M	50 k	800 M	50 k
20 ms	200 k	40 k	200 k	40 k	200 k	40 k	200 k	40 k	800 M	40 k	800 M	40 k
10 ms	500 k	50 k	500 k	50 k	500 k	50 k	500 k	50 k	800 M	50 k	800 M	50 k
5 ms	1 M	50 k	1 M	50 k	1 M	50 k	1 M	50 k	800 M	50 k	800 M	50 k
2 ms	2 M	40 k	2 M	40 k	2 M	40 k	2 M	40 k	800 M	40 k	800 M	40 k
1 ms	5 M	50 k	5 M	50 k	5 M	50 k	5 M	50 k	800 M	50 k	800 M	50 k
500 μs	10 M	50 k	10 M	50 k	10 M	50 k	10 M	50 k	800 M	50 k	800 M	50 k
200 μs	20 M	40 k	20 M	40 k	20 M	40 k	20 M	40 k	800 M	40 k	800 M	40 k
100 μs	50 M	50 k	50 M	50 k	50 M	50 k	50 M	50 k	800 M	50 k	800 M	50 k
50 μs	100 M	50 k	100 M	50 k	100 M	50 k	100 M	50 k	800 M	50 k	800 M	50 k
20 μs	200 M	40 k	200 M	40 k	200 M	40 k	200 M	40 k	800 M	40 k	800 M	40 k
10 μs	500 M	50 k	500 M	50 k	500 M	50 k	500 M	50 k	1 G	50 k	1 G	50 k
5 μs	1 G	50 k	1 G	50 k	1 G	50 k	1 G	50 k	Set to normal mode even if envelope mode is specified.			
2 μs	1 G	20 k	2 G	40 k	2 G	40 k	2 G	40 k				
1 μs	1 G	10 k	5 G	50 k	2 G	20 k	5 G	50 k				
500 ns	1 G	5 k	10 G	50 k	2 G	10 k	10 G	50 k				
200 ns	1 G	2 k	20 G	40 k	2 G	4 k	20 G	40 k				
100 ns	1 G	1 k	50 G	50 k	2 G	2 k	50 G	50 k				
50 ns	1 G	500	100 G	50 k	2 G	1 k	100 G	50 k				
20 ns	1 G	200	100 G	20 k	2 G	400	100 G	20 k				
10 ns	1 G	100	100 G	10 k	2 G	200	100 G	10 k				
5 ns	100 G	5 k	100 G	5 k	100 G	5 k	100 G	5 k				
2 ns	100 G	2 k	100 G	2 k	100 G	2 k	100 G	2 k				
1 ns	100 G	1 k	100 G	1 k	100 G	1 k	100 G	1 k				

* The values inside the thick frame are for repetitive sampling mode.

Appendix 1 Relationship between the Time Axis Setting, Sample Rate and Record Length

Specified Record Length: 100 kW

Rep: Repetitive sampling mode

Setting T/div	When set to a mode other than envelope mode								When set to envelope mode			
	When interleave mode is OFF				When interleave mode is ON				When interleave mode is OFF		When interleave mode is ON	
	Rep: OFF		Rep: ON		Rep: OFF		Rep: ON		Sample rate (S/s)	Display record length (Word)	Sample rate (S/s)	Display record length (Word)
	Sample rate (S/s)	Display record length (Word)	Sample rate (S/s)	Display record length (Word)	Sample rate (S/s)	Display record length (Word)	Sample rate (S/s)	Display record length (Word)	Sample rate (S/s)	Display record length (Word)	Sample rate (S/s)	Display record length (Word)
50 s	200	100 k	200	100 k	200	100 k	200	100 k	800 M	100 k	800 M	100 k
20 s	500	100 k	500	100 k	500	100 k	500	100 k	800 M	100 k	800 M	100 k
10 s	1 k	100 k	1 k	100 k	1 k	100 k	1 k	100 k	800 M	100 k	800 M	100 k
5 s	2 k	100 k	2 k	100 k	2 k	100 k	2 k	100 k	800 M	100 k	800 M	100 k
2 s	5 k	100 k	5 k	100 k	5 k	100 k	5 k	100 k	800 M	100 k	800 M	100 k
1 s	10 k	100 k	10 k	100 k	10 k	100 k	10 k	100 k	800 M	100 k	800 M	100 k
500 ms	20 k	100 k	20 k	100 k	20 k	100 k	20 k	100 k	800 M	100 k	800 M	100 k
200 ms	50 k	100 k	50 k	100 k	50 k	100 k	50 k	100 k	800 M	100 k	800 M	100 k
100 ms	100 k	100 k	100 k	100 k	100 k	100 k	100 k	100 k	800 M	100 k	800 M	100 k
50 ms	200 k	100 k	200 k	100 k	200 k	100 k	200 k	100 k	800 M	100 k	800 M	100 k
20 ms	500 k	100 k	500 k	100 k	500 k	100 k	500 k	100 k	800 M	100 k	800 M	100 k
10 ms	1 M	100 k	1 M	100 k	1 M	100 k	1 M	100 k	800 M	100 k	800 M	100 k
5 ms	2 M	100 k	2 M	100 k	2 M	100 k	2 M	100 k	800 M	100 k	800 M	100 k
2 ms	5 M	100 k	5 M	100 k	5 M	100 k	5 M	100 k	800 M	100 k	800 M	100 k
1 ms	10 M	100 k	10 M	100 k	10 M	100 k	10 M	100 k	800 M	100 k	800 M	100 k
500 μs	20 M	100 k	20 M	100 k	20 M	100 k	20 M	100 k	800 M	100 k	800 M	100 k
200 μs	50 M	100 k	50 M	100 k	50 M	100 k	50 M	100 k	800 M	100 k	800 M	100 k
100 μs	100 M	100 k	100 M	100 k	100 M	100 k	100 M	100 k	800 M	100 k	800 M	100 k
50 μs	200 M	100 k	200 M	100 k	200 M	100 k	200 M	100 k	800 M	100 k	800 M	100 k
20 μs	500 M	100 k	500 M	100 k	500 M	100 k	500 M	100 k	1 G	100 k	1 G	100 k
10 μs	1 G	100 k	1 G	100 k	1 G	100 k	1 G	100 k	* Set to normal mode even if envelope mode is specified.			
5 μs	1 G	50 k	2 G	100 k	2 G	100 k	2 G	100 k				
2 μs	1 G	25 k	5 G	100 k	2 G	40 k	5 G	100 k				
1 μs	1 G	10 k	10 G	100 k	2 G	20 k	10 G	100 k				
500 ns	1 G	5 k	20 G	100 k	2 G	10 k	20 G	100 k				
200 ns	1 G	2 k	50 G	100 k	2 G	4 k	50 G	100 k				
100 ns	1 G	1 k	100 G	100 k	2 G	2 k	100 G	100 k				
50 ns	1 G	500	100 G	50 k	2 G	1 k	100 G	50 k				
20 ns	1 G	200	100 G	20 k	2 G	400	100 G	20 k				
10 ns	1 G	100	100 G	10 k	2 G	200	100 G	10 k				
5 ns	100 G	5 k	100 G	5 k	100 G	5 k	100 G	5 k				
2 ns	100 G	2 k	100 G	2 k	100 G	2 k	100 G	2 k				
1 ns	100 G	1 k	100 G	1 k	100 G	1 k	100 G	1 k				

* The values inside the thick frame are for repetitive sampling mode.

Appendix 1 Relationship between the Time Axis Setting, Sample Rate and Record Length

Specified Record Length: 250 kW

Rep: Repetitive sampling mode

Setting T/div	When set to a mode other than envelope mode								When set to envelope mode			
	When interleave mode is OFF				When interleave mode is ON				When interleave mode is OFF		When interleave mode is ON	
	Rep: OFF		Rep: ON		Rep: OFF		Rep: ON		Sample rate (S/s)	Display record length (Word)	Sample rate (S/s)	Display record length (Word)
	Sample rate (S/s)	Display record length (Word)	Sample rate (S/s)	Display record length (Word)	Sample rate (S/s)	Display record length (Word)	Sample rate (S/s)	Display record length (Word)	Sample rate (S/s)	Display record length (Word)	Sample rate (S/s)	Display record length (Word)
50 s	500	250 k	500	250 k	500	250 k	500	250 k	800 M	250 k	800 M	250 k
20 s	1 k	200 k	1 k	200 k	1 k	200 k	1k	200 k	800 M	200 k	800 M	200 k
10 s	2 k	200 k	2 k	200 k	2 k	200 k	2k	200 k	800 M	200 k	800 M	200 k
5 s	5 k	250 k	5 k	250 k	5 k	250 k	5k	250 k	800 M	250 k	800 M	250 k
2 s	10 k	200 k	10 k	200 k	10 k	200 k	10k	200 k	800 M	200 k	800 M	200 k
1 s	20 k	200 k	20 k	200 k	20 k	200 k	20k	200 k	800 M	200 k	800 M	200 k
500 ms	50 k	250 k	50 k	250 k	50 k	250 k	50k	250 k	800 M	250 k	800 M	250 k
200 ms	100 k	200 k	100 k	200 k	100 k	200 k	100k	200 k	800 M	200 k	800 M	200 k
100 ms	200 k	200 k	200 k	200 k	200 k	200 k	200k	200 k	800 M	200 k	800 M	200 k
50 ms	500 k	250 k	500 k	250 k	500 k	250 k	500k	250 k	800 M	250 k	800 M	250 k
20 ms	1 M	200 k	1 M	200 k	1 M	200 k	1M	200 k	800 M	200 k	800 M	200 k
10 ms	2 M	200 k	2 M	200 k	2 M	200 k	2M	200 k	800 M	200 k	800 M	200 k
5 ms	5 M	250 k	5 M	250 k	5 M	250 k	5M	250 k	800 M	250 k	800 M	250 k
2 ms	10 M	200 k	10 M	200 k	10 M	200 k	10M	200 k	800 M	200 k	800 M	200 k
1 ms	20 M	200 k	20 M	200 k	20 M	200 k	20M	200 k	800 M	200 k	800 M	200 k
500 μs	50 M	250 k	50 M	250 k	50 M	250 k	50M	250 k	800 M	250 k	800 M	250 k
200 μs	100 M	200 k	100 M	200 k	100 M	200 k	100M	200 k	800 M	200 k	800 M	200 k
100 μs	200 M	200 k	200 M	200 k	200 M	200 k	200M	200 k	800 M	200 k	800 M	200 k
50 μs	500 M	250 k	500 M	250 k	500 M	250 k	500M	250 k	1 G	250 k	1 G	250 k
20 μs	1 G	200 k	1 G	200 k	1 G	200 k	1G	200 k	Set to normal mode even if envelope mode is specified.			
10 μs	1 G	100 k	2 G	200 k	2 G	200 k	2G	200 k				
5 μs	1 G	50 k	5 G	250 k	2 G	100k	5G	250k				
2 μs	1 G	20 k	10 G	200 k	2 G	40k	10G	200k				
1 μs	1 G	10 k	20 G	200 k	2 G	20k	20G	200k				
500 ns	1 G	5 k	50 G	250 k	2 G	10k	50G	250k				
200 ns	1 G	2 k	100 G	200 k	2 G	4k	100G	200k				
100 ns	1 G	1 k	100 G	100 k	2 G	2k	100G	100k				
50 ns	1 G	500	100 G	50 k	2 G	1k	100G	50k				
20 ns	1 G	200	100 G	20 k	2 G	400	100G	20k				
10 ns	1 G	100	100 G	10 k	2 G	200	100G	10k				
5 ns	100 G	5 k	100 G	5 k	100 G	5 k	100 G	5 k				
2 ns	100 G	2 k	100 G	2 k	100 G	2 k	100 G	2 k				
1 ns	100 G	1 k	100 G	1 k	100 G	1 k	100 G	1 k				

* The values inside the thick frame are for repetitive sampling mode.

Appendix 1 Relationship between the Time Axis Setting, Sample Rate and Record Length

Specified Record Length: 500 kW

Rep: Repetitive sampling mode

Setting T/div	When set to a mode other than envelope mode								When set to envelope mode			
	When interleave mode is OFF				When interleave mode is ON				When interleave mode is OFF		When interleave mode is ON	
	Rep: OFF		Rep: ON		Rep: OFF		Rep: ON		Sample rate (S/s)	Display record length (Word)	Sample rate (S/s)	Display record length (Word)
	Sample rate (S/s)	Display record length (Word)	Sample rate (S/s)	Display record length (Word)	Sample rate (S/s)	Display record length (Word)	Sample rate (S/s)	Display record length (Word)	Sample rate (S/s)	Display record length (Word)	Sample rate (S/s)	Display record length (Word)
50 s	1 k	500 k	1 k	500 k	1 k	500 k	1 k	500 k	800 M	500 k	800 M	500 k
20 s	2 k	400 k	2 k	400 k	2 k	400 k	2 k	400 k	800 M	400 k	800 M	400 k
10 s	5 k	500 k	5 k	500 k	5 k	500 k	5 k	500 k	800 M	500 k	800 M	500 k
5 s	10 k	500 k	10 k	500 k	10 k	500 k	10 k	500 k	800 M	500 k	800 M	500 k
2 s	20 k	400 k	20 k	400 k	20 k	400 k	20 k	400 k	800 M	400 k	800 M	400 k
1 s	50 k	500 k	50 k	500 k	50 k	500 k	50 k	500 k	800 M	500 k	800 M	500 k
500 ms	100 k	500 k	100 k	500 k	100 k	500 k	100 k	500 k	800 M	500 k	800 M	500 k
200 ms	200 k	400 k	200 k	400 k	200 k	400 k	200 k	400 k	800 M	400 k	800 M	400 k
100 ms	500 k	500 k	500 k	500 k	500 k	500 k	500 k	500 k	800 M	500 k	800 M	500 k
50 ms	1 M	500 k	1 M	500 k	1 M	500 k	1 M	500 k	800 M	500 k	800 M	500 k
20 ms	2 M	400 k	2 M	400 k	2 M	400 k	2 M	400 k	800 M	400 k	800 M	400 k
10 ms	5 M	500 k	5 M	500 k	5 M	500 k	5 M	500 k	800 M	500 k	800 M	500 k
5 ms	10 M	500 k	10 M	500 k	10 M	500 k	10 M	500 k	800 M	500 k	800 M	500 k
2 ms	20 M	400 k	20 M	400 k	20 M	400 k	20 M	400 k	800 M	400 k	800 M	400 k
1 ms	50 M	500 k	50 M	500 k	50 M	500 k	50 M	500 k	800 M	500 k	800 M	500 k
500 μs	100 M	500 k	100 M	500 k	100 M	500 k	100 M	500 k	800 M	500 k	800 M	500 k
200 μs	200 M	400 k	200 M	400 k	200 M	400 k	200 M	400 k	800 M	400 k	800 M	400 k
100 μs	500 M	500 k	500 M	500 k	500 M	500 k	500 M	500 k	1 G	500 k	1 G	500 k
50 μs	1 G	500 k	1 G	500 k	1 G	500 k	1 G	500 k	Set to normal mode even if envelope mode is specified.			
20 μs	1 G	200 k	2 G	400 k	2 G	400 k	2 G	400 k				
10 μs	1 G	100 k	5 G	500 k	2 G	200 k	5 G	500 k				
5 μs	1 G	50 k	10 G	500 k	2 G	100 k	10 G	500 k				
2 μs	1 G	20 k	20 G	400 k	2 G	40 k	20 G	400 k				
1 μs	1 G	10 k	50 G	500 k	2 G	20 k	50 G	500 k				
500 ns	1 G	5 k	100 G	500 k	2 G	10 k	100 G	500 k				
200 ns	1 G	2 k	100 G	200 k	2 G	4 k	100 G	200 k				
100 ns	1 G	1 k	100 G	100 k	2 G	2 k	100 G	100 k				
50 ns	1 G	500	100 G	50 k	2 G	1 k	100 G	50 k				
20 ns	1 G	200	100 G	20 k	2 G	400	100 G	20 k				
10 ns	1 G	100	100 G	10 k	2 G	200	100 G	10 k				
5 ns	100 G	5 k	100 G	5 k	100 G	5 k	100 G	5 k				
2 ns	100 G	2 k	100 G	2 k	100 G	2 k	100 G	2 k				
1 ns	100 G	1 k	100 G	1 k	100 G	1 k	100 G	1 k				

* The values inside the thick frame are for repetitive sampling mode.

Appendix 1 Relationship between the Time Axis Setting, Sample Rate and Record Length

Specified Record Length: 1 MW

Rep: Repetitive sampling mode

Setting T/div	When set to a mode other than envelope mode								When set to envelope mode			
	When interleave mode is OFF*2				When interleave mode is ON				When interleave mode is OFF		When interleave mode is ON	
	Rep: OFF		Rep: ON		Rep: OFF		Rep: ON		Sample rate (S/s)	Display record length (Word)	Sample rate (S/s)	Display record length (Word)
	Sample rate (S/s)	Display record length (Word)	Sample rate (S/s)	Display record length (Word)	Sample rate (S/s)	Display record length (Word)	Sample rate (S/s)	Display record length (Word)	Sample rate (S/s)	Display record length (Word)	Sample rate (S/s)	Display record length (Word)
50 s	2 k	1 M	2 k	1 M	2 k	1 M	2 k	1 M	800 M	1 M	800 M	1 M
20 s	5 k	1 M	5 k	1 M	5 k	1 M	5 k	1 M	800 M	1 M	800 M	1 M
10 s	10 k	1 M	10 k	1 M	10 k	1 M	10 k	1 M	800 M	1 M	800 M	1 M
5 s	20 k	1 M	20 k	1 M	20 k	1 M	20 k	1 M	800 M	1 M	800 M	1 M
2 s	50 k	1 M	50 k	1 M	50 k	1 M	50 k	1 M	800 M	1 M	800 M	1 M
1 s	100 k	1 M	100 k	1 M	100 k	1 M	100 k	1 M	800 M	1 M	800 M	1 M
500 ms	200 k	1 M	200 k	1 M	200 k	1 M	200 k	1 M	800 M	1 M	800 M	1 M
200 ms	500 k	1 M	500 k	1 M	500 k	1 M	500 k	1 M	800 M	1 M	800 M	1 M
100 ms	1 M	1 M	1 M	1 M	1 M	1 M	1 M	1 M	800 M	1 M	800 M	1 M
50 ms	2 M	1 M	2 M	1 M	2 M	1 M	2 M	1 M	800 M	1 M	800 M	1 M
20 ms	5 M	1 M	5 M	1 M	5 M	1 M	5 M	1 M	800 M	1 M	800 M	1 M
10 ms	10 M	1 M	10 M	1 M	10 M	1 M	10 M	1 M	800 M	1 M	800 M	1 M
5 ms	20 M	1 M	20 M	1 M	20 M	1 M	20 M	1 M	800 M	1 M	800 M	1 M
2 ms	50 M	1 M	50 M	1 M	50 M	1 M	50 M	1 M	800 M	1 M	800 M	1 M
1 ms	100 M	1 M	100 M	1 M	100 M	1 M	100 M	1 M	800 M	1 M	800 M	1 M
500 μs	200 M	1 M	200 M	1 M	200 M	1 M	200 M	1 M	800 M	1 M	800 M	1 M
200 μs	500 M	1 M	500 M	1 M	500 M	1 M	500 M	1 M	1 G	1 M	1 G	1 M
100 μs	1 G	1 M	1 G	1 M	1 G	1 M	1 G	1 M	Set to normal mode even if envelope mode is specified.			
50 μs	1 G	500 k	2 G	1 M	2 G	1 M	2 G	1 M				
20 μs	1 G	200 k	5 G	1 M	2 G	400 k	5 G	1 M				
10 μs	1 G	100 k	10 G	1 M	2 G	200 k	10 G	1 M				
5 μs	1 G	50 k	20 G	1 M	2 G	100 k	20 G	1 M				
2 μs	1 G	20 k	50 G	1 M	2 G	40 k	50 G	1 M				
1 μs	1 G	10 k	100 G	1 M	2 G	20 k	100 G	1 M				
500 ns	1 G	5 k	100 G	500 k	2 G	10 k	100 G	500 k				
200 ns	1 G	2 k	100 G	200 k	2 G	4 k	100 G	200 k				
100 ns	1 G	1 k	100 G	100 k	2 G	2 k	100 G	100 k				
50 ns	1 G	500	100 G	50 k	2 G	1 k	100 G	50 k				
20 ns	1 G	200	100 G	20 k	2 G	400	100 G	20 k				
10 ns	1 G	100	100 G	10 k	2 G	200	100 G	10 k				
5 ns	100 G	5 k	100 G	5 k	100 G	5 k	100 G	5 k				
2 ns	100 G	2 k	100 G	2 k	100 G	2 k	100 G	2 k				
1 ns	100 G	1 k	100 G	1 k	100 G	1 k	100 G	1 k				

* The values inside the thick frame are for repetitive sampling mode.

Appendix 1 Relationship between the Time Axis Setting, Sample Rate and Record Length

Specified Record Length: 2 MW

Rep: Repetitive sampling mode

Setting T/div	When set to a mode other than envelope mode								When set to envelope mode			
	When interleave mode is OFF ³				When interleave mode is ON				When interleave mode is OFF		When interleave mode is ON	
	Rep: OFF		Rep: ON		Rep: OFF		Rep: ON		Sample rate (S/s)	Display record length (Word)	Sample rate (S/s)	Display record length (Word)
	Sample rate (S/s)	Display record length (Word)	Sample rate (S/s)	Display record length (Word)	Sample rate (S/s)	Display record length (Word)	Sample rate (S/s)	Display record length (Word)	Sample rate (S/s)	Display record length (Word)	Sample rate (S/s)	Display record length (Word)
50 s	5 k	2.5 M ²	5 k	2.5 M ²	5 k	2.5 M ²	5 k	2.5 M ²	800 M	2.5 M ²	800 M	2.5 M ²
20 s	10 k	2 M	10 k	2 M	10 k	2 M	10 k	2 M	800 M	2 M	800 M	2 M
10 s	20 k	2 M	20 k	2 M	20 k	2 M	20 k	2 M	800 M	2 M	800 M	2 M
5 s	50 k	2.5 M ²	50 k	2.5 M ²	50 k	2.5 M ²	50 k	2.5 M ²	800 M	2.5 M ²	800 M	2.5 M ²
2 s	100 k	2 M	100 k	2 M	100 k	2 M	100 k	2 M	800 M	2 M	800 M	2 M
1 s	200 k	2 M	200 k	2 M	200 k	2 M	200 k	2 M	800 M	2 M	800 M	2 M
500 ms	500 k	2.5 M ²	500 k	2.5 M ²	500 k	2.5 M ²	500 k	2.5 M ²	800 M	2.5 M ²	800 M	2.5 M ²
200 ms	1 M	2 M	1 M	2 M	1 M	2 M	1 M	2 M	800 M	2 M	800 M	2 M
100 ms	2 M	2 M	2 M	2 M	2 M	2 M	2 M	2 M	800 M	2 M	800 M	2 M
50 ms	5 M	2.5 M ²	5 M	2.5 M ²	5 M	2.5 M ²	5 M	2.5 M ²	800 M	2.5 M ²	800 M	2.5 M ²
20 ms	10 M	2 M	10 M	2 M	10 M	2 M	10 M	2 M	800 M	2 M	800 M	2 M
10 ms	20 M	2 M	20 M	2 M	20 M	2 M	20 M	2 M	800 M	2 M	800 M	2 M
5 ms	50 M	2.5 M ²	50 M	2.5 M ²	50 M	2.5 M ²	50 M	2.5 M ²	800 M	2.5 M ²	800 M	2.5 M ²
2 ms	100 M	2 M	100 M	2 M	100 M	2 M	100 M	2 M	800 M	2 M	800 M	2 M
1 ms	200 M	2 M	200 M	2 M	200 M	2 M	200 M	2 M	800 M	2 M	800 M	2 M
500 μs	500 M	2.5 M ²	500 M	2.5 M ²	500 M	2.5 M ²	500 M	2.5 M ²	1 G	2.5 M ²	1 G	2.5 M ²
200 μs	1 G	2 M	1 G	2 M	1 G	2 M	1 G	2 M	Set to normal mode even if envelope mode is specified.			
100 μs	1 G	1 M	2 G	2 M	2 G	2 M	2 G	2 M				
50 μs	1 G	500 k	5 G	2.5 M ²	2 G	1 M	5 G	2.5 M ²				
20 μs	1 G	200 k	10 G	2 M	2 G	400 k	10 G	2 M				
10 μs	1 G	100 k	20 G	2 M	2 G	200 k	20 G	2 M				
5 μs	1 G	50 k	50 G	2.5 M ²	2 G	100 k	50 G	2.5 M ²				
2 μs	1 G	20 k	100 G	2 M	2 G	40 k	100 G	2 M				
1 μs	1 G	10 k	100 G	1 M	2 G	20 k	100 G	1 M				
500 ns	1 G	5 k	100 G	500 k	2 G	10 k	100 G	500 k				
200 ns	1 G	2 k	100 G	200 k	2 G	4 k	100 G	200 k				
100 ns	1 G	1 k	100 G	100 k	2 G	2 k	100 G	100 k				
50 ns	1 G	500	100 G	50 k	2 G	1 k	100 G	50 k				
20 ns	1 G	200	100 G	20 k	2 G	400	100 G	20 k				
10 ns	1 G	100	100 G	10 k	2 G	200	100 G	10 k				
5 ns	100 G	5 k	100 G	5 k	100 G	5 k	100 G	5 k				
2 ns	100 G	2 k	100 G	2 k	100 G	2 k	100 G	2 k				
1 ns	100 G	1 k	100 G	1 k	100 G	1 k	100 G	1 k				

1 The values inside the thick frame are for repetitive sampling mode.

2 Since the number of data points acquired is 2 MW, only 8 divisions of the waveform is displayed along the time axis. In addition, the trigger position in this case is set by taking 8 divisions as 100%.

3 On the 4 MW memory model, box average cannot be performed.

Appendix 1 Relationship between the Time Axis Setting, Sample Rate and Record Length

Specified Record Length: 4 MW⁴

Rep: Repetitive sampling mode

Setting T/div	When set to a mode other than envelope mode								When set to envelope mode			
	When interleave mode is OFF				When interleave mode is ON				When interleave mode is OFF		When interleave mode is ON	
	Rep: OFF		Rep: ON		Rep: OFF		Rep: ON		Sample rate (S/s)	Display record length (Word)	Sample rate (S/s)	Display record length (Word)
	Sample rate (S/s)	Display record length (Word)	Sample rate (S/s)	Display record length (Word)	Sample rate (S/s)	Display record length (Word)	Sample rate (S/s)	Display record length (Word)	Sample rate (S/s)	Display record length (Word)	Sample rate (S/s)	Display record length (Word)
50 s	10 k	5 M ²	10 k	5 M ²	10 k	5 M ²	10 k	5 M ²	800 M	5 M ²	800 M	5 M ²
20 s	20 k	4 M	20 k	4 M	20 k	4 M	20 k	4 M	800 M	4 M	800 M	4 M
10 s	50 k	5 M ²	50 k	5 M ²	50 k	5 M ²	50 k	5 M ²	800 M	5 M ²	800 M	5 M ²
5 s	100 k	5 M ²	100 k	5 M ²	100 k	5 M ²	100 k	5 M ²	800 M	5 M ²	800 M	5 M ²
2 s	200 k	4 M	200 k	4 M	200 k	4 M	200 k	4 M	800 M	4 M	800 M	4 M
1 s	500 k	5 M ²	500 k	5 M ²	500 k	5 M ²	500 k	5 M ²	800 M	5 M ²	800 M	5 M ²
500 ms	1 M	5 M ²	1 M	5 M ²	1 M	5 M ²	1 M	5 M ²	800 M	5 M ²	800 M	5 M ²
200 ms	2 M	4 M	2 M	4 M	2 M	4 M	2 M	4 M	800 M	4 M	800 M	4 M
100 ms	5 M	5 M ²	5 M	5 M ²	5 M	5 M ²	5 M	5 M ²	800 M	5 M ²	800 M	5 M ²
50 ms	10 M	5 M ²	10 M	5 M ²	10 M	5 M ²	10 M	5 M ²	800 M	5 M ²	800 M	5 M ²
20 ms	20 M	4 M	20 M	4 M	20 M	4 M	20 M	4 M	800 M	4 M	800 M	4 M
10 ms	50 M	5 M ²	50 M	5 M ²	50 M	5 M ²	50 M	5 M ²	800 M	5 M ²	800 M	5 M ²
5 ms	100 M	5 M ²	100 M	5 M ²	100 M	5 M ²	100 M	5 M ²	800 M	5 M ²	800 M	5 M ²
2 ms	200 M	4 M	200 M	4 M	200 M	4 M	200 M	4 M	800 M	4 M	800 M	4 M
1 ms	500 M	5 M ²	500 M	5 M ²	500 M	5 M ²	500 M	5 M ²	1 G	5 M ²	1 G	5 M ²
500 μs	1 G	5 M ²	1 G	5 M ²	1 G	5 M ²	1 G	5 M ²	Set to normal mode even if envelope mode is specified.			
200 μs	1 G	2 M	2 G	4 M	2 G	4 M	2 G	4 M				
100 μs	1 G	1 M	5 G	5 M ²	2 G	2 M	5 G	5 M ²				
50 μs	1 G	500 k	10 G	5 M ²	2 G	1 M	10 G	5 M ²				
20 μs	1 G	200 k	20 G	4 M	2 G	400 k	20 G	4 M				
10 μs	1 G	100 k	50 G	5 M ²	2 G	200 k	50 G	5 M ²				
5 μs	1 G	50 k	100 G	5 M ²	2 G	100 k	100 G	5 M ²				
2 μs	1 G	20 k	100 G	2 M	2 G	40 k	100 G	2 M				
1 μs	1 G	10 k	100 G	1 M	2 G	20 k	100 G	1 M				
500 ns	1 G	5 k	100 G	500 k	2 G	10 k	100 G	500 k				
200 ns	1 G	2 k	100 G	200 k	2 G	4 k	100 G	200 k				
100 ns	1 G	1 k	100 G	100 k	2 G	2 k	100 G	100 k				
50 ns	1 G	500	100 G	50 k	2 G	1 k	100 G	50 k				
20 ns	1 G	200	100 G	20 k	2 G	400	100 G	20 k				
10 ns	1 G	100	100 G	10 k	2 G	200	100 G	10 k				
5 ns	100 G	5 k	100 G	5 k	100 G	5 k	100 G	5 k				
2 ns	100 G	2 k	100 G	2 k	100 G	2 k	100 G	2 k				
1 ns	100 G	1 k	100 G	1 k	100 G	1 k	100 G	1 k				

- 1 The values inside the thick frame are for repetitive sampling mode.
- 2 Since the number of data points acquired is 4 MW, only 8 divisions of the waveform is displayed along the time axis. In addition, the trigger position in this case is set by taking 8 divisions as 100%.
- 3 On the 4 MW model, box average cannot be performed.
- 4 This record length cannot be specified on the 4 MW memory model when interleave mode is OFF.

Appendix 1 Relationship between the Time Axis Setting, Sample Rate and Record Length

Specified Record Length: 8 MW⁴

Rep: Repetitive sampling mode

Setting T/div	When set to a mode other than envelope mode								When set to envelope mode			
	When interleave mode is OFF ³				When interleave mode is ON				When interleave mode is OFF		When interleave mode is ON	
	Rep: OFF		Rep: ON		Rep: OFF		Rep: ON		Sample rate (S/s)	Display record length (Word)	Sample rate (S/s)	Display record length (Word)
	Sample rate (S/s)	Display record length (Word)	Sample rate (S/s)	Display record length (Word)	Sample rate (S/s)	Display record length (Word)	Sample rate (S/s)	Display record length (Word)	Sample rate (S/s)	Display record length (Word)	Sample rate (S/s)	Display record length (Word)
50 s	20 k	10 M ²	20 k	10 M ²	20 k	10 M ²	20 k	10 M ²	800 M	10 M ²	800 M	10 M ²
20 s	50 k	10 M ²	50 k	10 M ²	50 k	10 M ²	50 k	10 M ²	800 M	10 M ²	800 M	10 M ²
10 s	100 k	10 M ²	100 k	10 M ²	100 k	10 M ²	100 k	10 M ²	800 M	10 M ²	800 M	10 M ²
5 s	200 k	10 M ²	200 k	10 M ²	200 k	10 M ²	200 k	10 M ²	800 M	10 M ²	800 M	10 M ²
2 s	500 k	10 M ²	500 k	10 M ²	500 k	10 M ²	500 k	10 M ²	800 M	10 M ²	800 M	10 M ²
1 s	1 M	10 M ²	1 M	10 M ²	1 M	10 M ²	1 M	10 M ²	800 M	10 M ²	800 M	10 M ²
500 ms	2 M	10 M ²	2 M	10 M ²	2 M	10 M ²	2 M	10 M ²	800 M	10 M ²	800 M	10 M ²
200 ms	5 M	10 M ²	5 M	10 M ²	5 M	10 M ²	5 M	10 M ²	800 M	10 M ²	800 M	10 M ²
100 ms	10 M	10 M ²	10 M	10 M ²	10 M	10 M ²	10 M	10 M ²	800 M	10 M ²	800 M	10 M ²
50 ms	20 M	10 M ²	20 M	10 M ²	20 M	10 M ²	20 M	10 M ²	800 M	10 M ²	800 M	10 M ²
20 ms	50 M	10 M ²	50 M	10 M ²	50 M	10 M ²	50 M	10 M ²	800 M	10 M ²	800 M	10 M ²
10 ms	100 M	10 M ²	100 M	10 M ²	100 M	10 M ²	100 M	10 M ²	800 M	10 M ²	800 M	10 M ²
5 ms	200 M	10 M ²	200 M	10 M ²	200 M	10 M ²	200 M	10 M ²	800 M	10 M ²	800 M	10 M ²
2 ms	500 M	10 M ²	500 M	10 M ²	500 M	10 M ²	500 M	10 M ²	1 G	10 M ²	1 G	10 M ²
1 ms	1 G	10 M ²	1 G	10 M ²	1 G	10 M ²	1 G	10 M ²				
500 μs	1 G	5 M	2 G	10 M ²	2 G	10 M ²	2 G	10 M ²				
200 μs	1 G	2 M	5 G	10 M ²	2 G	4 M	5 G	10 M ²				
100 μs	1 G	1 M	10 G	10 M ²	2 G	2 M	10 G	10 M ²				
50 μs	1 G	500 k	20 G	10 M ²	2 G	1 M	20 G	10 M ²				
20 μs	1 G	200 k	50 G	10 M ²	2 G	400 k	50 G	10 M ²				
10 μs	1 G	100 k	100 G	10 M ²	2 G	200 k	100 G	10 M ²				
5 μs	1 G	50 k	100 G	5 M	2 G	100 k	100 G	5 M				
2 μs	1 G	20 k	100 G	2 M	2 G	40 k	100 G	2 M				
1 μs	1 G	10 k	100 G	1 M	2 G	20 k	100 G	1 M				
500 ns	1 G	5 k	100 G	500 k	2 G	10 k	100 G	500 k				
200 ns	1 G	2 k	100 G	200 k	2 G	4 k	100 G	200 k				
100 ns	1 G	1 k	100 G	100 k	2 G	2 k	100 G	100 k				
50 ns	1 G	500	100 G	50 k	2 G	1 k	100 G	50 k				
20 ns	1 G	200	100 G	20 k	2 G	400	100 G	20 k				
10 ns	1 G	100	100 G	10 k	2 G	200	100 G	10 k				
5 ns	100 G	5 k	100 G	5 k	100 G	5 k	100 G	5 k				
2 ns	100 G	2 k	100 G	2 k	100 G	2 k	100 G	2 k				
1 ns	100 G	1 k	100 G	1 k	100 G	1 k	100 G	1 k				

¹

- 1 The values inside the thick frame are for repetitive sampling mode.
- 2 Since the number of data points acquired is 8 MW, only 8 divisions of the waveform is displayed along the time axis. In addition, the trigger position in this case is set by taking 8 divisions as 100%.
- 3 Box average, averaging (simple average), and computation cannot be performed.
- 4 This record length cannot be specified on the 4 MW memory model.

Appendix 1 Relationship between the Time Axis Setting, Sample Rate and Record Length

Specified Record Length: 16 MW⁴

Rep: Repetitive sampling mode

Setting T/div	When set to a mode other than envelope mode								When set to envelope mode			
	When interleave mode is OFF ³				When interleave mode is ON				When interleave mode is OFF		When interleave mode is ON	
	Rep: OFF		Rep: ON		Rep: OFF		Rep: ON		Sample rate (S/s)	Display record length (Word)	Sample rate (S/s)	Display record length (Word)
	Sample rate (S/s)	Display record length (Word)	Sample rate (S/s)	Display record length (Word)	Sample rate (S/s)	Display record length (Word)	Sample rate (S/s)	Display record length (Word)	Sample rate (S/s)	Display record length (Word)	Sample rate (S/s)	Display record length (Word)
50 s	This record length cannot be used when interleave mode is OFF.				50 k	25 M ²	Repetitive sampling mode cannot be turned ON at this record length setting.		This record length cannot be used when interleave mode is OFF.		800 M	25 M ²
20 s					100 k	20 M ²					800 M	20 M ²
10 s					200 k	20 M ²					800 M	20 M ²
5 s					500 k	25 M ²					800 M	25 M ²
2 s					1 M	20 M ²					800 M	20 M ²
1 s					2 M	20 M ²					800 M	20 M ²
500 ms					5 M	25 M ²					800 M	25 M ²
200 ms					10 M	20 M ²					800 M	20 M ²
100 ms					20 M	20 M ²					800 M	20 M ²
50 ms					50 M	25 M ²					800 M	25 M ²
20 ms					100 M	20 M ²					800 M	20 M ²
10 ms					200 M	20 M ²					800 M	20 M ²
5 ms					500 M	25 M ²					1 G	25 M ²
2 ms					1 G	20 M ²					Set to normal mode even if envelope mode is specified.	
1 ms					2 G	20 M ²						
500 μs					2 G	10 M						
200 μs					2 G	4 M						
100 μs					2 G	2 M						
50 μs					2 G	1 M						
20 μs					2 G	400 k						
10 μs	2 G	200 k										
5 μs	2 G	100 k										
2 μs	2 G	40 k										
1 μs	2 G	20 k										
500 ns	2 G	10 k										
200 ns	2 G	4 k										
100 ns	2 G	2 k										
50 ns	2 G	1 k										
20 ns	2 G	400										
10 ns	2 G	200										
5 ns	100 G	5 k										
2 ns	100 G	2 k										
1 ns	100 G	1 k	1									

- 1 The values inside the thick frame are for repetitive sampling mode.
- 2 The number of data points that is acquired is 16 MW. Therefore, if the display record length is 20 MW, only 8 divisions of the waveform is displayed; if the display record length is 25 MW, only 6.4 divisions of the waveform is displayed. In addition, the trigger positions in these cases are set by taking 8 divisions or 6.4 divisions as 100%.
- 3 Box average, averaging (simple average), and computation cannot be performed.
- 4 This record length cannot be specified on the 4 MW memory model.

Appendix 2 How to Calculate the Area of a Waveform

Int1TY

Total Area for Positive Side Only: S_1+S_2

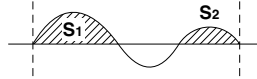

Int2TY

Total Area for both Positive and Negative Sides: $S_1+S_3-S_2$

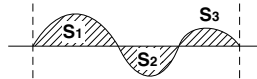

Int1XY

(1) Multiple Loops

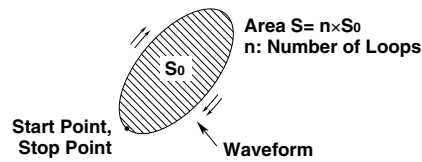

(2) Non-Closed Curve

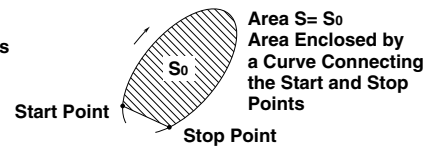

(3) Loop Tracing a Figure-Eight

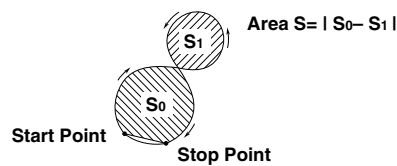

(4) Spiral Loop

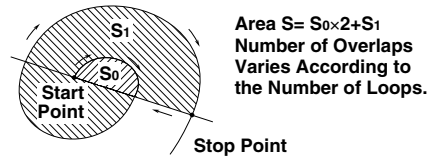

Int2XY

(1) When Only One Y Data Corresponds to X Data

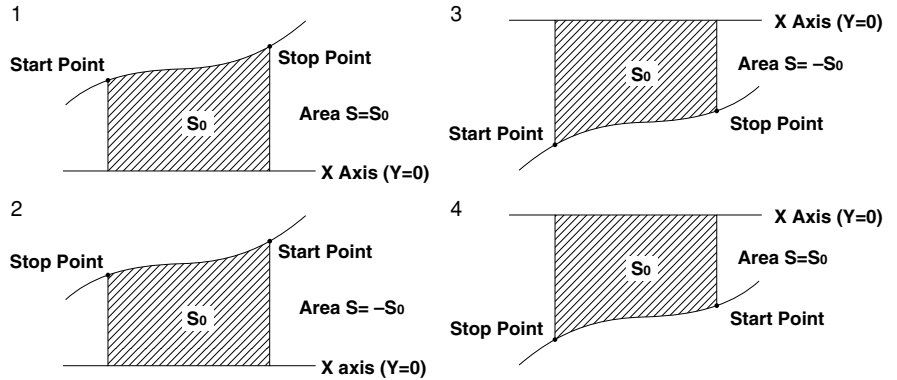

(2) When the Waveform Extends into the Negative Side

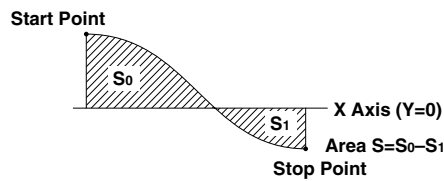

(3) When Two or more Y Data Correspond to X Data

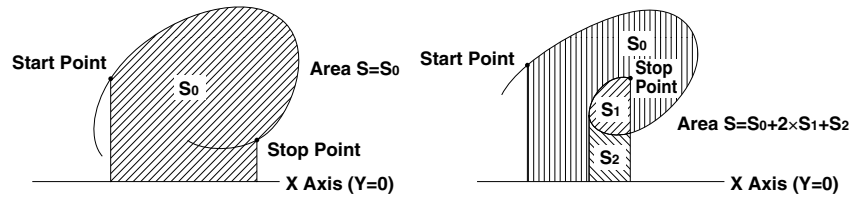

Appendix 3 ASCII Header File Format

//YOKOGAWA ASCII FILE FORMAT

\$PublicInfo

FormatVersion 1.11
Model DL7440
Endian Big
DataFormat Trace
GroupNumber 2
TraceTotalNumber 6
DataOffset 0

\$Group1

TraceNumber 4
BlockNumber 1
TraceName CH1 CH2 CH3 CH4
BlockSize 1002 1002 1002 1002
VResolution 1.5625000E+00 1.5625000E+00 1.5625000E+00 1.5625000E+00
VOffset 0.0000000E+00 0.0000000E+00 0.0000000E+00 0.0000000E+00
VDataType IS2 IS2 IS2 IS2
VUnit V V A V
VPlusOverData 32768 32768 32768 32768
VMinusOverData -32769 -32769 -32769 -32769
VIllegalData -32769 -32769 -32769 -32769
VMaxData 32767 32767 32767 32767
VMinData -32768 -32768 -32768 -32768
HResolution 5.0000000E-09 5.0000000E-09 5.0000000E-09 5.0000000E-09
HOffset -2.5000000E-06 -2.5000000E-06 -2.5000000E-06 -2.5000000E-06
HUnit s s s s
Date 2003/01/25 2003/01/25 2003/01/25 2003/01/25
Time 01:45:00.00 01:45:00.00 01:45:00.00 01:45:00.00

```

$Group2
TraceNumber      2
BlockNumber      1
TraceName        MATH1          MATH2
BlockSize        1002          1002
VResolution      6.1035156E-03  1.2207031E+00
VOffset          -7.7000000E+01 2.0000000E+04
VDataType        IS2           IS2
VUnit            DB            V
VPlusOverData    32768          32768
VMinusOverData   -32769         -32769
VIllegalData     -32769         -32769
VMaxData         32767          32767
VMinData         -32768         -32768
HResolution      2.0000000E-01  5.0000000E-09
HOffset          0.0000000E+00 -2.5000000E-06
HUnit            Hz            s
Date             2003/01/25     2003/01/25
Time             01:45:00     01:45:00

$PrivateInfo
ModelVersion     1.01
DisplayBlockSize 1002          1002          1002          1002
DisplayPointNo.  1            1            1            1
PhaseShift       0            0            0            0
PTraceName       CH1          CH2          CH3          CH4    MATH1    MATH2

```

(Note) The header file is a common file used by YOKOGAWA's measuring instruments. Therefore, data that is not required by the DL7400 (0s) is also included.

\$PublicInfo (Common Information)

FormatVersion: Header file version number (common to YOKOGAWA's header files)
Model: Model name
Endian: Endian mode when saving data (Big/Ltl)¹
DataFormat: Storage format of the binary waveform data (Trace/Block)²
GroupNumber: The number of "\$Group"s indicated below
TraceTotalNumber: Total number of selected waveforms
DataOffset: Start position of the binary waveform data³

\$Group1 (Group Information)

TraceNumber: Number of waveforms in this group
BlockNumber: Number of blocks in this group⁴
TraceName: Name of each waveform
BlockSize: Number of data points in a single block of each waveform
VResolution: Value of coefficient VResolution of the Y-axis conversion equation of each waveform⁵
VOffset: Value of coefficient VOffset of the Y-axis conversion equation of each waveform⁵
VDataType: Type of binary file waveform data for each waveform⁶
VUnit: Unit used on the Y-axis of each waveform (no effect on the data)
VPlusOverData: Error data when the binary data of each waveform is greater than or equal to this value
VMinusOverData: Error data when the binary data of each waveform is less than or equal to this value
VMaxData: Maximum value of binary data for each waveform
VMinData: Minimum value of binary data for each waveform
HResolution: Value of coefficient HResolution of the X-axis conversion equation of each waveform⁷
HOffset: Value of coefficient HOffset of the X-axis conversion equation of each waveform⁷
HUnit: Unit used on the X-axis of each waveform (no effect on the data)
Date: Date when waveform acquisition was completed
Time: Time when waveform acquisition was completed
For details on 1 to 7, see the next page.

\$PrivateInfo (Model-Specific Information)

ModelVersion: Version number of the instrument
DisplayBlockSize: Length of the data displayed on the screen (display record length)
DisplayPointNo.: Value indicating the memory position (nth point in the memory) corresponding the left end of the display record length. (display offset, 1 when the specified record length = display record length)
PhaseShift: Phase information (lead: -, delay: +)
PTraceName: Name of each waveform

* Actual display offset of the phase-shifted waveform = DisplayPointNo. – PhaseShift

Creation of ASCII Header File

When waveform data (Waveform) is stored to a floppy disk, the following two files will be created automatically in the DL_WAVE directory.

- Waveform display data file (*.wvf)
- ASCII header file (*.hdr)

The waveform data file can be recalled to the instrument using the FILE menu. The ASCII header files explained here cannot be viewed on the DL7400. Use the data such as when analyzing the waveforms on your PC.

1 Endian mode when saving data

Big: Motorola 68000-family data

Ltl: Intel 86 family data

2 Storage format of the binary waveform data

Trace: Groups into blocks, each block for a single waveform.

Block: Groups into blocks, each block for a given time interval.

The DL7400 supports only the Trace format.

3 Binary file start position

Offset from the beginning of the file

4 Maximum number of blocks in the group

Maximum number of blocks applies if the number of blocks varies between waveforms.

5 Y axis conversion equation for each waveform

Y-axis value = VResolution × raw data + VOffset

6 Data type

ISn: n-byte signed integer

IUn: n-byte unsigned integer

FSn: n-byte signed real number

FUn: n-byte unsigned real number

Bm: m-bit data

7 X axis conversion equation for each waveform

X axis value = HResolution × (Data No. – 1) + HOffset

Appendix 4 User-Defined Computation

Digital Filter

Type

Type	Bandwidth
Gauss	Low-pass
Sharp	Low-pass, high-pass, and band-pass
IIR (Butterworth)	Low-pass, high-pass, and band-pass

Filter Order

See the following table for the filter orders

		2%	5%	10%	20%	30% (Cutoff*)
Gauss	Low-pass	49	21	9	5	5
Sharp	Low-pass	88	36	18	9	8
	High-pass	159	65	33	17	13
IIR	Low-pass	4	4	4	3	2
	High-pass	4	4	4	4	3

* The cutoff percentage is with respect to the sample rate.

Filter Characteristics

Filter	Pass-band Ripple	Attenuation Slope	Attenuation at the Stop-band	Phase
Gauss	0 dB	*	–	Linear phase
Sharp	±0.3 dB	–40 dB per octave (low-pass),	–40 dB	Linear phase
		–40 dB per octave (high-pass)		
IIR	0 dB	–5 dB per 1/6 octave (low-pass),	–	Not linear phase
		–20 dB per octave (high-pass)		

* For Gaussian filter : $-3.0 \times (f/f_c)^2$ dB (f : frequency, f_c : cutoff frequency)

Frequency Characteristics of Filters

f: Frequency (Hz)

Gauss (Cutoff 10%)

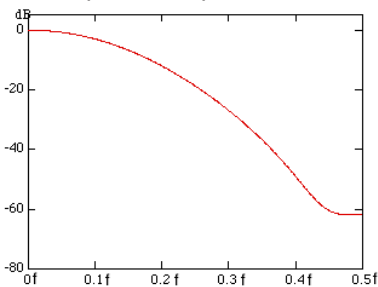

Sharp (Low Pass, Cutoff 10%)

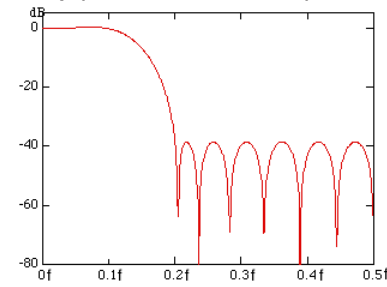

IIR (Low Pass, Cutoff 10%)

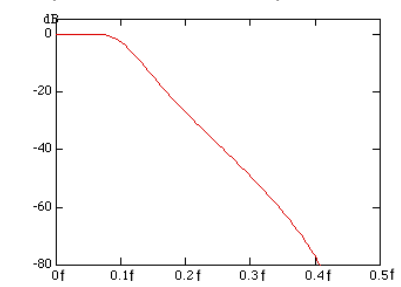

Note

The higher the filter order the longer it takes for computation.

Hilbert Function (HLBT)

Normally, when we analyze a real time signal, it is convenient to think of this signal as the real part of a complex function and do the actual analysis using the complex function. If the real time signal is considered to be the real part of the function, the imaginary part can be determined with the Hilbert transform of the real part. The Hilbert transform does not change the order of the individual variables. Hilbert transform of a time signal results in another time signal. The Hilbert transform is described below. When transforming a signal in the time domain, the signal is transformed into the frequency domain, first, using the Fourier transform. Next, the phase of each frequency component is shifted by -90 deg if the frequency is positive and $+90$ deg if negative. Lastly, taking the inverse Fourier transform completes the Hilbert transform.

Example

- Hilbert transform can be used to analyze an envelope waveform.
 AM (amplitude modulation): $\text{SQRT}(C1 \times C1 + \text{HLBT}(C1) \times \text{HLBT}(C1))$
 Demodulation of a FM signal: $\text{DIF}(\text{PH}(C1, \text{HLBT}(C1)))$

Phase Function (PH)

Phase function $\text{PH}(X1, Y1)$ computes $\tan^{-1}(X1/Y1)$. However, the phase function takes the phase of the previous point into consideration and continues to sum even when the value exceeds $\pm\pi$ (ATAN function reflects at $\pm\pi$). The unit is radians.

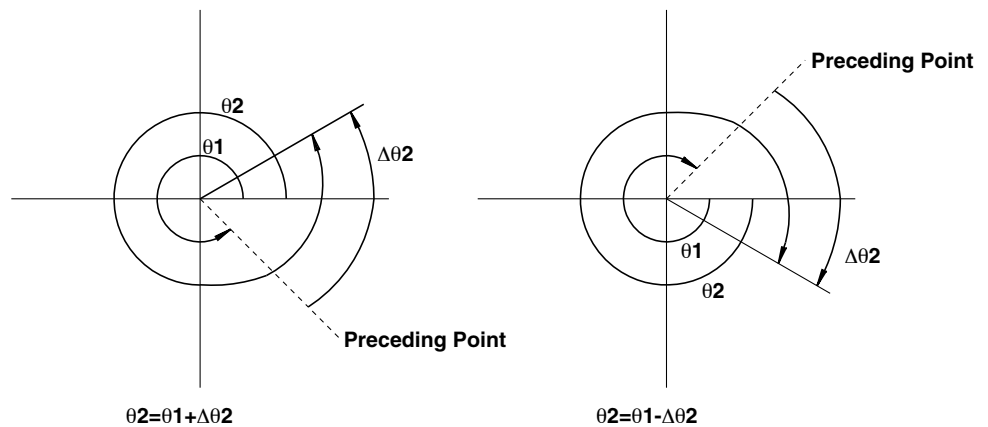

Differentiation and Integration (DIF, DDIF, INTG, and IINTG)

Differentiation (DIF, DDIF)

The computation of the first order and second order differentiation uses the 5th order Lagrange interpolation formula to derive a point of data from the 5 points around the point. The figure below shows data f_0 to f_n with respect to sampling time x_0 to x_n . The derivative and integrated value corresponding to these data points are computed as follows:

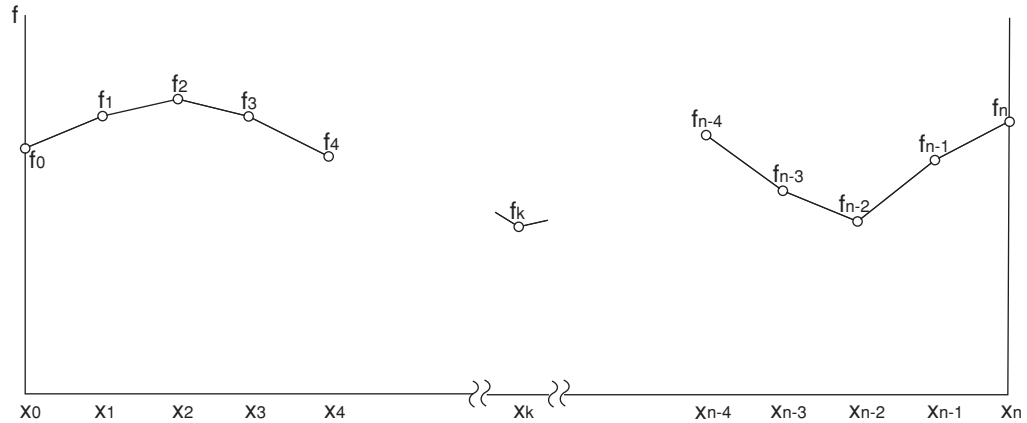

• **Equation for First Order Derivative (DIF)**

Point x_0 $f_0' = \frac{1}{12h} [-25f_0 + 48f_1 - 36f_2 + 16f_3 - 3f_4]$
 Point x_1 $f_1' = \frac{1}{12h} [-3f_0 - 10f_1 + 18f_2 - 6f_3 + f_4]$
 Point x_2 $f_2' = \frac{1}{12h} [f_0 - 8f_1 + 8f_3 - f_4]$
 Point x_k $f_k' = \frac{1}{12h} [f_{k-2} - 8f_{k-1} + 8f_{k+1} - f_{k+2}]$
 Point x_{n-2} $f_{n-2}' = \frac{1}{12h} [f_{n-4} - 8f_{n-3} + 8f_{n-1} - f_n]$
 Point x_{n-1} $f_{n-1}' = \frac{1}{12h} [-f_{n-4} + 6f_{n-3} - 18f_{n-2} + 10f_{n-1} + 3f_n]$
 Point x_n $f_n' = \frac{1}{12h} [3f_{n-4} - 16f_{n-3} + 36f_{n-2} - 48f_{n-1} + 25f_n]$

$h = \Delta x$ is the sampling interval (sec) (example $h = 200 \times 10^{-6}$ at 5 kHz)

• **Equation for Second Order Derivative (DDIF)**

Point x_0 $f_0'' = \frac{1}{12h^2} [35f_0 - 104f_1 + 114f_2 - 56f_3 + 11f_4]$
 Point x_1 $f_1'' = \frac{1}{12h^2} [11f_0 - 20f_1 + 6f_2 + 4f_3 - f_4]$
 Point x_2 $f_2'' = \frac{1}{12h^2} [-f_0 + 16f_1 - 30f_2 + 16f_3 - f_4]$
 Point x_k $f_k'' = \frac{1}{12h^2} [-f_{k-2} + 16f_{k-1} - 30f_k + 16f_{k+2} - f_{k+2}]$
 Point x_{n-2} $f_{n-2}'' = \frac{1}{12h^2} [-f_{n-4} + 16f_{n-3} - 30f_{n-2} + 16f_{n-1} - f_n]$
 Point x_{n-1} $f_{n-1}'' = \frac{1}{12h^2} [-f_{n-4} + 4f_{n-3} + 6f_{n-2} - 20f_{n-1} + 11f_n]$
 Point x_n $f_n'' = \frac{1}{12h^2} [11f_{n-4} - 56f_{n-3} + 114f_{n-2} - 104f_{n-1} + 35f_n]$

Integration (INTG, IINTG)

The first and second order integrated values are derived using the trapezoidal rule.

- **Equation for First Order Integration (INTG)**

Point x_0 $l_0 = 0$

Point x_1 $l_1 = \frac{1}{2} (f_0 + f_1)h$

Point x_2 $l_2 = \frac{1}{2} (f_0 + f_1)h + \frac{1}{2} (f_1 + f_2)h = l_1 + \frac{1}{2} (f_1 + f_2)h$

Point x_n $l_n = l_{n-1} + \frac{1}{2} (f_{n-1} + f_n)h$

- **Equation for Second Order Integration (IINTG)**

Point x_0 $ll_0 = 0$

Point x_1 $ll_1 = \frac{1}{2} (l_0 + l_1)h$

Point x_2 $ll_2 = \frac{1}{2} (l_0 + l_1)h + \frac{1}{2} (l_1 + l_2)h = ll_1 + \frac{1}{2} (l_1 + l_2)h$

Point x_n $ll_n = ll_{n-1} + \frac{1}{2} (l_{n-1} + l_n)h$

Binary Computation (BIN)

Performs binary computation using the specified threshold levels. For the procedure in setting the threshold level, see section 9.3, "Binary Computation."

BIN(C1)

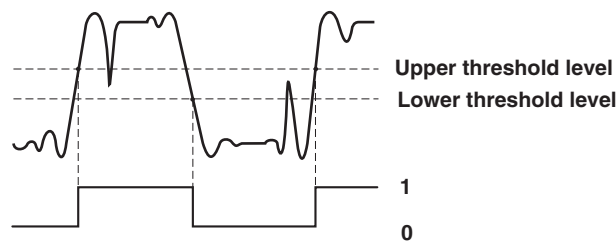

Pulse Width Computation

The signal is converted to binary values by comparing to a preset threshold level, and the time of the pulse width is plotted as the Y-axis value for that interval. The following 8 intervals are available.

- PWHH: From the rising edge to the next rising edge.
- PWHL: From the rising edge to the next falling edge.
- PWLH: From the falling edge to the next rising edge.
- PWLL: From the falling edge to the next falling edge.
- PWXX: From the rising or falling edge to the next rising or falling edge.
- FV: Inverse of PWHH
- DUTYH: Positive (high) duty cycle within each cycle of the specified waveform
- DUTYL: Negative (low) duty cycle within each cycle of the specified waveform

Example 1 When the Interval Is Set to PWHH

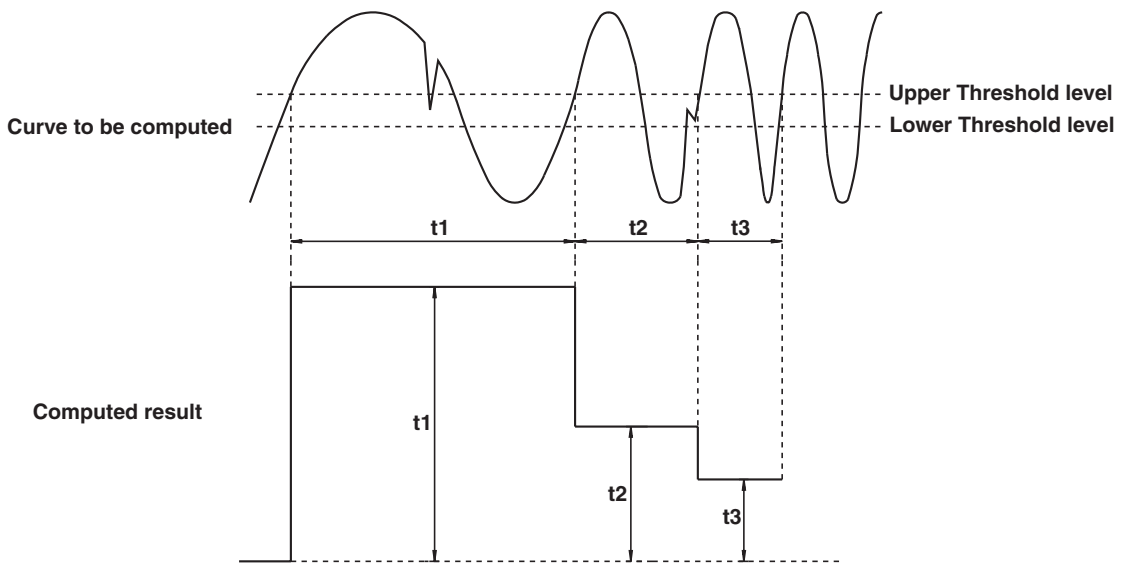

Example 2 When the Interval Is Set to DUTYH

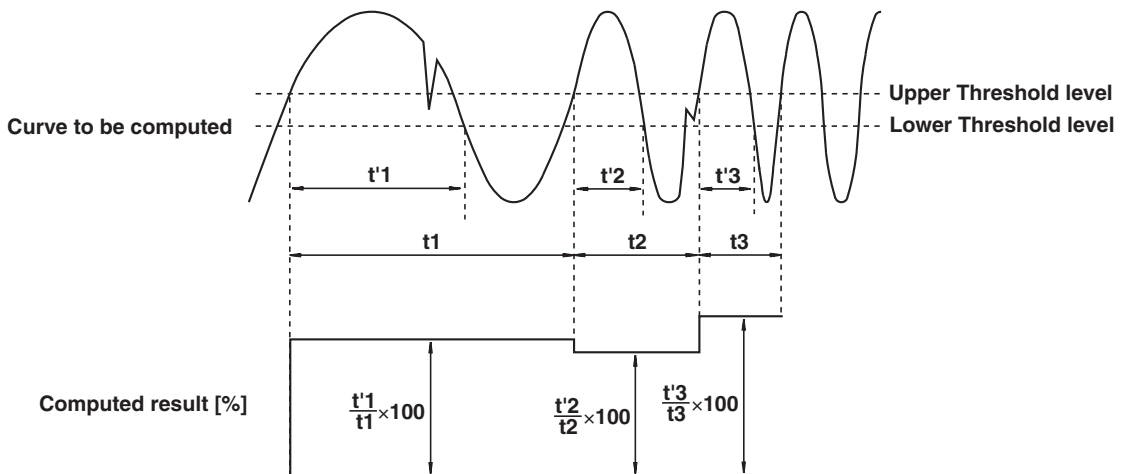

FFT Function

Each frequency component G of a linear spectrum is represented by $G=R+jI$ (R : real part, I : imaginary part).

Linear Spectrum

Linear spectrum is a spectrum that can be directly determined with the FFT. The magnitude and phase of each frequency component included in the measured waveform can be found. The power spectrum and cross spectrum can also be determined from one or two linear spectrums. Because the FFT is a complex function, the linear spectrum produces the real part and imaginary part of the frequency components. The magnitude and phase of the linear spectrum can also be determined from the result. The following spectrums can be determined with this instrument.

Item	Equation	Computation
Real part	LS-REAL	R
Imaginary part	LS-IMAG	I
Amplitude	LS-MAG	$\sqrt{R^2 + I^2}$
Log magnitude	LS-LOGMAG	$20 \times \log \sqrt{R^2 + I^2}$
Phase	LS-PHASE	$\tan^{-1}(I/R)$

Log magnitude reference (0 dB): 1 Vpeak

Power Spectrum

Power spectrum expresses the power (squared value) of each frequency component included in the measured signal. It is determined by taking the product of the linear spectrum and its complex conjugate. It does not contain phase information. The following spectrums can be determined with this instrument.

Item	Equation	Computation
Amplitude	PS-MAG	DC component R^2+I^2
		AC component $(R^2+I^2)/2$
Log magnitude	PS-LOGMAG	DC component $10 \times \log(R^2+I^2)$
		AC component $10 \times \log\{(R^2+I^2)/2\}$

Log magnitude reference (0 dB): 1 Vrms²

Power Spectrum Density

Power spectrum density expresses the power spectrum per unit frequency. It is determined by dividing the power spectrum by the frequency resolution Δf found during the analysis of the power spectrum. The computation varies depending on the window function. Power spectrum density is used to compare power spectrums analyzed at different frequency bands. However, it is not necessary for signals having a line spectrum such as sine waves. The following spectrums can be determined with this instrument.

Item	Equation	Computation
Amplitude	PSD-MAG	PS-MAG/ Δf (for rectangular window)
		PS-MAG/ $1.5\Delta f$ (for Hanning window)
Log magnitude	PSD-LOGMAG	$10 \times \log \text{PS-MAG}/\Delta f$ (for rectangular window)
		$10 \times \log \text{PS-MAG}/1.5\Delta f$ (for Hanning window)

Log magnitude reference (0 dB): 1 Vrms²

Cross Spectrum

Cross spectrum is determined from 2 signals. It is found by taking the product of the linear spectrum of one signal (G_y) and the complex conjugate (G_x^*) of the linear spectrum of the other signal (G_x). If the linear spectrums of the 2 signals are represented by

$$G_x = R_x + jI_x$$

$$G_y = R_y + jI_y$$

then the cross spectrum G_{yx} is

$$G_{yx} = G_y \times G_x^* = (R_y + jI_y)(R_x - jI_x) = R_{yx} + jI_{yx}$$

$$\text{where } R_{yx} = R_y R_x + I_y I_x$$

$$I_{yx} = R_x I_y - R_y I_x$$

The following spectrums can be determined with this instrument.

Item	Equation	Computation
Real part	CS-REAL	DC component $R_{yx}/$
		AC component $R_{yx}/2$
Imaginary part	CS-IMAG	DC component I_{yx}
		AC component $I_{yx}/2$
Amplitude	CS-MAG	DC component $\sqrt{(R_{yx}^2 + I_{yx}^2)}$
		AC component $\sqrt{(R_{yx}^2 + I_{yx}^2)}/2$
Log magnitude	CS-LOGMAG	DC component $10 \times \log \sqrt{(R_{yx}^2 + I_{yx}^2)}$
		AC component $10 \times \log (\sqrt{(R_{yx}^2 + I_{yx}^2)}/2)$
Phase	CS-PHASE	$\tan^{-1}(I_{yx}/R_{yx})$

Transfer Function

The transfer function expresses the frequency characteristics between the input to the transfer system and the output. The transfer function is determined by the ratio of the output linear spectrum (G_y) and the input linear spectrum (G_x) at each frequency. Also, as can be seen from the next equation, the transfer function can be defined as the ratio of the cross spectrum of the input and output (G_{yx}) and the input power spectrum (G_{xx}).

$$\text{Transfer Function} = G_y/G_x = (G_y \times G_x^*) / (G_x \times G_x^*) = G_{yx}/G_{xx} = (R_{yx} + jI_{yx}) / (R_x^2 + I_x^2)$$

The following items can be determined with this instrument.

Item	Equation	Computation
Real part	TF-REAL	$R_{yx}/(R_x^2 + I_x^2)$
Imaginary part	TF-IMAG	$I_{yx}/(R_x^2 + I_x^2)$
Amplitude	TF-MAG	$\sqrt{(R_{yx}^2 + I_{yx}^2)} / (R_x^2 + I_x^2)$
Log magnitude	TF-LOGMAG	$20 \times \log \sqrt{(R_{yx}^2 + I_{yx}^2)} / (R_x^2 + I_x^2)$
Phase	TF-PHASE	$\tan^{-1}(I_{yx}/R_{yx})$

The magnitude of the transfer function shows the ratio of the magnitudes of the output linear spectrum and the input linear spectrum while the phase shows the phase difference of the two.

Coherence Function

This expresses the ratio of the output power generated with the input signal to the transfer system and the total output power.

$$\text{Coherence function} = G_{yx} \times G_{yx}^* / (G_{xx} \times G_{yy})$$

Item	Equation	Computation
Amplitude	CH-MAG	$(R_{yx}^2 + I_{yx}^2) / (G_{xx} \times G_{yy})$

If the output signal is due entirely to the input signal, the coherence function becomes 1. As the ratio decreases, it falls below 1. Thus, the coherence function always takes on a value between 0 and 1.

Note

On one data acquisition, the coherence function becomes 1 across all frequencies. Also, make sure to take the frequency average of the computation.

Time Windows

You can select rectangular, Hanning, or flattop for the time window. The rectangular window is best suited to transient signals, such as impulse waves, which attenuate completely within the time window. The Hanning and flattop windows allow continuity of the signal by gradually attenuating the parts of the signal located near the ends of the time window down to the 0 level. Hence, it is best suited to continuous signals. With the Hanning window, the frequency resolution is relatively high as compared with the flattop window. However, the flattop window has a higher level of accuracy. When the waveform being analyzed is a continuous signal, consider the above characteristics in selecting the proper window to be applied.

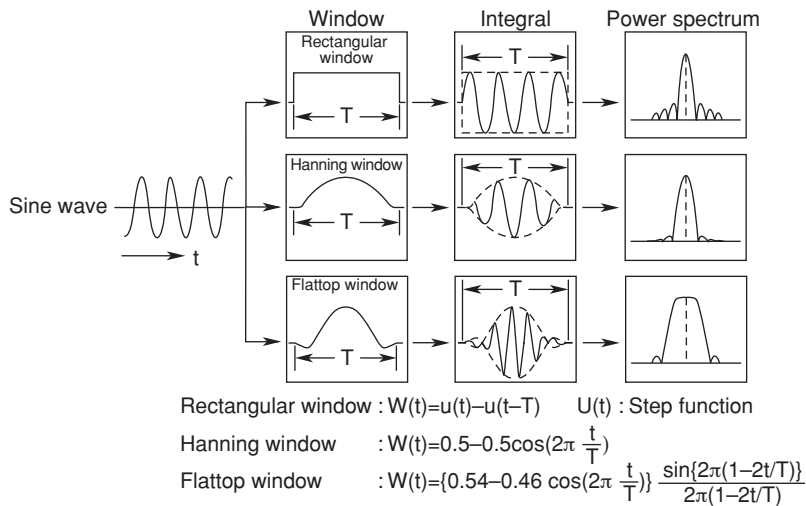

Notes When Executing the FFT Computation

Normally, computation is performed on the sampled data stored in the acquisition memory. However, for waveforms that have been acquired in envelope mode, computation is performed on the maximum/minimum values per acquisition interval.

Appendix 5 List of Default Settings

The initial settings may differ depending on installed options. Be sure to check your instrument's specifications before referring to the list.

Key	Soft Key	Default Setting	Key	Soft Key	Default Setting
CH1 to 8			HISTORY		
	Display	ON		Select Record	0
	Position	0.00 div		Display Mode	One
	Coupling	DC1M Ω		Start Record	0
	Probe	10:1		End Record	Oldest number
	Offset	0 V		Show Map No.	1
	Band Width	Full		Search Mode	OFF
	Variable	50 V	ZOOM		
	Linear Scale	OFF		Mode	Main
	Label	Channel name	SEARCH		
V/div				Type	Edge
		50 V/div		Z1 Mag	$\times 2$
LOGIC				Z1 Position	0.000div
	Mode	OFF	DISPLAY		
	Select	POD A		Format	Quad
	Type	CMOS (5V)		Interpolation	Sine
	Level	2.5 V		Graticule	Grid
T/div				Scale Value	OFF
		1 ms/s		Trace Label	OFF
PRESET				Accumulate	OFF
	Select	All		Translucent	OFF
	Type	CMOS (5V)		Mapping	Auto
	Probe	10:1	X-Y		
	V/div	2.00 V		Mode	T-Y
	Offset	0.00 V	FILE		
	Trig Level	2.50 V		File Item	Setup
MODE			MEASURE		
	Mode	Auto		Mode	OFF
SIMPLE				Item Setup	
	Source	CH1			Source CH1
	Level	0.0 V			Item OFF
	Slope	Rising edge		Delay Setup	
	Coupling	DC			Source CH1
	HF Reject	OFF			Mode OFF
	Hysteresis	Smaller of the two settings		1 cycle mode	OFF
	Hold Off	0.08 μ s		Time range1	-5.000 div
POSITON				Time range2	5.000 div
	Position	50%		Trace	CH1
DELAY				Dist/Prox Mode	%
	Delay	0.0 μ s		Distal	90%
ACTION				Mesial	50%
	Buzzer	OFF		Proximal	10%
	Save to File	OFF		High/Low Mode	Auto
	Hard Copy	OFF	CURSOR		
	Image Save	OFF		Type	OFF
	Send Mail	OFF	GO/NO-GO		
	Mail Count	100		Mode	OFF
	ACQ Count	Infinite	MATH		
ACQ				Math1 Display	OFF
	Record Length	10 k		Math1 Setup	C1+C2
	Mode	Normal		Math1 Label	Math1
	Count	Infinite		Math2 Display	OFF
	Interleave	OFF		Math2 Setup	C3+C4
	Repetitive	OFF		Math2 Label	Math2
	Time Base	Int			

Key	Soft Key	Default Setting
PHASE		
	Mode	OFF
PRINT MENU		
	Print to	Built-In
	Format	Normal
	Information	OFF
IMAGE SAVE MENU		
	Format	TIFF
	Color	OFF
	File Name	0000

Appendix 6 Key Assignments of the USB Keyboard

104 Keyboard (US)

Key	When Pressed with the Control Key		When the Soft Keyboard Is Displayed		Other	
		+Shift*		+Shift*		+Shift*
a	ACQ menu	Same as left	a	A		
b	MATH menu	Same as left	b	B		
c	Execute COPY	Same as left	c	C		
d	DISPLAY menu	Same as left	d	D		
e	ENHANCED menu	Same as left	e	E		
f	FILE menu	Same as left	f	F		
g	GO/NOGO menu	Same as left	g	G		
h	HISTORY menu	Same as left	h	H		
i	Execute IMAGE SAVE	Same as left	i	I		
j	PRESET menu	Same as left	j	J		
k			k	K		
l	LOGIC menu	Same as left	l	L		
m	MEASURE menu	Same as left	m	M		
n			n	N		
o			o	O		
p	POSITION menu	Same as left	p	P		
q	Execute CLEAR TRACE	Same as left	q	Q		
r	Execute RESET	Same as left	r	R		
s	SHIFT condition	Same as left	s	S		
t	TRIGMODE menu	Same as left	t	T		
u	CURSOR menu	Same as left	u	U		
v			v	V		
w	SIMPLE menu	Same as left	w	W		
x			x	X		
y			y	Y		
z	ZOOM menu	Same as left	z	Z		
1	CH1 menu		1	!		
2	CH2 menu		2	@		
3	CH3 menu		3	#		
4	CH4 menu		4	\$		
5	CH5 menu		5	%		
6	CH6 menu		6	^		
7	CH7 menu		7	&		
8	CH8 menu		8	*		
9			9	(
0			0)		
Enter	Return(Enter),Select	Same as left	Return(Enter)	Same as left	Return(Enter)	Same as left
Esc	Escape	Same as left	Escape	Same as left	Escape	Same as left
Back Space			Back Space	Same as left		
Tab						
Space Bar			Space Bar	Same as left		
-			-	_		
=			=	+		
[[{		
]]	}		
\	SETUP	Same as left	\			
;			;	:		
'			'	"		
,			,	<		
.			.	>		
/	MISC menu	Execute HELP	/	?		
Caps Lock			Caps Lock	Same as left		

Appendix 6 Key Assignments of the USB Keyboard

F1	Select soft key1	Same as left	Select soft key1	Same as left	Select soft key1	Same as left
F2	Select soft key2	Same as left	Select soft key2	Same as left	Select soft key2	Same as left
F3	Select soft key3	Same as left	Select soft key3	Same as left	Select soft key3	Same as left
F4	Select soft key4	Same as left	Select soft key4	Same as left	Select soft key4	Same as left
F5	Select soft key5	Same as left	Select soft key5	Same as left	Select soft key5	Same as left
F6	Select soft key6	Same as left	Select soft key6	Same as left	Select soft key6	Same as left
F7	Select soft key7	Same as left	Select soft key7	Same as left	Select soft key7	Same as left
F8	Escape	Same as left	Escape	Same as left	Escape	Same as left
F9						
F10						
F11			μ	Same as left		
F12	START/STOP	Same as left	Ω	Same as left	START/STOP	Same as left
Print Screen	Execute COPY	Same as left				
Scroll Lock	Execute IMAGE SAVE	Same as left				
Pause	Execute SNAPSHOT	Same as left				
Insert			Insert condition	Same as left		
Home	Decrement V/Div	Same as left			Decrement V/Div	Same as left
Page Up	Decrement T/Div	Same as left			Decrement T/Div	Same as left
Delete			Delete	Same as left		
End	Increment V/Div	Same as left			Increment V/Div	Same as left
Page Down	Increment T/Div	Same as left			Increment T/Div	Same as left
→	Cursor to the right	Same as left	Cursor to the right	Same as left	Cursor to the right	Same as left
←	Cursor to the left	Same as left	Cursor to the left	Same as left	Cursor to the left	Same as left
↓	Jog shuttle down	Same as left	Select soft key6	Same as left	Jog shuttle down	Same as left
↑	Jog shuttle up	Same as left	Select soft key6	Same as left	Jog shuttle up	Same as left
(Numeric)						
Num Lock						
/			/	Same as left		
*	START/STOP	Same as left	*	Same as left	START/STOP	Same as left
-			-	Same as left		
+			+	Same as left		
Enter			Return(Enter)	Same as left	Return(Enter),Select	Same as left
1	CH1 menu	Increment V/Div	1			Increment V/Div
2	CH2 menu	Jog shuttle down	2			Jog shuttle down
3	CH3 menu	Increment T/Div	3			Increment T/Div
4	CH4 menu	Cursor to the left	4			Cursor to the left
5	CH5 menu		5			
6	CH6 menu	Cursor to the right	6			Cursor to the right
7	CH7 menu	Decrement V/Div	7			Decrement V/Div
8	CH8 menu	Jog shuttle up	8			Jog shuttle up
9		Decrement T/Div	9			Decrement T/Div
0			0	Insert condition		
.			.	DELETE		

* The operation of the key when holding down the Shift key on the USB keyboard.

Appendix 6 Key Assignments of the USB Keyboard

109 Keyboard (Japanese)

Key	When Pressed with the Control Key		When the Soft Keyboard Is Displayed		Other	
		+Shift*		+Shift*		+Shift*
a	ACQ menu	Same as left	a	A		
b	MATH menu	Same as left	b	B		
c	Execute COPY	Same as left	c	C		
d	DISPLAY menu	Same as left	d	D		
e	ENHANCED menu	Same as left	e	E		
f	FILE menu	Same as left	f	F		
g	GO/NOGO menu	Same as left	g	G		
h	HISTORY menu	Same as left	h	H		
i	Execute IMAGE SAVE	Same as left	i	I		
j	PRESET menu	Same as left	j	J		
k			k	K		
l	LOGIC menu	Same as left	l	L		
m	MEASURE menu	Same as left	m	M		
n			n	N		
o			o	O		
p	POSITION menu	Same as left	p	P		
q	Execute CLEAR TRACE	Same as left	q	Q		
r	Execute RESET	Same as left	r	R		
s	SHIFT condition	Same as left	s	S		
t	TRIGMODE menu	Same as left	t	T		
u	CURSOR menu	Same as left	u	U		
v			v	V		
w	SIMPLE menu	Same as left	w	W		
x			x	X		
y			y	Y		
z	ZOOM menu	Same as left	z	Z		
1	CH1 menu		1	!		
2	CH2 menu		2	"		
3	CH3 menu		3	#		
4	CH4 menu		4	\$		
5	CH5 menu		5	%		
6	CH6 menu		6	&		
7	CH7 menu		7	'		
8	CH8 menu		8	(
9			9)		
0			0			
Enter	Return(Enter), Select	Same as left	Return(Enter)	Same as left	Return(Enter)	Same as left
Esc	Escape	Same as left	Escape	Same as left	Escape	Same as left
Back Space			Back Space	Same as left		
Tab						
Space Bar			Space Bar	Same as left		
-			-	=		
^			^	~		
@			@	`		
[[{		
;			;	+		
:			:	*		
]]	}		
,			,	<		
.			.	>		
/	MISC menu	Execute HELP	/	?		
Caps Lock			Caps Lock	Same as left		

Appendix 6 Key Assignments of the USB Keyboard

F1	Select soft key1	Same as left	Select soft key1	Same as left	Select soft key1	Same as left
F2	Select soft key2	Same as left	Select soft key2	Same as left	Select soft key2	Same as left
F3	Select soft key3	Same as left	Select soft key3	Same as left	Select soft key3	Same as left
F4	Select soft key4	Same as left	Select soft key4	Same as left	Select soft key4	Same as left
F5	Select soft key5	Same as left	Select soft key5	Same as left	Select soft key5	Same as left
F6	Select soft key6	Same as left	Select soft key6	Same as left	Select soft key6	Same as left
F7	Select soft key7	Same as left	Select soft key7	Same as left	Select soft key7	Same as left
F8	Escape	Same as left	Escape	Same as left	Escape	Same as left
F9						
F10						
F11			μ	Same as left		
F12	START/STOP	Same as left	Ω	Same as left	START/STOP	Same as left
Print Screen	Execute COPY	Same as left				
Scroll Lock	Execute IMAGE SAVE	Same as left				
Pause	Execute SNAPSHOT	Same as left				
Insert			Insert condition	Same as left		
Home	Decrement V/Div	Same as left			Decrement V/Div	Same as left
Page Up	Decrement T/Div	Same as left			Decrement T/Div	Same as left
Delete			Delete	Same as left		
End	Increment V/Div	Same as left			Increment V/Div	Same as left
Page Down	Increment T/Div	Same as left			Increment T/Div	Same as left
→	Cursor to the right	Same as left	Cursor to the right	Same as left	Cursor to the right	Same as left
←	Cursor to the left	Same as left	Cursor to the left	Same as left	Cursor to the left	Same as left
↓	Jog shuttle down	Same as left	Select soft key6	Same as left	Jog shuttle down	Same as left
↑	Jog shuttle up	Same as left	Select soft key6	Same as left	Jog shuttle up	Same as left
\	SETUP menu	Same as left	\			
\			\	-		
(Numeric)						
Num Lock						
/			/	Same as left		
*	START/STOP	Same as left	*	Same as left	START/STOP	Same as left
-			-	Same as left		
+			+	Same as left		
Enter			Return(Enter)	Same as left	Return(Enter),Select	Same as left
1	CH1 menu	Increment V/Div	1			Increment V/Div
2	CH2 menu	Jog shuttle down	2			Jog shuttle down
3	CH3 menu	Increment T/Div	3			Increment T/Div
4	CH4 menu	Cursor to the left	4			Cursor to the left
5	CH5 menu		5			
6	CH6 menu	Cursor to the right	6			Cursor to the right
7	CH7 menu	Decrement V/Div	7			Decrement V/Div
8	CH8 menu	Jog shuttle up	8			Jog shuttle up
9		Decrement T/Div	9			Decrement T/Div
0			0	Insert condition		
.			.	DELETE		

* The operation of the key when holding down the Shift key on the USB keyboard.

Index

Symbols

-	9-3
*	9-3
+	9-3
.BMP	12-37
.BTD	12-42
.CSV	12-25, 12-32
.FLD	12-25
.JPG	12-37
.JTD	12-42
.NTD	12-42
.PNG	12-37
.PS	12-37
.PTD	12-42
.SET	12-18
.SNP	12-30
.TIF	12-37
.TTD	12-42
.TXT	12-34
.WVF	12-25
1 Cycle Mode	10-52
1 division	2-2
104 keyboard	App-28
109 keyboard	App-30
16 MW memory model	ii
1Cycle Mode	10-48
24-hour clock	3-14
4 MW memory model	ii
400 MHz passive probe	iv

A

A	2-4
A Delay B	6-18
A Delay B trigger	2-9, 6-18
A->B(N) trigger	2-9, 6-15
AC1MΩ	2-3
accessories	iii
Accumulate	8-6, 8-7
accumulated display	2-18
accumulation time	8-7
accuracy test	16-10
ACQ	1-5
ACQ Count	6-44, 10-69, 10-73
acquisition count	7-9, 7-10
acquisition memory	2-1
acquisition mode	2-15
ACTION	1-4, 6-44
Action	10-69, 10-73
action count	6-45
action mail	13-13
action-on-trigger	2-14
Active High	6-47
Active Low	6-47
addition, subtraction, and multiplication	2-21, 9-4
additional information	11-5
aliasing	2-6
All	10-3
All Set	12-45
Allocation	8-9
ambient humidity	3-4
ambient temperature	3-4
analysis numbers	10-85

analysis reference point	10-84
Analyze Setup	10-76
AND	10-14, 10-70, 10-74
angle cursor	2-29, 10-41
anonymous	13-8
Area	10-62
area, calculation of	App-12
arrow keys	4-3
ASCII	12-25
ASCII header file format	App-14
Attached Image File	13-12
attenuation constant	2-16
attenuation ratio	2-3
Attr	12-43
Auto	8-3, 9-4, 10-49
auto calibration	4-20
auto level mode	2-12, 6-2
auto mode	2-12, 6-2
auto naming	12-18
Auto Off	15-6
Auto Scroll	10-23, 10-25
auto scroll direction	10-32
auto scroll search	2-28, 10-32
auto setup	2-34, 4-17
automated measurement mode	10-50
automated measurement of waveform parameters	2-30, 10-50
automated measurement of waveform parameters on dual areas	2-31, 10-64
auxiliary I/O	14-1
auxiliary I/O section	17-8
Average	9-23
average computation	9-27
average count	2-16
Average Domain	9-27
Average Weight	9-27
averaging	2-16
averaging mode	2-16, 7-7
Avq	10-59

B

backlight	15-7
BandPass	9-27
Bandwidth	5-14
bandwidth limit	2-4, 5-14
battery life	3-6
battery replacement	3-6
BIN	App-21
Bin	9-6, 10-80
Binary	12-25
binary computation	2-21, 9-7, App-21
bit	5-19
bit data, read direction of	10-42
block diagram	2-1
Both	8-3
box average	2-16, 7-8
Brightness	15-6
broadcasting type	2-11, 6-38
Built-in	11-3
built-in printer	1-2, 17-7
built-in storage media drive	ii, 1-1
Buzzer	6-45, 10-71

Index

C

Calibration 4-19, 4-20
calibration period, recommended 17-10
capture 13-29
Center 6-35, 9-4
chip select signal 10-83
Clear Pattern 10-19
CLEAR TRACE 1-5
Clear Trace 2-20, 8-15
Click Sound 15-1
Clock CH 6-21
clock channel 6-23, 10-26, 10-29
clock signal 10-82
Cnt 10-59
coherence function App-25
Color 8-7, 11-7, 11-10, 11-12, 11-13, 12-35, 12-37
color grade mode 8-7
combining of bit data 10-43
command area 13-36
comment 12-18
commercial power supply 6-14
communication port 13-19
communication using commands 2-32
Compression 12-35, 12-37
computation end point 9-26
computation mode 9-2
computation range 9-26
computation start point 9-13, 9-26
computed points, number of 9-13
computed waveform label 9-2
computed waveforms 2-21, 9-2
computer interface 17-9
Condition 6-15, 6-17, 6-18, 6-22, 6-26, 10-6, 10-11, 10-69
Confirmation 13-31
Connect Log List 13-17
Constant 9-22, 9-27
Continue 10-71
Control Script 13-35
cooling method 17-10
Copy 12-47, 12-49
Count 7-6
Coupling 5-6, 6-10
cross spectrum App-24
CS 10-77, 10-86
current probe iv
current-to-voltage conversion ratio 2-3
CURSOR 1-4
cursor measurements 2-29, 10-41
cutoff frequency 9-27
cycle 9-23
cycle average 2-23, 9-28
Cycle Count 9-28
Cycle Statistics 10-55

D

Data Byte 10-80
Data Capture 13-27
data compression 12-26
data control 13-29
data format 12-37
data length 10-87
data number 13-33
data points, number of 2-15
data, saving of 2-35
Data Search 10-80
data size 12-18, 12-25, 12-30, 12-32
data to be analyzed 10-83

Data Type 12-21, 12-25
Data1 10-85
Data1 (CH2) 10-77
Data2 10-85
Data2 (CH3) 10-77
date 3-14
Date/Time 3-13
date/time, automatic setting of 3-14
daylight savings time 13-42
DC1M Ω 2-3
DC50 Ω 2-3
DDIF App-20
Default Gateway 13-5
default values App-26
Degree 10-39, 10-52
DELAY 1-4
Delay 6-5, 6-19, 6-20
Delay Setup 10-47
Delay Time 2-9
Deskew 4-21
Dest Dir 12-48
Destination 12-29
Detail 10-80
detailed list 10-87
detection count 10-26, 10-32, 10-52
detection point 10-52
determination logic 10-70, 10-74
determination operation 10-71
determination parameter 10-74
determination pattern 10-87
determination range 10-71
determination status 10-29
determination time 6-29, 10-31
determination type 6-28, 10-30
determination zones 10-70
Device 13-21
Device List 15-2
DHCP 13-3, 13-5
DIF App-20
Diff 9-10
differentiation 2-21, 9-11, App-20
digital filter 9-27, App-18
Dir Name 12-52
Direction 10-24
DISPLAY 1-4
display 1-6, 17-4
display color 15-5
display format 2-18, 8-3, 8-11
display format (cursor measurements, logic) 10-42
display interpolation 2-18
Display Mode 8-14, 10-1, 10-3
display record length 2-5
displayed parameters, number of 10-50
Distal 10-49, 10-53
divided windows, number of 8-3
DL7400 environment 13-20
DL7440 ii
DL7480 ii
DNS 13-4, 13-6
DNS Server 13-4
Domain Suffix 13-4, 13-6
drive test 16-10
Dual 8-3
Dual Area 10-61

E

Edge 10-15
 edge search 2-26, 10-25
 edge trigger 2-8
 Edit 10-67
 email transmission 2-33
 emission 17-11
 Enable State 10-78
 enable status 10-84
 End Point 9-20
 End Record 10-1
 ENG 15-1
 ENHANCED 1-4
 enhanced trigger 2-9
 Enter 6-17
 envelope mode 2-16, 7-7
 error messages 16-2
 Ether 13-43
 Ethernet 13-1
 Ethernet interface 13-1
 Ethernet port 1-1
 execution error 16-3
 Exit 6-17
 Exp 9-23
 exponent of 10 9-25
 exponential averaging 2-16, 2-23, 7-7, 9-27
 Ext 6-12
 EXT CLOCK IN 14-1
 EXT TRIG IN 14-1
 extension 12-18, 12-25, 12-30, 12-32, 12-34, 12-37
 external clock input 14-1
 external clock input terminal 1-1
 external clock signal 5-21
 external dimensions 17-12
 external trigger 6-12
 external trigger input 14-1
 external trigger input terminal 1-1

F

FET probe iv
 FFT 2-22, 9-13, 9-26
 FFT function App-23
 FFT Setup 9-21
 Field 6-37
 field number 6-38
 FILE 1-5
 file attribute 12-45
 file name 12-18
 Filter 9-21
 filter type 9-27
 first order derivative App-20
 first order integration App-21
 Fit Meas Range 8-10
 Fixed 8-3
 Flattop 2-22, 9-14
 Float 12-25
 floppy disk 12-3
 Format 8-1, 8-2, 11-3, 11-7, 11-11, 12-35, 12-39
 formatting disks 12-13
 Frame Pattern 10-87
 Frame Skip 6-38, 6-40
 FREE 11-2
 free software 2-35
 frequency bandwidth 5-14
 frequency characteristics 5-7
 frequency characteristics (smoothing) 9-5

front panel 1-1
 FTP client 2-32, 13-8
 FTP passive mode 13-45
 FTP server 2-33, 13-8, 13-10, 13-16
 FTP server function 13-26
 Function 12-41, 17-4
 functional ground terminal 1-1

G

Gate Way 13-4
 general specifications 17-10
 GMT (Greenwich Mean Time) 13-42
 GND 2-3
 GO/NO GO 1-4
 GO/NO-GO determination 2-31, 10-70
 GO/NO-GO parameter determination 10-74
 grade width 8-7
 Graphic Color 15-4
 Graticule 2-20, 8-16
 Greenwich Mean Time 13-42
 grid 2-2
 ground level mark 1-6
 ground terminal v
 guide 11-2

H

H 6-17
 handle 1-2
 handling precautions 3-1
 Hanning 2-22, 9-14
 Hard Copy 6-45, 10-71
 HELP 1-5
 help window 4-23
 Hex 10-80
 Hexa 8-3
 HF Reject 6-10
 HF rejection 2-14, 6-11, 6-17
 High 10-49
 HighPass 9-27
 Hilbert function App-19
 HISTORY 1-5
 History 12-21
 history map 10-3
 history memory 2-17
 history search 2-25, 10-5, 10-10
 History Statistics 10-58
 history waveforms 2-17, 2-25, 10-3
 history waveforms, statistical processing of 2-31
 HLBT App-19
 HOLD 11-2
 Hold Off 2-14, 6-6, 6-8
 Horizontal 10-33
 horizontal axis 2-5
 horizontal cursor 2-29, 10-41
 Hour 3-14
 Hysteresis 2-14, 6-10, 6-11, 6-17

I

I/O data bits, read direction of 10-84
 ID number 12-8
 IEEE802.3 13-1
 IINTG App-21
 Image 12-41
 IMAGE SAVE 1-5

Index

Image Save 6-45, 10-71
immunity 17-11
IN 6-34, 10-8, 10-13
indefinite data 10-86
Indefinite State 10-87
Infinite 10-71
Information 11-4, 13-39
initialization 2-34, 4-15
Initialize SCSI 12-8
inlet holes 1-2
input coupling 2-3, 5-7
input section 17-1
input terminal (external auxiliary signal) 14-1
installation conditions 3-3
installation position 3-4
instrument control 13-30
instrument information 13-39
instrument number iii
insulation resistance 17-10
Integ 9-10
integration 2-21, 9-11, App-21
integration start point 9-11
Intensity 15-5
Interleave 7-3
interleave mode 2-15, 7-3
internal memory 13-19
internal processing indication 1-6
Interpolation 8-4
interpolation off 2-18
Interval 13-12, 13-33
INTG App-21
inversion 2-21
Invert 9-8
IP Address 13-4, 13-5

J

jog shuttle & SELECT vii, 4-2, 4-3
JPN 15-1

K

Key Board 16-9
key operations, basic 4-1
Key test 16-10
Keyboard 4-4, 15-2
keyboard interface 17-8
keyboard language 4-6
keys 1-3
knobs 1-3

L

L 6-17
Label 5-18, 8-18
LCD 15-6
leap years 3-14
Left 10-7
Level 2-8, 6-9
Level/Coupling 6-16
Line 6-14, 6-37, 8-5
line number 6-39
linear 9-23
Linear Count 9-27
linear interpolation 2-18
Linear Scale 5-15
linear scaling 2-4, 5-16

Link 13-40
Lissajous waveform 2-19
List 10-79
list display 10-60
lithium battery 3-6
lock release lever 11-2
Log 13-37
LOGIC 1-3
Logic 6-41, 10-12
logic input 5-19
logic input section 17-2
logic probe iv, 3-11
logic probe input connector 1-1
logic signal input 2-4
logic signals, displaying of 2-18
logic trigger 2-12, 6-41
logic waveform display frame 1-7
Login Name 13-8, 13-10
long print 11-5
long print, output example 11-5
Low 10-49
Lower 10-7, 10-12
LowPass 9-27
LPR client 2-32, 13-11
LPR server 13-11
LPR Time Out 13-44, 13-45
LSB first 10-78

M

MAC address 13-43
Mag 11-3
Magnification 11-5
mail 13-13
Mail Address 13-12, 13-13
Mail Server 13-12, 13-13
Mail Setup 13-12
MailBaseTime 13-12, 13-13
malfunction 16-1
MAN FEED 11-2
Manual 9-4, 10-78
Mapping 8-1
Marker 10-37
marker cursor 2-29, 10-41
MATH 1-4
Math Mode 9-1
Math1 Display 9-1
Math1 Label 9-2
MAX-MIN 10-49
MEASURE 1-4
Measure 12-31
Measure Parameter List 10-56
measured values, number of displayed 13-33
measurement and statistical processing of history 10-60
measurement mode 10-52
measurement parameters 10-50, 10-51, 10-64
measurement per cycle and statistical processing
 within the measurement range 2-30, 10-60
measurement range 13-33
measurement range (dual areas) 10-65
measurement range (waveform parameters) 10-53
measurement resolution 2-2
Measurement Trend 13-32
measurement trend of waveform parameters 13-32
Media Info 12-12
media information 12-14
memory test 16-10

MENU 1-5
 Mesial 10-49, 10-53
 message language 15-1
 messages 15-1, 16-2
 MISC 1-5
 MODE 1-4
 MODEL ii
 movable holder 11-2
 movement range of cursors 10-42
 moving average 7-8
 MSB first 10-78

N

Neg 6-38
 Net Drive Setup 13-8
 Net Mask 13-4
 Net Print 11-11
 Net Print Setup 13-11
 network drive 2-32, 13-10, 13-46, 13-47
 network printer 2-32, 11-11, 13-11
 New 10-66
 Next 10-81
 No. iii
 normal mode 2-12, 2-15, 6-2, 7-7
 notation system 10-42, 10-87
 number of data points 2-15
 number of times pattern is met 6-17

O

Octal 8-3
 Offset 5-9
 Offset Cancel 2-4
 Offset Cancel Mode 15-3
 offset voltage 2-4, 5-9
 Only 8-3
 OPEN 11-2
 operating altitude 17-10
 operating conditions 17-10
 operation, flow of viii
 operators for user-defined computation 9-24
 Option 13-43
 options ii
 OR 6-30, 6-33, 10-14, 10-70, 10-74
 OR trigger 2-11, 6-30
 OS 13-19
 Others 13-41, 13-44
 OUT 6-34, 10-8, 10-13
 output terminal (trigger) 14-3
 over compensated 3-10
 Overview 13-43, 16-11
 Overview window 13-43
 Own 10-55

P

P-P Comp 12-21
 page description language 11-9, 11-13
 panel keys 1-3
 Panel Update 13-31
 paper feed knob 11-2
 parallel pattern 10-25
 parallel pattern search 2-27, 10-29
 ParallelPattern 10-20
 Parameter 10-10, 10-72
 Part 10-67

partition 12-13
 Pass-Thru 9-15
 passive probe iv
 Password 13-10, 13-17
 Pattern 6-21
 Pattern Format 10-80
 pattern trigger 2-10, 6-21
 PC card 12-5
 PC card slot 1-1
 PC card test 16-10
 PC environment 13-19
 peak computation 2-24, 9-28
 periodic mail 13-14
 periodic transmission 13-36
 permitted supply voltage frequency range 3-5
 permitted supply voltage range 3-5
 Persist 8-7
 persistent mode 8-7
 PH App-19
 PHASE 1-4
 phase angle 2-19
 phase correction 3-10
 phase correction of the probe 3-10
 phase function App-19
 phase shift 9-18
 pointer 4-9
 Polarity 6-37, 6-38
 Pos 6-38
 POSITION 1-4
 Position 2-2, 5-4
 post-data 2-13
 post-trigger 2-13
 power consumption, maximum 3-5
 power cord ii
 power fuse 17-10
 power spectrum App-23
 power spectrum computation 2-22, 9-13
 power spectrum density App-23
 power switch, turning ON/OFF 3-6
 pre-data 2-13
 pre-trigger 2-13
 prefix unit 4-8
 preparations for using the Web server function 13-21
 PRESET 1-3
 preset 2-34, 5-13
 Preview 11-4, 11-5
 Previous 10-81
 primary 13-6
 PRINT 1-5
 print format 11-5
 Print Range 11-5
 printer cover 11-2
 printer name 13-11
 printer roll paper iv, 11-1
 printer test 16-10
 priority 10-84
 Probe iii, 3-7, 5-8, 5-12
 probe attenuation 2-3
 PROBE POWER 3-8
 probe power supply terminal 1-1
 properties 12-19
 Proximal 10-49, 10-53
 PS 9-12
 Pulse 8-5
 pulse interpolation 2-18
 pulse width 10-25
 pulse width computation App-22
 pulse width search 2-28, 10-30

Index

Pulse<Time 2-10, 6-28, 10-30
Pulse>Time 2-10, 6-28, 10-30
purple characters 4-1

Q

Quad 8-3
Quit 11-4
Quit & To TopMenu 10-68

R

R 12-45
R/W 12-45
Range 12-21, 13-33
range saved 12-26
range that can be analyzed 10-84
rated supply voltage 3-5
rated supply voltage frequency 3-5
read direction of bits 10-84
realtime sampling mode 2-6
rear panel 1-1
Recall 12-2
recalled setup data 12-2
Record Length 2-15, 7-2
Rect 9-14
rectangular 2-22
Redraw 10-68
Ref 10-40
Reference 10-47
reference angle 2-29
reference cursor 2-29
reference point 10-52, 10-84
reference waveform 10-52, 10-70
release arm 11-2
Remote Control 13-21
Rename 12-50
Repetitive 7-4
repetitive sampling 7-4
repetitive sampling mode 2-6
replacement parts, recommended 16-12
Reset 12-45
Resolution 11-8, 11-9, 11-12, 11-13
response 13-36
response area 13-36
response display area 13-36
Result Window 10-16
retrieve interval 13-33
RGB 14-5, 15-4
Right 10-7
RJ-45 connector 13-1
roll mode display 2-7
roll paper iv, 11-1
roller 11-2
rubber feet 3-4
Running 1-6
Running Post 1-6
Running Pre 1-6
Running Waiting for Trigger 1-6

S

SECAM 6-39
safety standards 17-11
sample rate 2-6
sampled data 2-5

sampling mode 2-6, 2-15
sampling theorem 2-6
Save to File 6-45, 10-71
scale 2-20
Scale Value 1-6, 2-20, 8-17
scaling 2-4, 9-4
scaling (computed waveform) 2-21
screen 1-6
screen image 12-42
screen image data, attachment of 13-13
screen image, printing of 2-35
screen, splitting of 2-18
SCSI 1-1, 12-7
SCSI ID 12-8
SCSI test 16-10
Sdv 10-59
SEARCH 1-3
search & zoom 2-26, 10-15
search condition (SPI) 10-87
search logic 10-9, 10-14
search method 10-9, 10-14
Search Mode 10-5, 10-10
search parameter 10-13
search range 10-9, 10-14
search result 10-9
Search Setup 10-5, 10-10
search start point 10-26, 10-28, 10-30, 10-31
search type 10-87
search zone 10-8
Searched Pattern 10-17
second order derivative App-20
second order integration App-21
security settings 13-24
Select 5-11, 5-17, 11-6
Select Param 10-11
Select Record 10-1
Select Zone 10-6
self-test 16-8
Send 13-36
Send Mail 6-45, 10-71
sensitivity 2-2, 9-4
sequential store 2-17, 7-10
serial pattern 10-25
serial pattern search 2-26, 10-26
SerialPattern 10-18
Set 12-45
settings, initialization of 2-34
SETUP 1-4
setup data, initialization of 2-34
setup data list 1-8
setup data, saving of 12-18
setup data, storage destination of 12-2
setup dialog box 4-2
setup error 16-5
shift (phase) 2-21
shift, amount of 9-18
SHIFT+panel key vii
Show Map 10-2
Show Result 10-56
signal input section 17-1
signal input terminal 1-1, 3-7
SIMPLE 1-4
simple averaging 2-16, 2-23, 7-7, 9-27
simple trigger 2-8
Sine 8-5
sine interpolation 2-18
Single 8-3, 10-71
single (N) mode 2-13, 6-2

- single mode 2-12, 6-2
 Single(N) 7-10
 skew correction 4-22
 Slope 2-8, 6-10
 smoothing 9-5, 9-16
 SMTP client 13-12
 SMTP Time Out 13-44, 13-45
 Snap 12-28
 SNAP SHOT 1-5
 snapshot 2-20, 8-15
 SNTP 13-41, 13-42
 Soft Key 16-9
 soft key test 16-10
 soft keys 1-1
 Source 6-9
 spare parts iv
 specified record length 2-15
 Speed 10-24, 10-32
 SPI 2-28
 SPI signal analysis 2-28
 SPI signal analysis and search function 10-82
 standard operating conditions 17-10
 Start Point 9-20, 10-21, 10-22
 Start Record 10-1
 START/STOP 1-5, 7-1
 statistical processing 2-30, 10-59
 Statistics 10-54, 13-34
 status 6-17
 status determination pattern 10-28
 status messages 16-2
 status pattern 6-23
 Stopped 1-6
 storage 17-7
 storage altitude 17-10
 storage conditions 17-10
 storage medium 2-35, 12-18
 Store as 10-68
 Store Detail 12-1
 Store/Recall 12-1
 stored items 12-2
 STP 13-1
 string, entry of 4-4
 Subnet Mask 13-5
 SUFFIX ii
 symbols v, vii
 synchronization signal 6-23
 system configuration 2-1
 system error 16-7
- T**
- T1<Pulse<T2 2-10, 6-28, 10-30
 Target CH 4-21
 TCP/IP Setup 13-3
 temporary storage 4-5
 Test Item 16-8
 test mail, sending of 13-14
 text, entry of 4-4
 thermal-sensitive paper 11-1
 Thr Lower 9-7
 Thr Upper 9-7
 Threshold 9-22
 threshold level 5-19
 threshold level for binary computation 9-7, 9-27
 Thumbnail 12-38, 12-40, 12-42
 Time 10-22, 10-52
 time axis 2-5
 time axis scale 2-5
 time axis setting, sample rate, and record length, App-1
 Time Base 2-5, 5-20
 time base 5-21
 time difference 13-42
 Time Difference From GMT 13-41
 Time Difference from GMT 3-14
 Time Out 2-10, 6-28, 10-30, 13-10, 13-17
 Time Range 8-13, 10-12, 10-48, 10-62, 10-69, 10-73, 11-3
 time stamp 10-3
 time window 2-22, 9-14
 TIME/DIV 5-22
 TIME/DIV knob 1-3
 timeout time 2-12, 13-45
 To EditMenu 10-66
 transfer function App-24
 Translucent 2-20, 8-20
 transmission command entry area 13-36
 transmission interval 13-14, 13-36
 transmission time 13-13
 trend display 13-33
 Triad 8-3
 TRIG GATE IN 14-1
 TRIG OUT 14-3
 TRIG'D indicator 1-4
 trigger 2-8
 trigger condition 6-23
 trigger coupling 2-13, 6-11, 6-17
 trigger delay 2-13, 6-5
 Trigger Gate 2-14, 6-46, 6-47
 trigger gate input 14-1
 trigger gate input terminal 1-1
 trigger hold off 2-14
 trigger hysteresis 2-14
 trigger level 2-8, 6-11, 6-17
 trigger level mark 1-6
 trigger mode 2-12
 trigger output 14-3
 trigger output terminal 1-1
 trigger point 2-13
 Trigger Position 2-13, 6-4, 10-78
 trigger section 17-2
 trigger slope 2-8, 6-11
 trigger source 2-8, 6-11
 trigger status 6-23
 troubleshooting 16-1
 TV 6-36
 TV trigger 2-11, 6-36
 Type 5-11, 5-18, 10-80

U

- under compensated 3-10
 Update 13-34
 update mode 2-7
 Upper 10-7, 10-12
 USB 11-6
 USB keyboard language 15-2
 USB connector 1-1
 USB connector for PC connection 1-1
 USB connector for peripheral connection 1-1
 USB keyboard 2-34, 4-6
 USB keyboard, key assignments of App-28
 USB mouse 2-34, 4-9
 USB PERIPHERAL connector 4-6
 USB printer 11-8
 User 8-3, 9-19

Index

User Account 13-16, 13-17
User Define Setup 9-19
User Name 13-16, 13-17
user-defined computation 2-23
Utility 12-41
UTP 13-1

V

V/DIV 5-2
V/DIV knob 1-3
valid data range 2-2
values, entry of 4-3
Variable 5-2
variable T 9-25
Vertical 10-35
vertical cursor 2-29, 10-41
vertical position 2-2, 5-4
vertical position mark 1-6
vertical sensitivity 2-2
VGA 14-5
VIDEO OUT 14-5
video signal 6-36
video signal output 14-5
video signal output connector 1-1

W

warm-up 3-6, 17-10
Waveform 12-20
waveform acquisition count 10-71
waveform computation 2-21
waveform inversion 9-9
waveform label 1-6, 2-20, 5-19, 8-19
waveform mapping 2-18, 8-3
waveform parameter search 2-25
waveforms, number of 10-3
Web server 2-33, 13-18
Web server, requirements 13-19
WebDAV 13-47
Weight 7-7, 17-10
weighted moving average 9-5
Whole 10-67
Width 6-25, 6-33, 6-35, 10-22
width trigger 2-10, 6-25
Width Type 6-25
Window 6-33, 6-35
window trigger 2-11, 6-33
withstanding voltage 17-10

X

X 6-17
X Axis 8-12
X Trace 8-13
X-axis mode 8-14
X-Y 1-4
X-Y waveform display 2-19
X-Y waveform display frame 1-8

Y

Y Trace 8-13
Year 3-14

Z

Z1 Mag 8-9
Zip disk 12-4
Zone 10-5, 10-66
zone search 2-25
ZOOM 1-3
zoom 2-19, 8-11
zoom box 1-7
zoom position 1-7, 8-11
zoom range 1-7
zoom ratio 8-11
zoom waveform display frame 1-7